



Operation & Maintenance Manual

VER Vertical Unit Ventilator with Integral Energy Recovery



IMPORTANT: Read and save this manual for future reference.
This manual is to be left with the equipment owner

Table of Contents

INTRODUCTION

About the VER	2
Nomenclature for VER	2

TYPICAL UNIT LAYOUT

Model VER 1800 (ducted)	3
-------------------------------	---

OPERATION

Sequence of Operation	4
Hot Water Circuit	5
Refrigeration Circuit	6
Electrical Circuit	7
Dampers	7
Optional 100% Economizer	7
Optional Powered Exhaust	7
Filtration	7

MAINTENANCE

Servicing the Unit	8
Maintenance Schedule	8
Changing the Filters	9
Waterside Component Maintenance	9
Cleaning the Evaporator Coil	10
Motors	10
Cleaning the Energy Recovery Wheel	10

TROUBLESHOOTING

Basic Troubleshooting Guidelines	11
--	----

REPLACEMENT PARTS

Limited Warranty	12
Part Sales	12

INTRODUCTION

ABOUT THE ENERGY RECOVERY UNIT VENTILATOR

The Temspec integrated energy recovery unit ventilator was designed as a means for providing energy efficient heating, cooling and ventilation to the classroom. Our goal is to help create an enhanced learning environment by focusing on the following points when designing our equipment:

- TEMPERATURE & HUMIDITY CONTROL
- AIR DISTRIBUTION
- SOUND ATTENUATION
- ENERGY EFFICIENCY

By introducing the VER into the classroom, superior control can be obtained for each room. Because of the unit's ducting capabilities, an even distribution of air can be achieved throughout the room. The VER is constructed with heavy gauge metal and sound absorbing insulation for optimal sound attenuation.

By applying sound engineering principles and through continuous testing, the highest quality of performance is obtained in the unit ventilator.

NOMENCLATURE FOR UNIT VENTILATORS INTEGRAL ENERGY RECOVERY

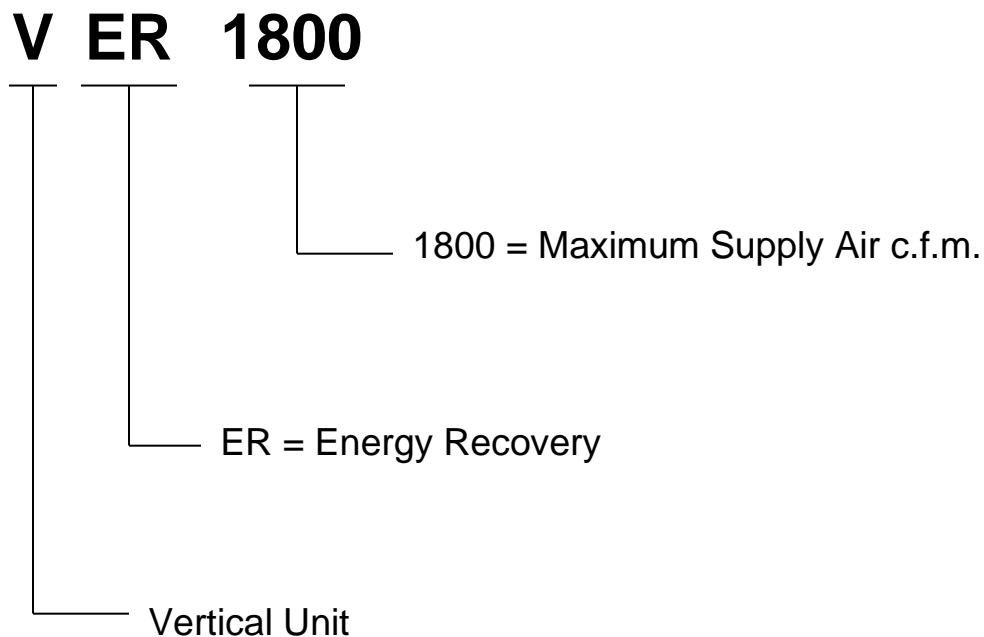

TYPICAL LAYOUT

Models VER 1800 – HW / DX Split (ducted configuration)

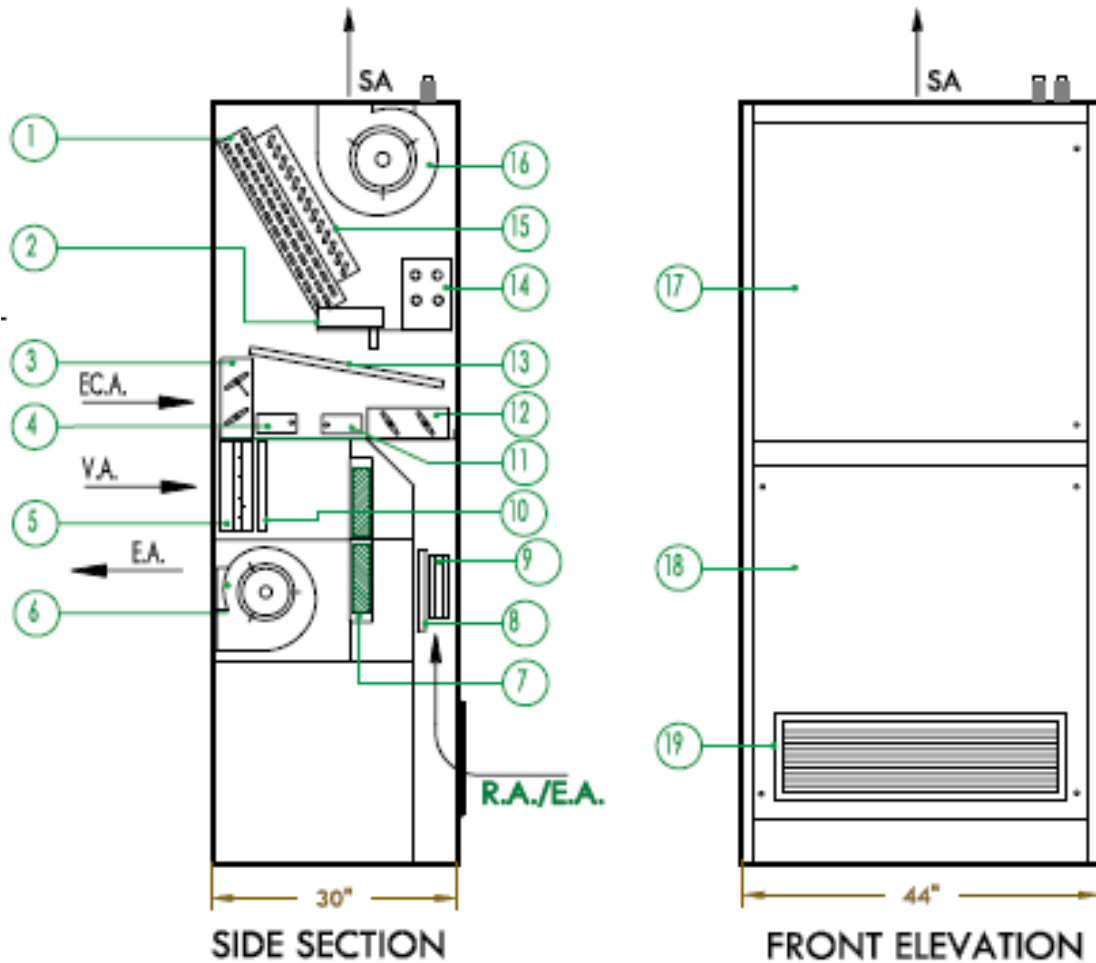

SA = Supply Air
RA = Return Air

VA = Ventilation Air
EA = Exhaust Air

ECA = Economizer Air

ITEM NO.	DESCRIPTION	ITEM NO.	DESCRIPTION	ITEM NO.	DESCRIPTION
1.	Evaporator Coil	8.	ERV Exhaust Filter	15.	Hot Water Coil
2.	Drain Pan	9.	Powered Exhaust Damper and Actuator	16.	Supply Air Fan
3.	100% Economizer OA Damper	10.	ERV O.A. Filter	17.	LH Hinged Access Panel
4.	Modulating damper actuator.	11.	RA Actuator	18.	Removable Access Panel
5.	ERV Damper with Actuator.	12.	RA Damper	19.	Heavy Duty RA Grille
6.	ERV Exhaust Fan	13.	Mixed Air Filters		
7.	ERV Enthalpy Wheel	14.	Electrical Box/Controls Enclosure		

NOTE: The component arrangement shown above may vary slightly from that in the unit supplied.

OPERATION

Typical Modes of Operation

The following is a control strategy table for a VER 1800 with integral ERW, powered exhaust and W7212 Honeywell Economizer Module. The UV has one stage of DX cooling and modulating hydronic heat.

	Occupied Heat	Unoccupied Heat	Occupied (neutral) No mech. Cooling or Heating	Unoccupied (neutral) No mech. Cooling or Heating	Occupied Economizer	Unoccupied Economizer	Occupied Cool	Unoccupied Cool
Indoor Fan(s) 24 VAC – ON / OFF	ON – 1 minute start delay	ON – 1 minute start delay	ON – 1 minute start delay	OFF	ON – 1 minute start delay	ON – 1 minute start delay	ON – 1 minute start delay	ON – 1 minute start delay
Cooling signal 24 VAC – ON / OFF	OFF	OFF	OFF	OFF	OFF	OFF	ON	ON
Heating Valve 0 to 10 VDC – analog	ON	ON	OFF	OFF	OFF	OFF	OFF	OFF
Return Air damper (RAD) 24 VAC – ON / OFF	OPENED to the RA/VA balanced position	OPENED to the RA/VA balanced position	OPENED to the RA/VA balanced position	OPENED to the RA/VA balanced position	OFF	OFF	OPENED to the RA/VA balanced position	OPENED to the RA/VA balanced position
Outdoor Air damper (ECOND) 0 to 10 VDC – analog	CLOSED	CLOSED	CLOSED	CLOSED	Modulates between CLOSED and 100% to maintained SA temp. between 50° & 55 ° F	Modulates between CLOSED and 100% to maintained SA temp. between 50° & 55 ° F	CLOSED	CLOSED
ERW + VA Damper (VAD) 24 VAC – ON / OFF	ON	OFF	ON	OFF	OFF	OFF	ON	OFF
ERW Preheat Electric Coil (OPTIONAL) 24 VAC – ON / OFF	ON – 1 minute start delay if OA less than X °F (adjustable)	OFF	ON – 1 minute start delay if OA less than X °F (adjustable)	OFF	OFF	OFF	ON – 1 minute start delay if OA less than 0°F (adjustable)	OFF
Exhaust Fan low speed 24 VAC – ON / OFF	ON – 1 minute start delay	OFF	ON – 1 minute start delay	OFF	OFF	OFF	ON – 1 minute start delay	OFF
Exhaust Fan HIGH speed 24 VAC – ON / OFF	OFF	OFF	OFF	OFF	ON – 1 minute start delay	ON – 1 minute start delay	OFF	OFF
Exhaust Damper (EXAD) 24 VAC – ON / OFF	OFF	OFF	OFF	OFF	ON	ON	OFF	OFF

NOTE: The Economizer, based on an increased requirement for cooling can modulate the Outdoor Damper in full-open position. If the outdoor air temperature (measured by the mixed air sensor) drops to 45°F, the Economizer fully closes the damper to protect from freezing the hot or chilled water coils. Control returns to normal once the mixed air temperature rises to 48°F.

Freeze Protection

For units with a steam or hot water coil, some type of freeze protection is usually implemented. This can be either low limit temperature control (manual or auto reset) or by using a supply air sensor and programming from the controller. When a mixed air temperature is determined to be too low, the outdoor air damper will close, and the control valve will fully open. In some cases, the fan will also shut down until the temperature returns to normal levels.

Hot Water Circuit

The following is a typical hot water piping schematic for the VER 1800. Please refer to the shop drawings for a more specific layout.

Hot Water with 2-Way Control Valve

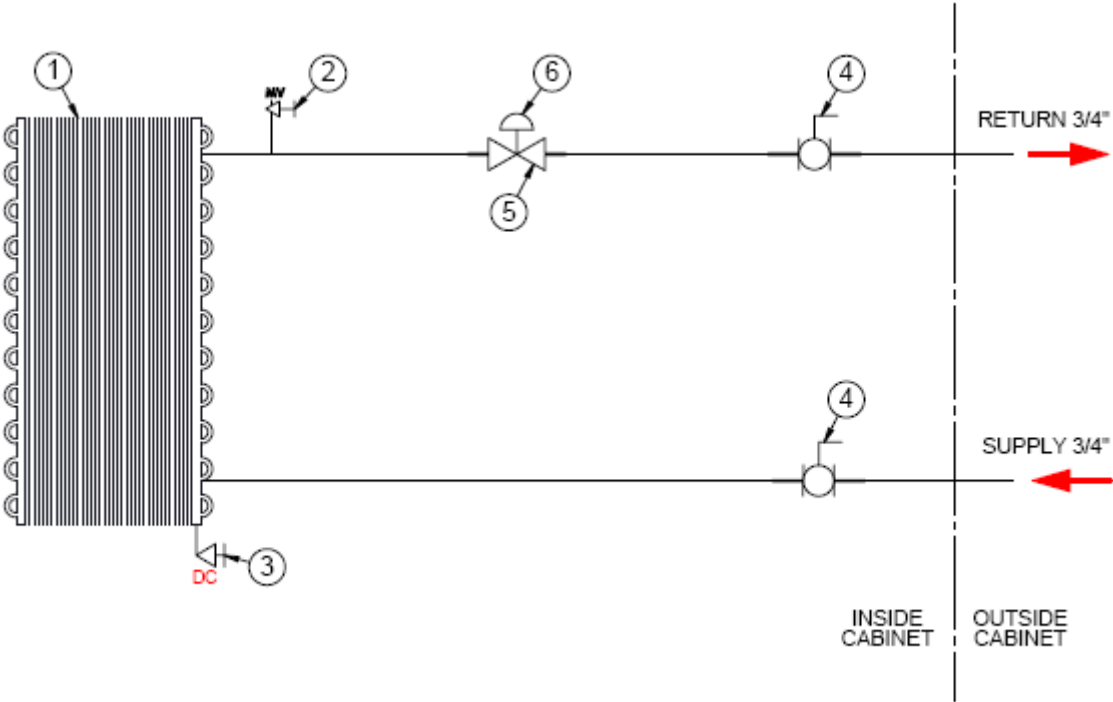

ITEM NO.	QTY	DESCRIPTION	ITEM NO.	QTY	DESCRIPTION
1.	1	Hot Water Coil	5.	1	Valve, 2-Way, Modulating
2.	1	Manual Air Vent	6.	1	Actuator - Modulating
3.	1	Drain Cock			
4.	1	Ball Valve – Memory Stop			

Warning: City water is very corrosive to brass Components. Provide water treatment as soon as the system is charged to avoid premature leaks and/ or failure of internal components.

DX Refrigeration Circuit

The following is a typical DX Split piping schematic. Please refer to the shop drawings for a more specific layout.

VER-1800D - SPLIT - 1000/1200 CFM

PRESSURE TESTED AT 450 PSIG

BRAZED UNDER NITROGEN

REFRIGERANT: R410A

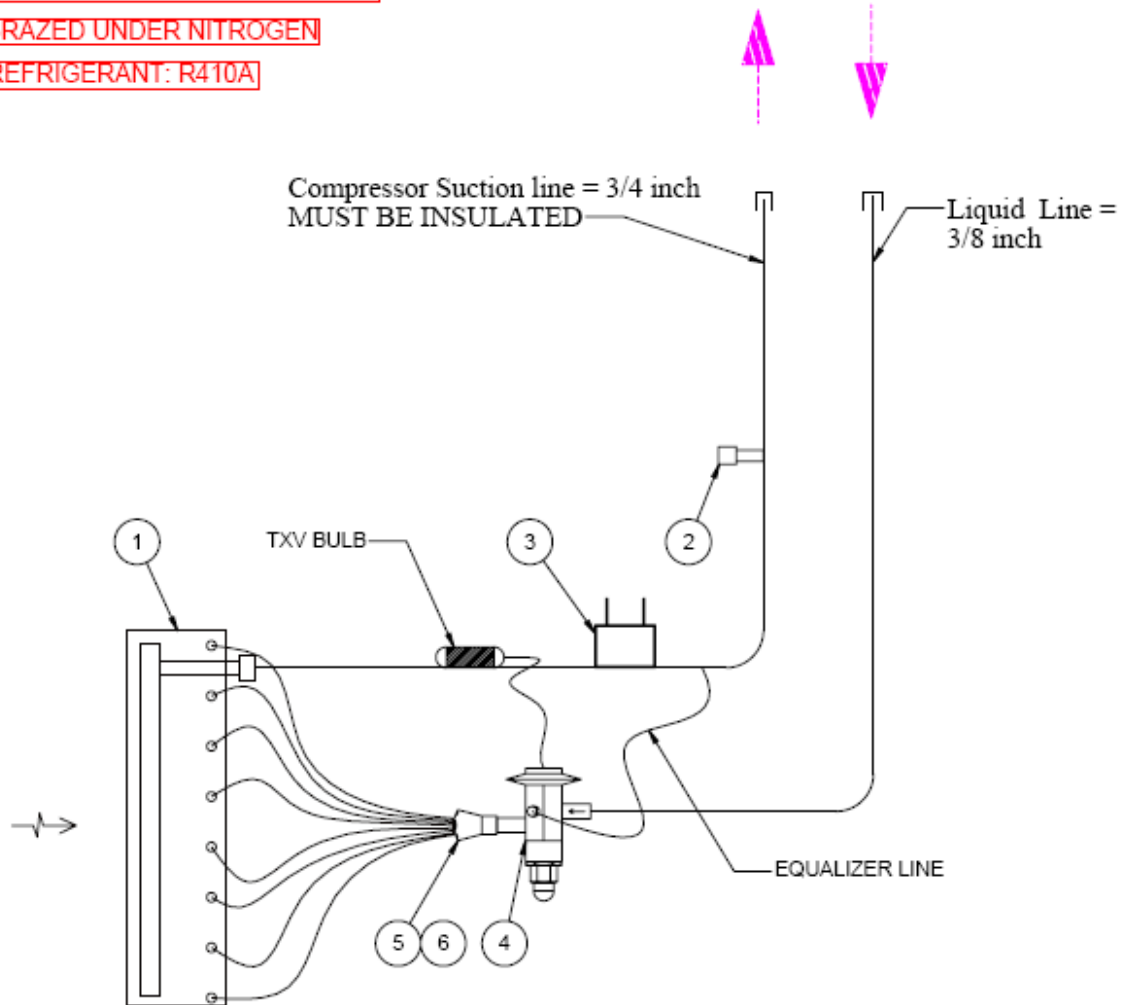

ITEM NO.	QTY	DESCRIPTION
1.	1	Coil – DX – R410A
2.	1	Valve – Access – With Core – 600psi
3.	1	Controller – Anti-Ice
4.	1	Valve – TX-R410A
5.	1	Distributor
6.	1	Nozzle – Size J2

Electrical Circuit

The electrical circuit in the VER 1800 is dependent on the controller and sequence that is being utilized. The unit can be supplied with a 115V, 208V, 277V or 460V power supply. The unit is equipped with an unfused service disconnect. A copy of the electrical schematic can be found folded in a pouch inside of unit ventilator located on the electrical enclosure or supply air fan housing.

Dampers

All the outdoor air damper assemblies have airfoil section extruded aluminum blades with flexible seal blade tips, jamb seals and spring return damper actuators. The damper actuator manufacturer can vary. Please refer to the wiring schematic for the damper actuator model type and control.

100% Economizer (optional)

100% economizer is an option feature on the energy recovery unit ventilator. This module includes a modulating spring return damper actuator and aluminum damper assembly and associated controls.

100% Powered Exhaust (optional)

Internal powered exhaust is an optional feature that may be provided with the VER series. This feature comes with a spring return actuated aluminum damper, direct drive fan and ECM motor. It shall operate in tandem with the economizer damper to be able to provide up to 100 % power exhaust

Filtration

Typically, 1" or 2" disposable filters are provided in the unit. Please refer to the "shop drawings" for specific details on filter construction and thickness for your unit. Below are the sizes and quantity for the typical base unit and additional filters for optional modules.

<u>Location</u>	<u>Filter Size</u>	<u>Quantity per Unit</u>
Mixed Air	20" x 25" nominal	2
Energy Recovery Module	12" x 20" nominal	2

MAINTENANCE

Servicing the Unit

Maintenance to the unit is accomplished by removing the front access panels. Typically, the panels are secured by heavy duty Phillips (star or cross shape) head screws. When removing the access panel, loosen but do not remove the screws. Carefully store the panel in a place where it will not get damaged. Use caution as some access panels are heavy.

CAUTION: Disconnect power at the remote circuit breaker before servicing the unit.

The unit comes fitted with a “fan kill switch” that de-energizes the supply air fan(s) when the filter access panel is removed / opened. This will only disconnect the power to the supply air fans. Be sure to disconnect ALL power by turning the remote circuit breaker to the off position.

To access the ERV section, you must remove secondary panels located directly behind the return air access panel.

Maintenance Schedule

Interior and exterior environmental conditions will influence the required frequency of coil cleaning and filter change operations. The following is a typical maintenance schedule for a classroom unit ventilator.

- | | |
|-------------------------|--|
| Initial Start-Up | <ul style="list-style-type: none"> • Change out construction filters. • Verify that air paths are free of construction debris and that fans turn freely • Verify dampers and ERV operation. |
| Every 3 months | <ul style="list-style-type: none"> • Change filters |
| Every 6 months | <ul style="list-style-type: none"> • Visually inspect the condition of ERV desiccant wheel, clean if necessary. |
| Every 12 months | <ul style="list-style-type: none"> • Vacuum out the cooling coil drain pan • Clean strainer in the hydronic circuit (if applicable) |
| Every 24 months | <ul style="list-style-type: none"> • Clean cooling coil • Vacuum any loose debris from unit's interior return air section • Inspect dampers to ensure that there is a proper seal |

Changing the Filters

The outdoor and indoor conditions of your area will determine the frequency of filter changes. Temspec recommends that the filters be changed every 3 months as a rule-of-thumb. Note that dirty filters adversely affect the overall performance of the unit.

To change the mixed air and ERV outdoor air (OA) filters, open / remove the top access panel by loosening the Phillips head screws, unclip the two mixed air filters and remove. If the unit is equipped with an ERV module you can remove and replace the ERV OA filters which is located below the mixed air filters near the back-right side of the unit.

Be sure to note the airflow direction that is marked on the filter(s).

To change the ERV exhaust filter remove the return air access panel by loosening the Philips head screws, unclip the ERV exhaust filter located on the on the ERV access panel and replace filter noting the airflow direction on the filter.

Replace all access panels and ensure fasteners are securely fastened.

Waterside Component Maintenance

The following are the recommended steps for performing maintenance on the Hydronic portion of the unit.

CAUTION: Disconnect power at the remote circuit breaker before servicing the unit.

- Clean strainer, check and clean regularly. See the maintenance schedule for suggested frequency.

Cleaning the Cooling and Heating Coils

CAUTION: Disconnect power before servicing the unit.

WARNING: Do NOT use condenser coil cleaning compounds on the cooling or heating coils.

To clean the evaporator coil, purchase a suitable evaporator coil cleaning solution such as those offered by NU-CALGON. Follow the manufacturer's instructions for use.

Note: Chlorine based or anti-fungal "pucks" or "socks" are acceptable when **placed in the evaporator drain pan**. Be sure to vacuum the drain pan after the cleaning process is complete and prior to adding the anti-fungal component.

WARNING: Do NOT use chlorine-based cleaners or anti-fungal treatments on the aluminum fins of any coil.

Motors

Temspec provides motors that are permanently lubricated. No maintenance is required.

Cleaning the Energy Recovery Wheel

CAUTION: Disconnect power before servicing the unit.

Temspec recommends that the ERV desiccant wheel be cleaned with a vacuum periodically and that the use of a cleanser is only required when the necessary. When cleaning the wheel with a vacuum take care not to damage the wheel's polymer material.

WARNING: Do NOT use ACID based solutions, AROMATIC solvents, STEAM OR WATER with temperatures GREATER than 170°F.

The clean desiccant coated polymer energy recovery wheel you will require a non-acid based (evaporator) coil cleanser or alkaline detergent.

First you must gain access to the energy recovery wheel by removing the return air and ERV access panel by loosening the required fasteners. Once this is completed follow the recommended steps of the wheel manufacturer AirXchange listed below.

- Remove wheel from Unit Ventilator
- Remove the wheel from the cassette
- Remove loose accumulated dirt by brushing the wheel face
- Wash the wheel with a non-acid based (evaporator) coil cleanser or alkaline detergent solution. (The wheel manufacturer suggests cleaners such as KMP Acti-Clean in a 5% solution works well)
- If the wheel is extremely dirty it may be required to soak overnight to remove all contaminants.
- Once soaking completed, rinse the solution from the wheel until the water comes clear.
- Allow excess water to drain and re-install cassette.

PLEASE NOTE: There may be some staining to the desiccant however this will not adversely affect the performance.

For more information please see the ERV manufacturers' website;

<http://www.airxchange.com/resource-center-technical-notes.htm>

ERV Model: ERC 2108 with 2" cassette

TROUBLESHOOTING

Basic Trouble Shooting Guidelines

Problem

- Supply fan not running

Action Required

- Verify that the disconnect is in the “on” position
 - Verify that door micro-switch “kill switch” is completely depressed and operating correctly
 - Verify that thermostat / controller is not in unoccupied mode (night set-back)
 - Check manual reset controls (e.g. electric heat, high refrigerant pressure controls and low limit temperature control) and ensure that they have not been tripped.
 - Check the fan relay to observe if it is energizing and de-energizing properly
 - Check that the 24V transformer is working properly
 - Ensure that the wire connections are secured properly
-
- Compressor short cycles
- Ensure that there are no obstructions which would cause the unit to cut-out on high head pressure
 - Check refrigerant level. If the level is too low, the unit will cut-out on low pressure.

REPLACEMENT PARTS

Limited Warranty

TEMSPEC INCORPORATED warrants the equipment from factory defects in material or workmanship for a period of one year.

For this warranty to be valid, the unit(s) must be installed and maintained in accordance with the manufacturer's printed instructions. It does not cover parts damaged by vandalism, improper installation, maintenance or abuse.

Should any replacement parts be required within the warranty period, they will be supplied at no charge, freight prepaid to the jobsite. The cost of labor or incidental expenses incurred in the repair or replacement of parts does not form part of this warranty.

The warranty period commences from the date of shipment, except when otherwise agreed at the point of sale (see specific warranty terms and conditions for details).

Parts Sales

Contact the factory at: 1-888-TEMSPEC or (905) 670-3595

sales@temspeg.com

Ask for 'parts sales'

Be sure to provide the unit serial number, which is located on the metalized CSA label, on the fan housing, inside the units.