



Operation & Maintenance Manual

VGB & HGB Series Classroom Fan Coil Units



IMPORTANT: Read and save this manual for future reference.
This manual is to be left with the equipment owner

Table of Contents

INTRODUCTION

| | |
|---|---|
| About the Classroom Fan Coil unit | 2 |
| Nomenclature for Classroom Fan Coil units | 2 |

TYPICAL UNIT LAYOUT

| | |
|--------------------------------|---|
| Model VGB 1600 DDX / DCW | 3 |
| Model VGB 1600 BCW / BDX | 4 |
| Model HGB 1600 | 5 |

OPERATION

| | |
|--|----|
| Control Strategy with Chilled Water Cooling, Electric or Hot Water Heating | 6 |
| Control Strategy with DX Cooling, Electric or Hot Water Heating | 7 |
| Chilled Water Circuit | 8 |
| Refrigeration Circuit | 9 |
| Electrical Circuit | 10 |
| Damper | 10 |
| Filtration | 10 |

MAINTENANCE

| | |
|-------------------------------------|----|
| Servicing the Unit | 11 |
| Maintenance Schedule | 11 |
| Changing the Filters..... | 12 |
| Cleaning the Evaporator Coils | 12 |
| Motors | 12 |

TROUBLESHOOTING

| | |
|---------------------------------------|----|
| Basic Troubleshooting Guidelines..... | 13 |
|---------------------------------------|----|

REPLACEMENT PARTS

| | |
|------------------------|----|
| Limited Warranty | 14 |
| Part Sales | 14 |

INTRODUCTION

ABOUT THE CLASSROOM FAN COIL UNIT

The Temspec VGB/HGB classroom fan coil unit is designed as means for providing cooling, heating and ventilation to the classroom. Our goal is to help create an enhanced learning environment by focusing on the following points when designing our equipment:

- COOLING, HEATING, HUMIDITY AND VENTILATION CONTROL
- AIR DISTRIBUTION
- SOUND ATTENUATION

By installing the VGB/HGB fan coil unit into the classroom, superior control can be obtained for each room. Because the unit can be ducted, an even distribution of air can be achieved throughout the room. The classroom fan coil unit is constructed with heavy gauge metal and sound absorbing insulation for optimal sound attenuation.

By applying sound engineering principles and thorough testing, we ensure the highest quality of performance in our unit ventilators.

NOMENCLATURE FOR CLASSROOM FAN COIL UNITS

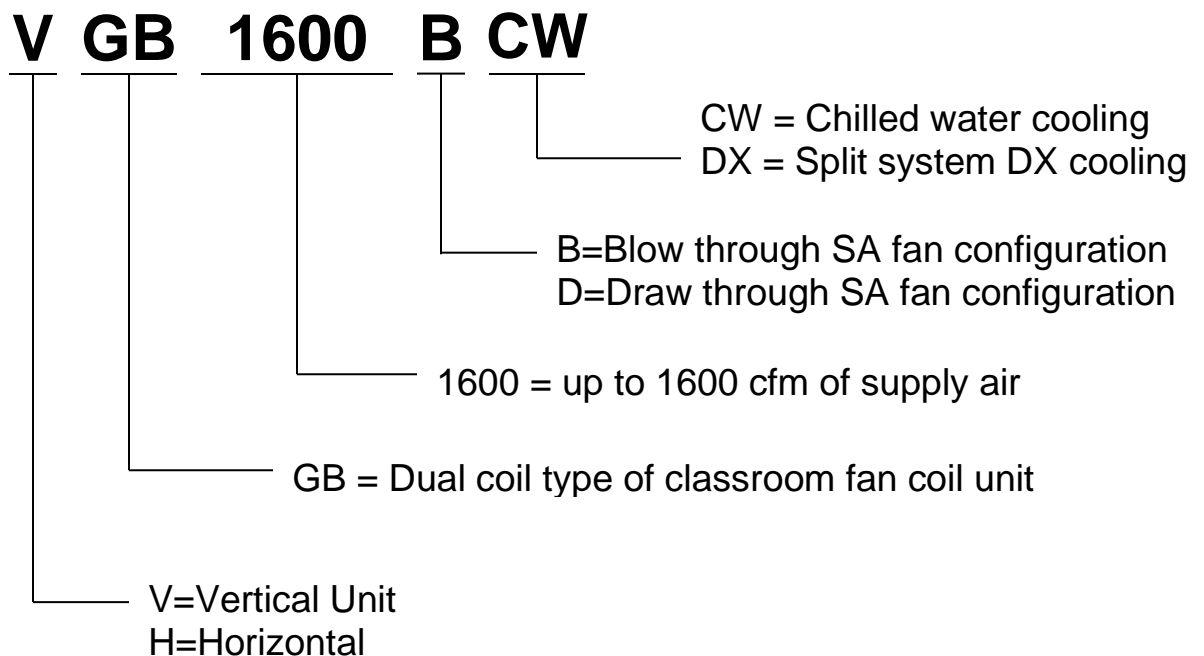

TYPICAL LAYOUT

Model VGB 1600 DDX / DCW (Upflow, Ducted Configuration)

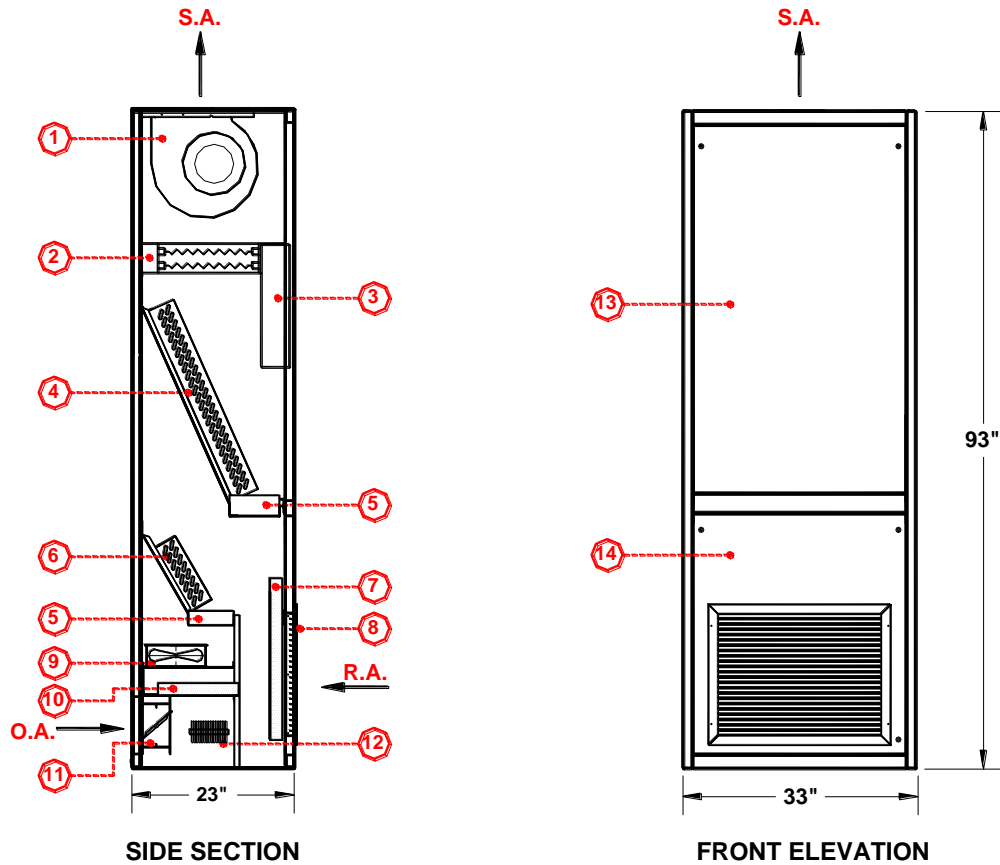

S.A. Supply Air **O.A.** Outdoor Air **R.A.** Return Air

- | | |
|--|--|
| 1. Supply air fan. | 8. Heavy duty return air grille. |
| 2. Optional electric coil. | 9. Outdoor air fan. |
| 3. Control / electrical enclosure. | 10. Outdoor air filter. |
| 4. Primary coil (DX or chilled water). | 11. Outdoor air damper. |
| 5. Drain pan. | 12. Optional electric freeze protection. |
| 6. Outdoor air coil (DX or chilled water). | 13. Coil access panel. |
| 7. Return air filter. | 14. Return air access panel. |

NOTE: The component arrangement shown above may vary slightly from that in the unit supplied.

TYPICAL LAYOUT

Model VGB 1600 BDX / BCW (Upflow, Freeblow Configuration)

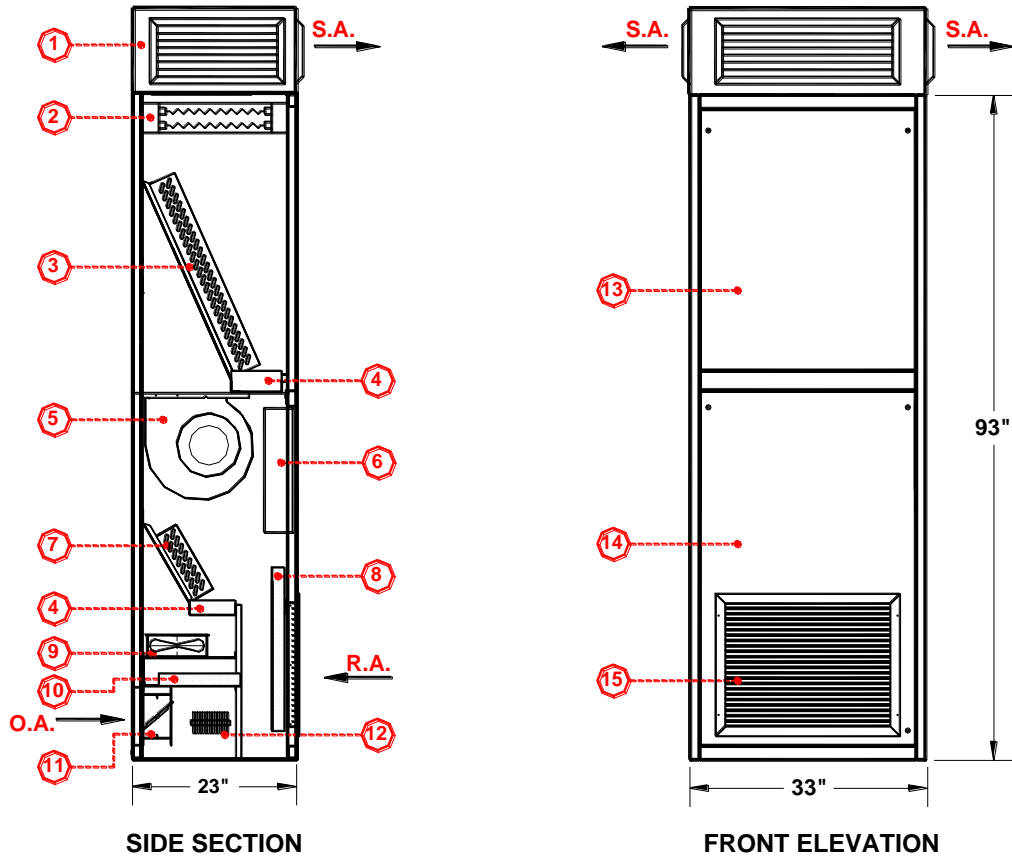

S.A. Supply Air O.A. Outdoor Air R.A. Return Air

- | | |
|---|--|
| 1. Optional top plenum with double deflection supply air grilles. | 8. Return air grille. |
| 2. Optional electric coil. | 9. Outdoor air fan. |
| 3. Primary coil (DX or chilled water). | 10. Outdoor air filter. |
| 4. Drain pan. | 11. Outdoor air damper. |
| 5. Supply air fan. | 12. Optional electric freeze protection. |
| 6. Control / electrical enclosure. | 13. Coil access panel. |
| 7. Outdoor air coil (DX or chilled water). | 14. Return air access panel. |
| | 15. Heavy duty return air grille. |

NOTE: The component arrangement shown above may vary slightly from that in the unit supplied.

TYPICAL LAYOUT

Model HGB 1600 (Horizontal, Ducted Configuration)

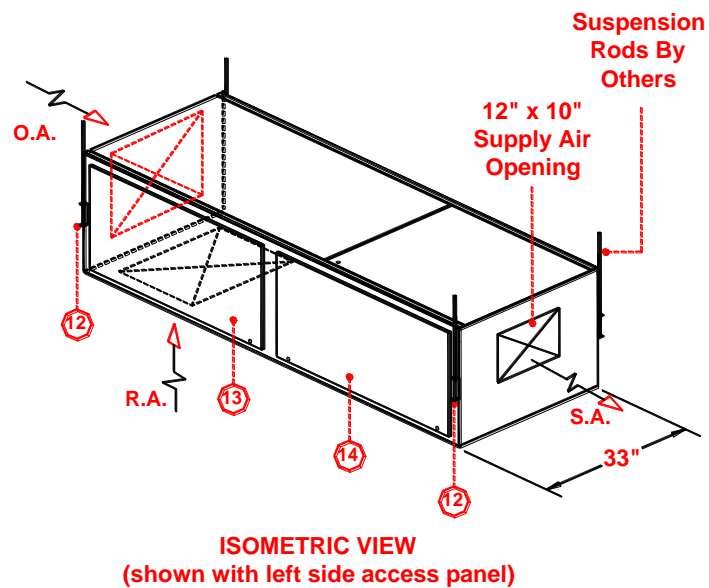
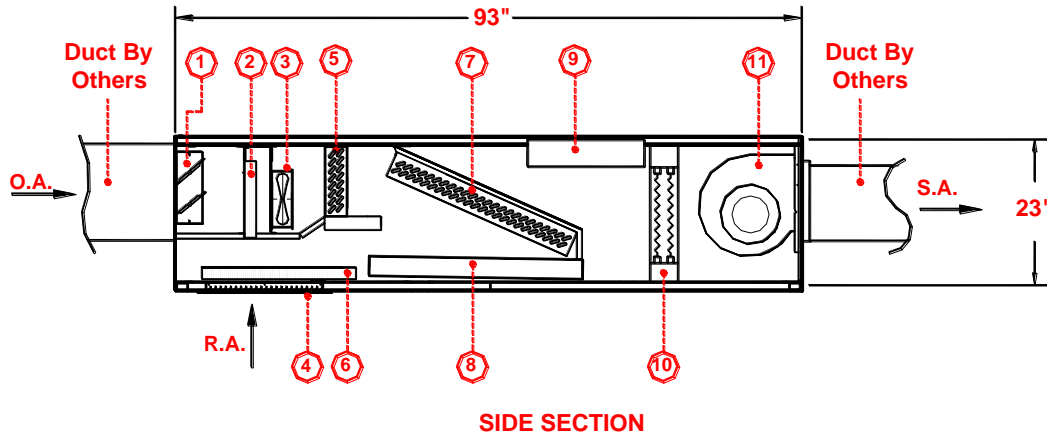

S.A. Supply Air O.A. Outdoor Air R.A. Return Air

- | | |
|---|---|
| <ol style="list-style-type: none"> 1. Outdoor air damper. 2. Outdoor air filter. 3. Outdoor air fan. 4. Heavy duty return air grille or duct collar. 5. Outdoor air chilled water or DX coil. 6. Return air filter. 7. Primary chilled water or DX coil. | <ol style="list-style-type: none"> 8. Drain pan. Drain pan is removable when option for bottom access panels is selected. 9. Electrical / control enclosure. 10. Optional Electric heater. 11. Supply air fan. 12. Mounting brackets (4 per unit). 13. Left or Right side hinged filter access panel. 14. Left or Right side hinged coil access panel. |
|---|---|

NOTE: The component arrangement shown above may vary slightly from that in the unit supplied.

OPERATION

Control Strategy

For a Temspec VGB or HGB series classroom fan coil unit with type “V” stand alone control package (thermostat model OC-3)

UNIT WITH CHILLED WATER COOLING, ELECTRIC OR HOT WATER HEATING

1. Supply Air Fan Control

The fan shall run continuously when the unit is operating in the occupied mode. The fan shall run only on a call for heating, cooling or dehumidification in the unoccupied (night setback) mode.

2. Outdoor Air Intake Fan and Damper Control

The fan shall run continuously and the damper shall be open during the occupied mode when motion is sensed. When motion ceases to be sensed after a timeout delay period, the fan shall stop and the damper close until motion is next sensed. An outdoor air temperature sensor shall close the damper and stop the fan if a temperature of 37° F or lower is measured. During unoccupied mode, the fan shall be de-energized and the damper closed.

3. Outdoor Air Cooling Coil

Pre-filtered outdoor air shall pass over the coil and be cooled and dehumidified. Chilled water to the coil shall be controlled by a two position valve. During unoccupied mode the valve shall close, as outdoor air is not induced during this period. During occupied mode, when the outdoor air damper is open, the outdoor air intake fan shall run. The valve shall open, except if the outdoor air temperature is between 37° F and 55° F db. (adjustable). Between these temperatures the fan shall run, the damper open and the valve close.

4. Outdoor Air Cooling Coil Freeze Protection (Optional)

If the outdoor air temperature is below 37° F in the occupied mode the electric preheat coil shall be energized or the hot water valve on the preheat coil shall open. The outdoor air damper shall remain open and the outdoor air fan shall run.

5. Primary Cooling Coil

Pre-filtered return air and pre-cooled outdoor air mix and the mixed air shall pass over the primary coil

to cool and further dehumidify the air. Chilled water to the coil shall be controlled by a modulating valve (0-10Vdc). During unoccupied mode only return air shall pass over the coil.

6. Heating

On a call for space heating by the thermostat, the electric coil shall pulse (by an SCR) or the hot water valve modulate (0-10Vdc) to maintain the occupied heating set point (typically 72° F). Both cooling coil control valves shall be closed. If the room temperature falls 2° F below set point and the mixed air temperature is below 60° F, the outdoor air damper shall close and the outdoor air intake fan stop until the mixed air temperature rises to 70° F.

7. Humidistat and Reheat (Optional)

A room humidistat sensor shall be included in the return air stream. The main heating coil (electric or hot water) shall be located in the reheat position relative to the primary cooling coil. The humidistat shall have a typical set point of 55% R.H. (adjustable). When the room temperature falls to the cooling set point and the humidistat set point has not been satisfied, the heating coil shall provide reheat to maintain the cooling temperature set point in the room (to avoid overcooling the space). The control valves on both the outdoor air cooling coil and primary cooling coil shall be fully open under this condition. When the humidity set point is satisfied the heating coil shall de-energize (hot water valve modulates closed) over a five minute period to allow the control valve on the primary cooling coil to resume room temperature control while avoiding temperature swings. The humidistat shall trigger dehumidification in both occupied and unoccupied modes. The reheat strategy shall be enabled during the occupied mode only.

Control Strategy

For a Temspec VGB or HGB series classroom fan coil unit with type “V” stand alone control package (thermostat model OC-3)

UNIT WITH DX COOLING, ELECTRIC OR HOT WATER HEATING

1. Supply Air Fan Control

The fan shall run continuously when the unit is operating in the occupied mode. The fan shall run only on a call for heating, cooling or dehumidification in the unoccupied (night setback) mode.

2. Outdoor Air Intake Fan and Damper Control

The fan shall run continuously and the damper shall be open during the occupied mode when motion is sensed. When motion ceases to be sensed after a timeout delay period, the fan shall stop and the damper close until motion is next sensed. During unoccupied mode, the fan shall be de-energized and the damper closed.

3. Condensing Units

The split system condensing units shall be one of the following arrangements:

- 3.1 Temspec series XXX consisting of a single cabinet with dual compressors, two-circuit condensing coil and a condensing fan.
- 3.2 Two separate condensing units as manufactured by Trane or McQuay.

The outdoor air DX coil and the primary DX coil shall be independently connected to a dedicated condensing unit. A Rawal APR valve shall be factory installed on the outdoor air condensing unit compressor to reduce the cooling capacity of the outdoor air cooling circuit during low ambient conditions, to prevent coil freezing. Installation of the refrigerant linesets and charging with R22 shall be by the installing contractor.

4. Outdoor Air Cooling Coil

Pre-filtered outdoor air shall pass over the coil and be cooled and dehumidified. During unoccupied mode the condensing unit shall be de-energized as outdoor air is not induced during this period. During occupied mode, when the outdoor air damper is open and the

outdoor air intake fan runs, the condensing unit shall operate when the O.A. temperature is above 60° F

5. Primary Cooling Coil

Pre-filtered return air and pre-cooled outdoor air mix and the mixed air shall pass over the primary evaporator coil to cool and further dehumidify the air. During unoccupied mode only return air shall pass over the coil. The cycling of the primary condensing unit shall be by the thermostat to maintain the room temperature at the cooling set point.

6. Heating

On a call for space heating by the thermostat, the electric coil shall pulse (by an SCR) or the hot water valve modulate (0-10Vdc) to maintain the occupied heating set point (typically 72° F). Both condensing units shall be de-energized. If the room temperature falls 2° F below set point and the mixed air temperature is below 60° F, the outdoor air damper shall close and the outdoor air intake fan stop until the mixed air temperature rises to 70° F.

7. Humidistat and Hot Gas Reheat (Optional)

A room humidistat shall be included in the return air stream. The hot gas reheat coil shall be located in the reheat position relative to the primary cooling coil. The humidistat shall have a typical set point of 55% R.H. (adjustable). When the room temperature falls to the cooling set point and the humidistat set point has not been satisfied, the hot gas reheat coil shall provide reheat to maintain the cooling temperature set point in the room (to avoid overcooling the space). The condensing units on both the outdoor air cooling coil and primary cooling coil shall be operating under this condition. When the humidity set point is satisfied the reheat coil solenoid valve shall close. The humidistat shall trigger dehumidification in both occupied and unoccupied modes. The reheat strategy shall be enabled during the occupied mode only.

TYPICAL PIPING PACKAGE FOR OUTDOOR AIR AND PRIMARY CHILLED WATER COILS

The following is a typical piping schematic for a classroom fan coil unit. Please refer to the “shop drawings” for a more specific layout.

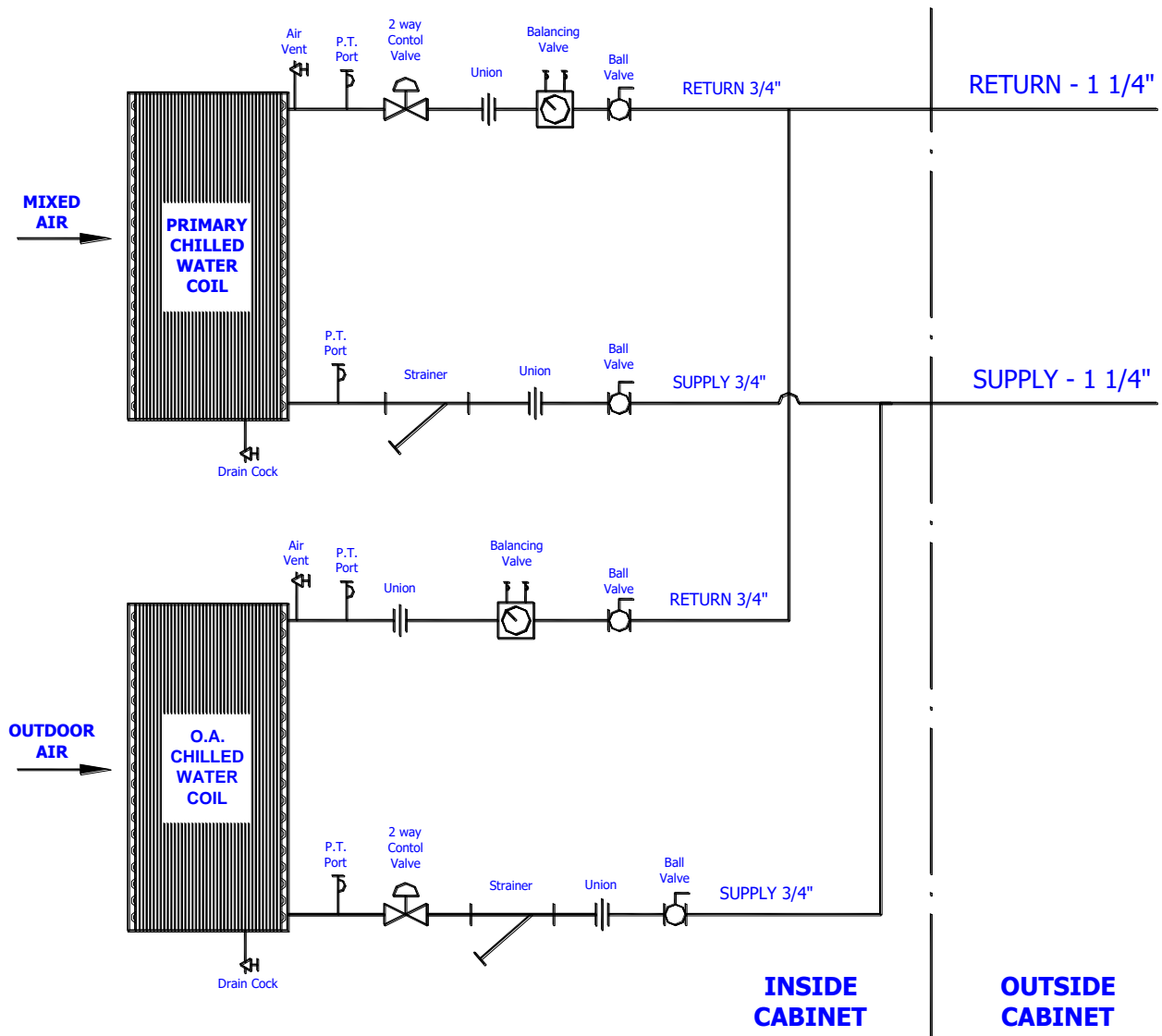

Warning: City water is very corrosive to brass Components. Provide water treatment as soon as the system is charged to avoid premature leaks and/ or failure of internal components.

Refrigeration Circuit

The following is a typical split system refrigeration circuit.

- Notes:**
- 1 Line sizes between the condensing unit(s) and unit ventilator depend on length and elevation changes. Please see additional information in the installation instructions.
 - 2 Field install a sight glass on the liquid line leaving the primary condensing unit.

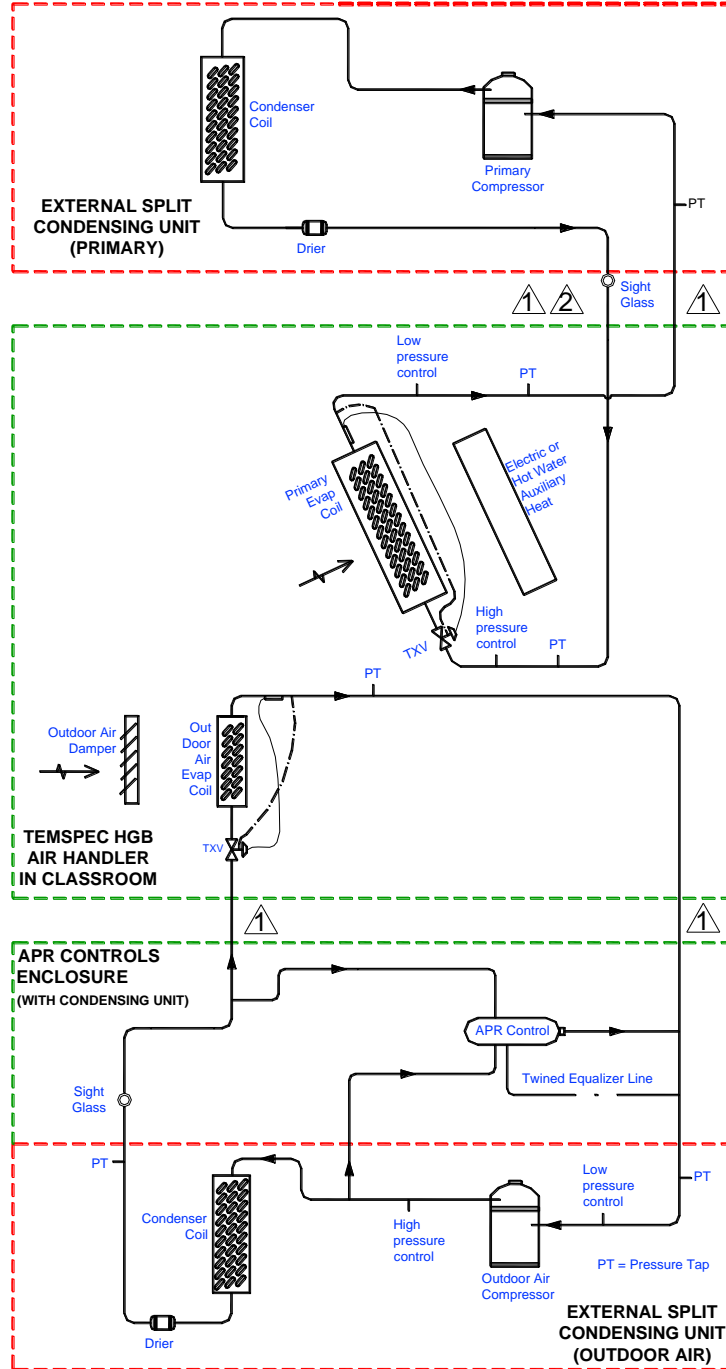

Electrical Circuit

The electrical circuit in the unit ventilator is highly dependent on the controller and sequence that is being utilized. The unit can be supplied with a 115V, 208V, 277V or 460V power. Each unit comes standard with an unfused disconnect. A copy of the electrical schematic can be found folded in a pouch inside of the unit.

Dampers

The outdoor air damper is controlled by a spring return damper actuator. The damper actuator will close the outside air damper upon loss of power. The damper actuator manufacturer can vary. Please refer to the wiring schematic for the damper actuator model type.

Filtration

Typically, 2" disposable filters are provided in the unit. Please refer to the "shop drawings" for specific details on filter construction and thickness. Below are typical filter sizes.

| <u>Location</u> | <u>Filter Size</u> | <u>Quantity Per Unit</u> |
|-----------------|------------------------|--------------------------|
| Return Air | 12" x 24" x 2" nominal | 2 |
| Outdoor Air | 12" x 24" x 2" nominal | 1 |

MAINTENANCE

Servicing the Unit

Access to the components is gained by removing the front access panels. Typically, the panels are fastened by heavy duty Phillips head screws. When removing the access panel (vertical style units), loosen but do not remove the screws. Carefully store the panel in a place where it will not get damaged. The horizontal style units utilize hinged access panels.

CAUTION: Disconnect power before servicing the unit.

The filter access panels have a “kill switch” installed that will shut the supply air fan off once the panel is removed. This will only disconnect the power to the supply air fans. Be sure to disconnect ALL power by turning the remote disconnect switch to the off position.

Maintenance Schedule

Frequency maintenance greatly depends on the surrounding conditions (inside and outside of the building). The following is a typical maintenance schedule for a classroom fan coil unit.

- Every **3 months** – Change filters
- Every **12 months** – Vacuum out drain pans
– Clean strainer in hydronic circuit (if applicable)
- Every **24 months** – Clean evaporator coils
– Vacuum any loose debris from interior of the unit
– Inspect dampers to ensure that there is a proper seal when closed

Changing the Filters

The outdoor and indoor conditions will determine the frequency of filter changes. Temspec recommends that the filters be changed every 3 months as a rule-of-thumb. Note that dirty filters will affect the overall performance of the unit.

To change the filters, open / remove the filter access panel by loosening the Phillips head screws. Unclip the outdoor air filter. Both the outdoor air and the return air filters slide out. Remove and replace.

Cleaning the Evaporator Coils

To clean the evaporator coil, purchase a suitable evaporator coil cleaning solution such as those offered by NU-CALGON (www.nucalgon.com). Follow the manufacturers instructions for use.

Note: Chlorine based or anti-fungal “pucks” or “socks” are acceptable when placed in the evaporator drain pan. Be sure to vacuum the drain pan during the cleaning process.

If the filters are regularly changed, the heating coils do not require cleaning.

WARNING: Do NOT use chlorine-based cleaners or anti-fungal treatments on the aluminum fins of coil.

Motors

Temspec provides motors that are permanently lubricated. No maintenance is required.

TROUBLESHOOTING

Basic Trouble Shooting Guidelines

Problem

- Supply fan not running

- Outdoor air fan does not supply enough air

Action Required

- Verify that the disconnect is in the on position
- Verify that thermostat / controller is not in unoccupied mode (night set-back)
- Check the fan relay to see if it energizing and de-energizing properly
- Check to see if the 24V transformer is defective
- Ensure that wire connections are secured properly
- Check to see if motor is burned out
- Adjust the fan speed control located in the unit.
- Check to see if the unit has a proper seal from the back of the unit to the outside louver. NOTE: If the return air measurement combined with the outdoor air measurement does not equal the supply air measurement, then there is air leakage in the system.

REPLACEMENT PARTS

Limited Warranty

TEMSPEC INCORPORATED warrants the equipment from factory defects in material or workmanship for a period of one year.

For this warranty to be valid, the unit(s) must be installed and maintained in accordance with the manufacturer's printed instructions. It does not cover parts damaged by vandalism, improper installation, maintenance or abuse.

Should any replacement parts be required within the warranty period, they will be supplied at no charge, freight prepaid to the jobsite. The cost of labor or incidental expenses incurred in the repair or replacement of parts does not form part of this warranty.

The warranty period commences from the date of shipment, except when otherwise agreed at the point of sale (see specific warranty terms and conditions for details).

Parts Sales

Contact the factory at: 1-888-TEMSPEC or (905) 670-3595

sales@temspeg.com

Ask for 'parts sales'

Be sure to provide the unit serial number, which is located on the metalized CSA label, on the fan housing, inside the units.