

Operation & Maintenance Manual

VHC & VLC Series Unit Ventilator



IMPORTANT: Read and save this manual for future reference.
This manual is to be left with the equipment owner



Table Of Contents

INTRODUCTION

About the Unit Ventilator	1
Nomenclature for Unit Ventilators with Self-Contained Cooling	1

TYPICAL UNIT LAYOUT

Model VLC 24, VLC 30, VLC 36	2
Model VLC 48, VLC 60 - (ducted)	3
Model VLC 48, VLC 60 - (freeblow)	4
Model VHC 30, VHC 36, VHC 48, VHC 60	5

OPERATION

Sequence of Operation	6
Hot Water Circuit	7
Refrigeration Circuit	8
Electrical Circuit	9
Dampers	9
Optional Powered Exhaust	9
Filtration	9

MAINTENANCE

Servicing the Unit	10
Maintenance Schedule	10
Changing the Filters	11
Cleaning the Condenser Coil	11
Cleaning the Evaporator Coil	12
Motors	12

TROUBLESHOOTING

Basic Troubleshooting Guidelines	13
--	----

REPLACEMENT PARTS

Limited Warranty	14
Part Sales	14

INTRODUCTION

ABOUT THE UNIT VENTILATOR

The Temspec unit ventilator was designed as a means for providing heating, cooling and ventilation to the classroom. Our goal is to help create an enhanced learning environment by focusing on the following points when designing our equipment:

- TEMPERATURE & HUMIDITY CONTROL
- AIR DISTRIBUTION
- SOUND ATTENUATION

By introducing the vertical unit ventilator into the classroom, superior control can be obtained for each room. Because of the unit's ducting capabilities, an even distribution of air can be achieved throughout the room. The unit ventilator is constructed with heavy guage metal and sound absorbing insulation for optimal sound attenuation.

By applying sound engineering principles and through continuous testing, the highest quality of performance is obtained in the unit ventilators.

NOMENCLATURE FOR UNIT VENTILATORS WITH SELF-CONTAINED COOLING

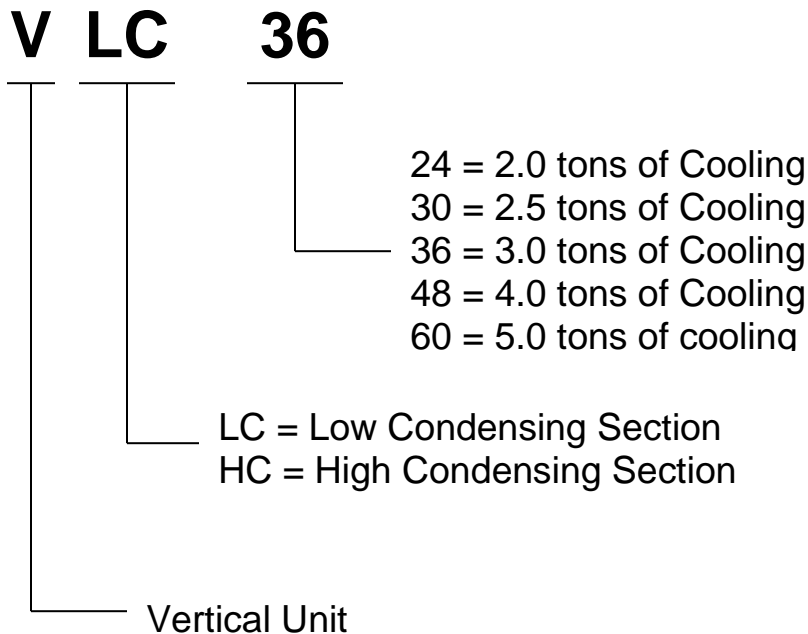

TYPICAL LAYOUT

Models VLC 24, VLC 30, VLC36

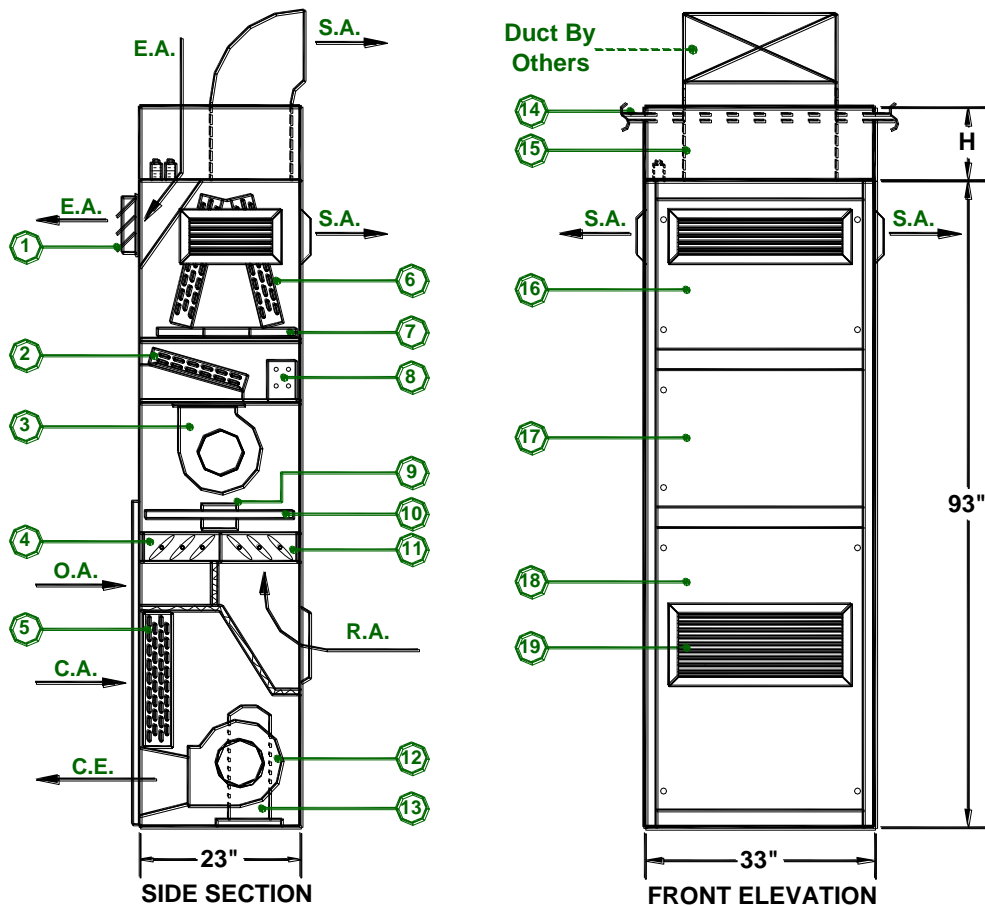

S.A.	Supply Air	O.A.	Outdoor Air	C.E.	Condenser Exhaust Air
R.A.	Return Air	C.A.	Condenser Air	E.A.	Room Exhaust Air

- | | |
|--|---|
| <ol style="list-style-type: none"> 1. Barometric relief damper assembly (optional). 2. Hot water coil. Optional electric or steam coil available. 3. Dual supply air fans. 4. Outdoor air damper. 5. Condenser coil. 6. DX cooling coil. 7. Drain pan. 8. Electrical box / controls enclosure. 9. Mixed air damper actuator. 10. Filter. | <ol style="list-style-type: none"> 11. Return air damper. 12. Single condenser fan. 13. Compressor. 14. Ceiling tile. 15. Top extension /duct shroud to suit ceiling height (optional). 16. Coil access panel (removable) with optional double deflection discharge grille. 17. Filter access panel, hinged. 18. Removable access panel. 19. Heavy duty return air grille. |
|--|---|

NOTE: The component arrangement shown above may vary slightly from that in the unit ventilator supplied.

TYPICAL LAYOUT

Models VLC 48, VLC 60 (ducted configuration)

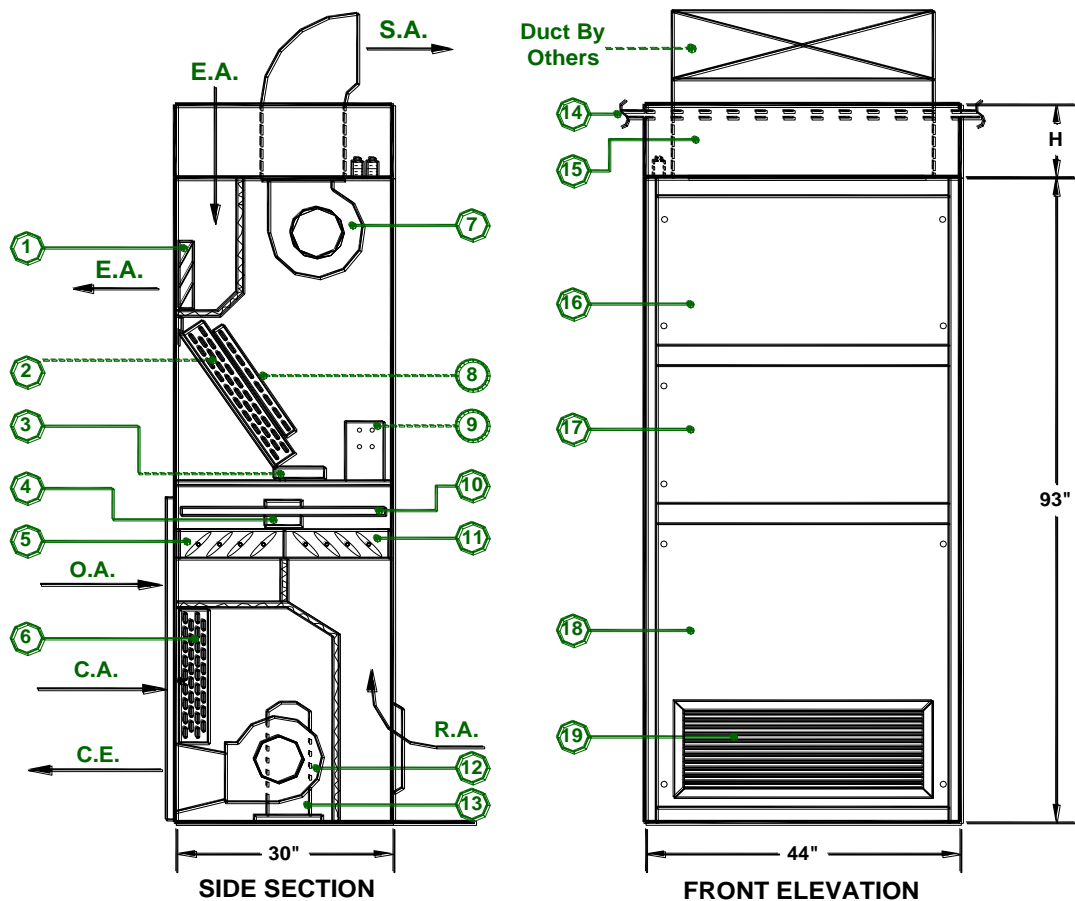

S.A.	Supply Air	O.A.	Outdoor Air	C.E.	Condenser Exhaust Air
R.A.	Return Air	C.A.	Condenser Air	E.A.	Room Exhaust Air

- | | |
|---|--|
| 1. Barometric relief damper assembly (optional). | 11. Return air damper. |
| 2. DX cooling coil. | 12. Dual condenser fans. |
| 3. Drain pan. | 13. Compressor. |
| 4. Spring return mixed air damper actuator. | 14. Ceiling tile. |
| 5. Outdoor air damper. | 15. Top extension / duct shroud to suit ceiling height (optional). |
| 6. Condenser coil. | 16. Coil access panel, removable. |
| 7. Dual supply air fans. | 17. Filter access panel, hinged. |
| 8. Hot water coil. Optional electric or steam coil available. | 18. Removable access panel. |
| 9. Electrical box / controls enclosure. | 19. Heavy duty return air grille. |
| 10. Filters. | |

NOTE: The component arrangement shown above may vary slightly from that in the unit ventilator supplied.

TYPICAL LAYOUT

Models VLC 48, VLC 60 (freeblow configuration)

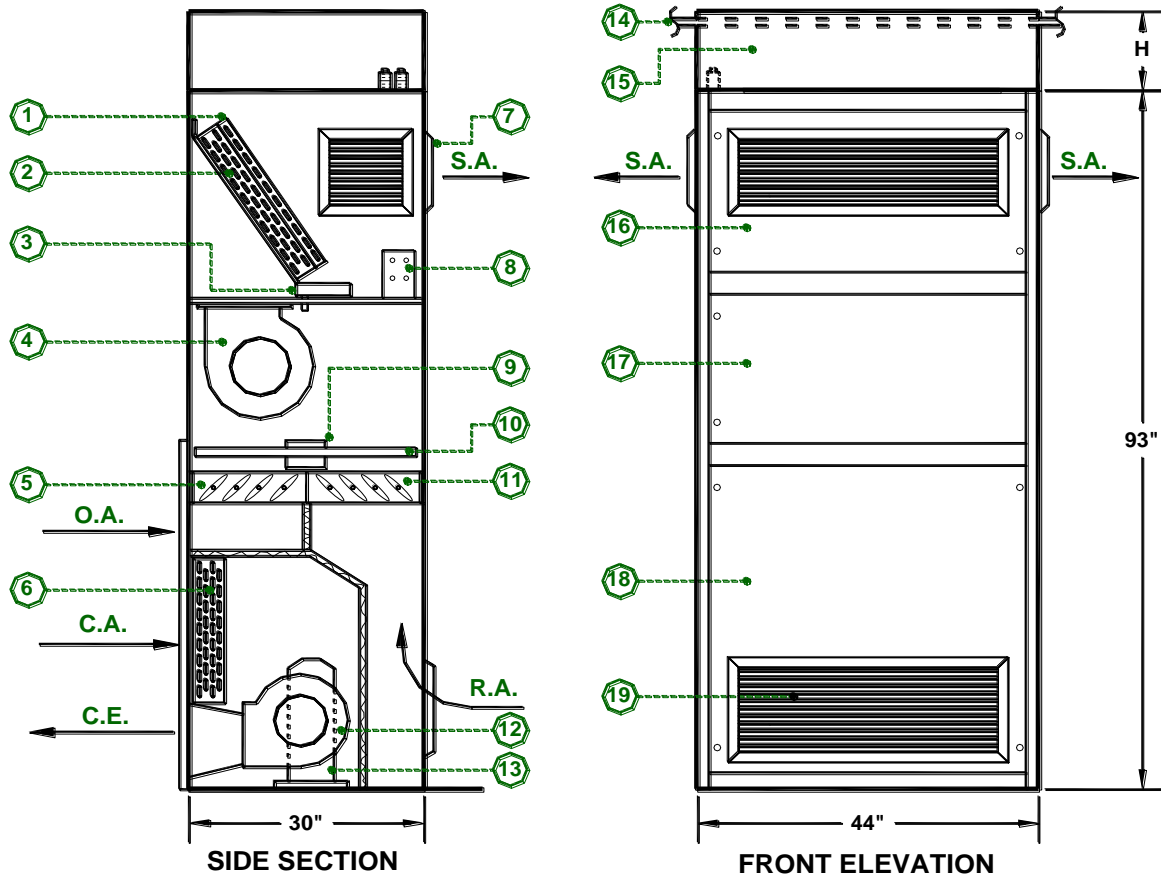

S.A. Supply Air	O.A. Outdoor Air	C.E. Condenser Exhaust Air
R.A. Return Air	C.A. Condenser Air	

- | | |
|---|--|
| <ul style="list-style-type: none"> 1. Hot water coil. Optional electric or steam coil available. 2. DX cooling coil. 3. Drain pan. 4. Dual supply air fans. 5. Outdoor air damper. 6. Condenser coil. 7. Supply air grilles (double deflection). 8. Electrical box / controls enclosure. 9. Mixed air damper actuator. 10. Filters. | <ul style="list-style-type: none"> 11. Return air damper. 12. Compressor. 13. Dual condenser fans. 14. Ceiling tile. 15. Top extension to suit ceiling height (optional). 16. Coil access panel (removable) with front double deflection grille. 17. Filter access panel, hinged. 18. Removable access panel. 19. Heavy duty return air grille. |
|---|--|

NOTE: The component arrangement shown above may vary slightly from that in the unit ventilator supplied.

TYPICAL LAYOUT

Models VHC 30, VHC 36, VHC 48, VHC 60 (ducted configuration)

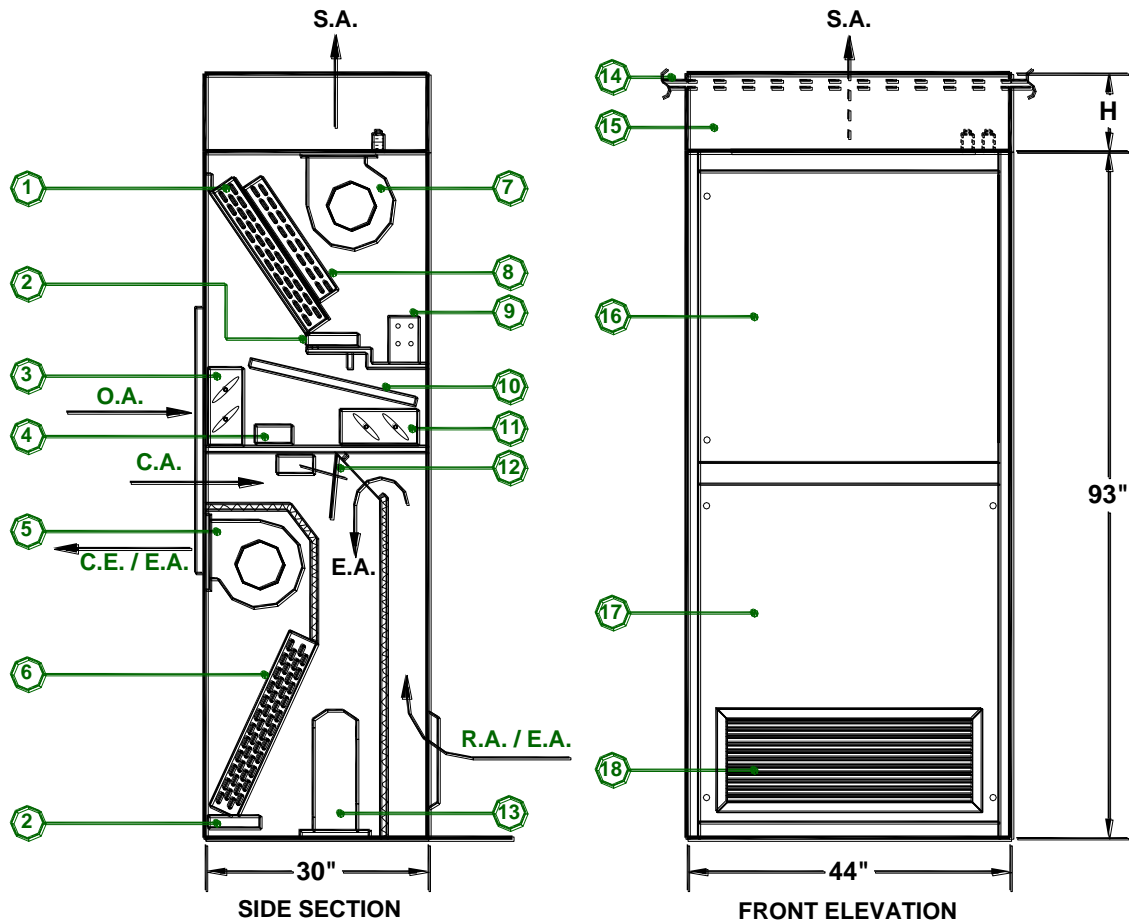

S.A.	Supply Air	O.A.	Outdoor Air	C.E.	Condenser Exhaust Air
R.A.	Return Air	C.A.	Condenser Air	E.A.	Room Exhaust Air

1. DX cooling coil.
2. Drain pan.
3. Outdoor air damper.
4. Mixed air damper actuator.
5. Dual condenser exhaust / powered exhaust fans.
6. Condenser coil.
7. Supply air fan(s).
8. Hot Water Coil. Optional electric or steam coil available.
9. Electrical box / controls enclosure.

10. Filters.
11. Return air damper.
12. Modulating powered exhaust damper and actuator module (optional).
13. Compressor.
14. Ceiling tile.
15. Top extension / duct shroud to suit ceiling height (optional).
16. Filter/coil hinged access panel.
17. Removable access panel.
18. Heavy duty return air grille.

NOTE: The component arrangement shown above may vary slightly from that in the unit ventilator supplied.

OPERATION

Typical Modes of Operation

The following are typical modes of operation for a classroom unit ventilator. Please refer to the manual provided by the control's contractor for a more specific controls sequence.

1. **Unoccupied Mode**

During the "unoccupied heat" mode (night set-back) space temperature is maintained by a signal from the thermostat/controller to either the modulating control valve or electric coil. The powered exhaust damper (if applicable) and the outdoor air damper are fully closed, and the return air damper is fully open. The supply air fan operates on call for heating or cooling from the thermostat/controller.

2. **Occupied Mode**

The unit ventilator is switched to "occupied mode" by the thermostat/controller. In this mode a signal is sent from the thermostat/controller to either the modulating control valve or electric coil to maintain room temperature at set point. The outdoor air damper is held at a minimum position in the heating and mechanical cooling modes. The supply air fan runs continuously.

3. **Economizer (up to 100% outdoor air)**

The first stage of cooling is the economizer mode during which all stages of heating are off. The outdoor air and the return air dampers modulate to maintain the room temperature at the economizer set point. If the mixed air falls to a programmed temperature (usually 52°F) the outdoor air damper will modulate towards closed until the mixed air temperature rises again (typically to 55°F). In this free cooling mode, the ability of the unit ventilator to provide sufficient cooling is limited only by the outdoor air temperature and the total C.F.M. rating of the unit.

4. **Mechanical Cooling**

The unit ventilator utilizes the self-contained refrigeration section incorporated within the unit (DX coil, condenser coil, compressor and refrigerant expansion device). The system maintains the cooling set point by cycling on call from the thermostat/controller. In this mode the outdoor air damper will return to minimum position.

5. **Freeze Protection**

For units with a steam or hot water coil, freeze protection is usually incorporated. This can be by either a low limit temperature control (autoreset or manual reset) or by using a supply air sensor and programming from the controller. When a mixed air temperature is determined to be too low, then the outdoor air damper will close, and the control valve will fully open. The fan can also be shut down until the temperature returns to normal levels. The low limit temperature control (freezestat) should be located at the leaving air side of the heating coil.

6. **Humidistat & Hot Gas Reheat (Optional for VHC series units only)**

A room humidistat sensor is included in the return air stream. The humidistat has a set point of 55% R.H. (adjustable). When the room temperature falls to the cooling set point and the humidistat set point has not been satisfied, the hot gas reheat coil provides reheat to maintain the cooling set point in the room (to avoid over cooling in the space). The compressor operates under this condition. When the humidity set point is satisfied, the reheat coil is de-energized.

Hot Water Circuit

The following are typical hot water piping schematics for a unit ventilator. Please refer to the unit ventilator shop drawings for a more specific layout.

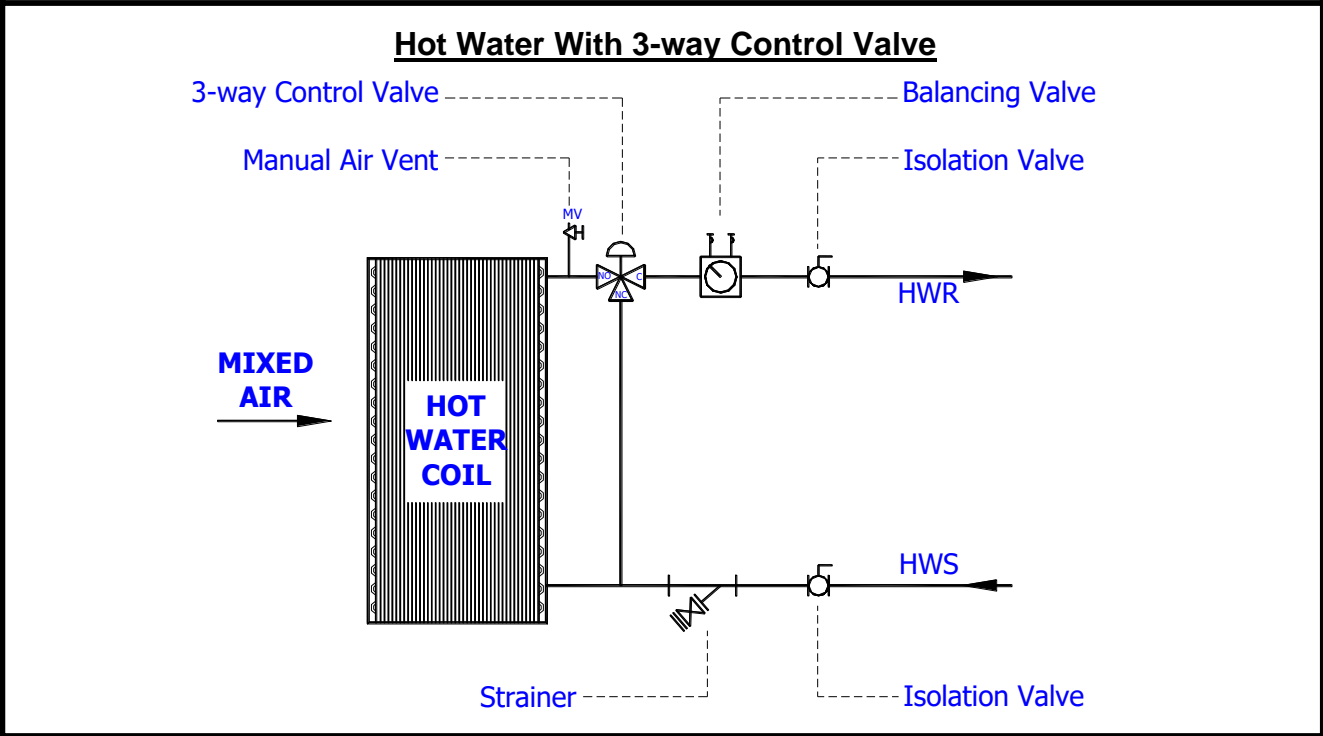
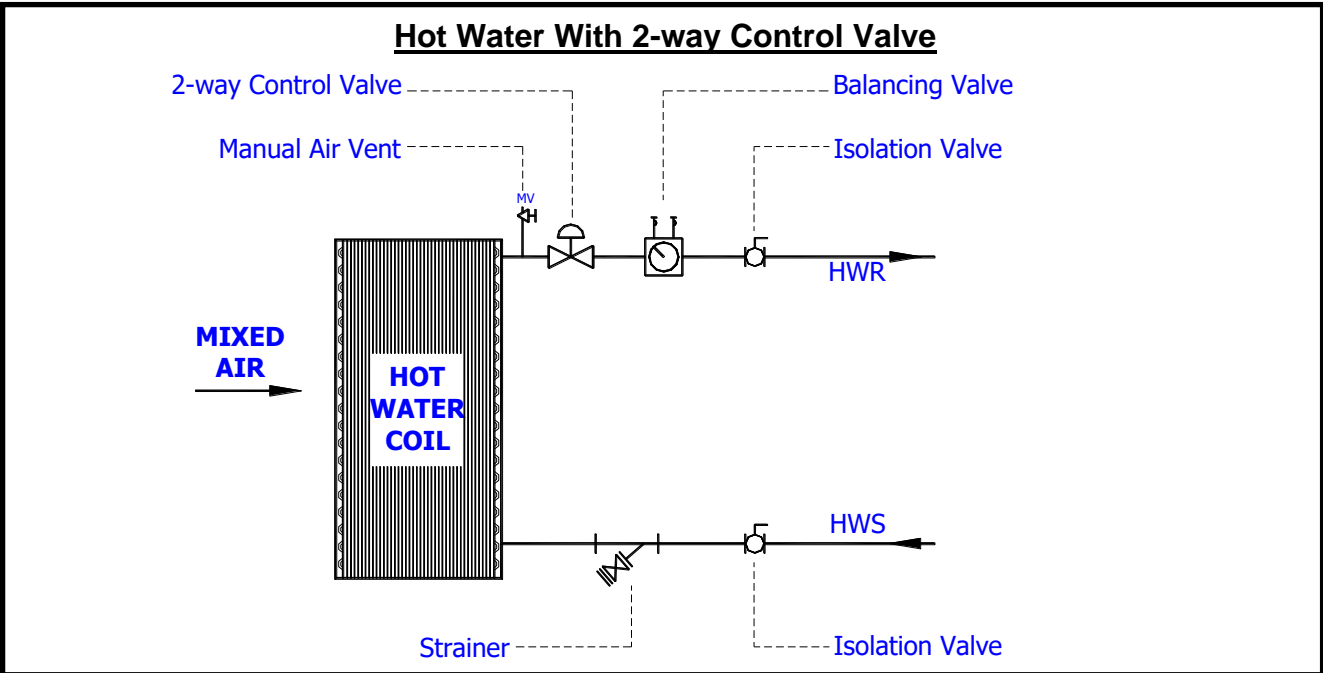

Refrigeration Circuit

The following is a typical self-contained refrigeration circuit.

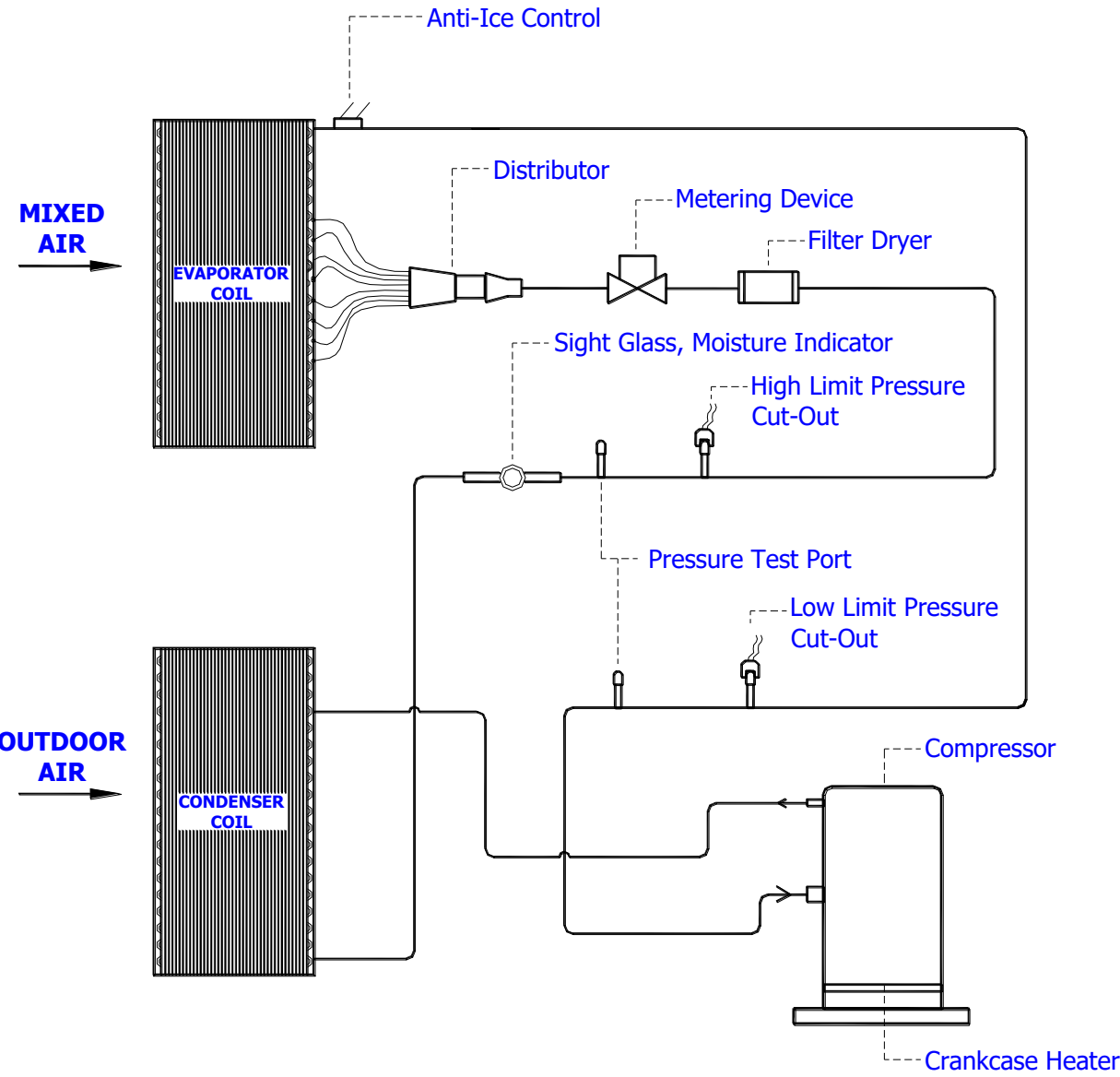



Electrical Circuit

The electrical circuit in the unit ventilator is dependent on the controller and sequence that is being utilized. The unit can be supplied with a 208V, 277V or 460V power supply. The unit is equipped with an unfused service disconnect. A copy of the electrical schematic can be found folded in a pouch inside of each unit ventilator, located on the electrical enclosure or supply air fan housing.

Dampers

The outdoor air dampers and return air dampers are mechanically linked. As the outdoor air damper opens, the return air damper closes. A spring return damper actuator is connected to a linkage set that extends to both sets of dampers. The damper actuator manufacturer can vary. Please refer to the wiring schematic for the damper actuator model type.

Powered Exhaust (optional)

Internal powered exhaust is an optional feature that is provided with the VHC series. This feature comes with a spring return damper actuator that is separate from the one used to control the outside air and return air dampers. However, the powered exhaust damper actuator is electrically linked to the outside air damper. As the outside air damper opens, so does the powered exhaust damper.

Filtration

Typically 1” disposable filters are provided in the unit. Please refer to the “shop drawings” for specific details on filter construction and thickness. Below are sizes and quantity per unit for the different model types.

<u>Model Number</u>	<u>Filter Size</u>	<u>Quantity Per Unit</u>
VLC 24, VLC 30, VLC 36	20” x 24” nominal	1
VLC 48, VLC 60	16” x 24” nominal	2
VHC 36, VHC 48, VHC 60	20” x 25” nominal	2

MAINTENANCE

Servicing The Unit

Maintenance to the unit is accomplished by removing the front access panels. Typically, the panels are secured by heavy duty Philips (star or cross shape) head screws. When removing the access panel, loosen but do not remove the screws. Carefully store the panel in a place where it will not get damaged. Use caution as some access panels are heavy.

CAUTION: Disconnect power at the remote circuit breaker before servicing the unit.

The unit comes fitted with a “fan kill switch” that de-energizes the supply air fan(s) when the filter access panel is removed / opened. This will only disconnect the power to the supply air fans. Be sure to disconnect ALL power by turning the remote circuit breaker to the off position.

To access the condenser section, you must remove a secondary panel located directly behind the return air access panel.

Maintenance Schedule

Interior and exterior environmental conditions will influence the required frequency of coil cleaning and filter change operations . The following is a typical maintenance schedule for a classroom unit ventilator.

- | | |
|-------------------------|--|
| Initial Start-Up | <ul style="list-style-type: none"> – Change out construction filters. – Verify that air paths are free of construction debris and that fans turn freely – Verify compressor rotation – Verify outdoor air minimum position |
| Every 3 months | <ul style="list-style-type: none"> – Change filters |
| Every 12 months | <ul style="list-style-type: none"> – Clean condenser coil (at the beginning of the cooling season) – Vacuum out evaporator drain pan – Vacuum any loose debris from unit’s interior condenser section – Clean strainer in the hydronic circuit (if applicable) |
| Every 24 months | <ul style="list-style-type: none"> – Clean evaporator coil – Vacuum any loose debris from unit’s interior return air section – Inspect dampers to ensure that there is a proper seal when closed |

Changing the Filters

The outdoor and indoor conditions of your area will determine the frequency of filter changes. Temspec recommends that the filters be changed every 3 months as a rule-of-thumb. Note that dirty filters adversely affect the overall performance of the unit.

To change the filters, open / remove the filter access panel by loosening the Philips head screws. On the VLC series units, simply slide out the old filters and replace them with the new ones. On the VHC series units, unclip the filters. Be sure to note the airflow direction that is marked on the filter(s).

Cleaning the Condenser Coil

The following are the recommended steps to cleaning the condenser coil.

CAUTION: Disconnect power at the remote circuit breaker before servicing the unit.

1. Clean debris and leaves from between the blades of the exterior louver.
2. **VLC series:** Unfasten the removable section of the louver from the exterior side of the building.

VHC series: Remove the unit ventilator return air access panel and condenser access panel from inside the room.
3. Vacuum the entering air face of the condenser coil using a soft bristle attachment. Be careful not to bend any of the aluminum fins on the coil.
4. Use a foaming coil cleaning chemical (such as “Foam-Brite” from NU-CALGON, product# 4178-08, www.nucalgon.com). Follow the manufacturers instructions for safe handling and personal protective equipment.

WARNING: Do NOT use condenser coil cleaning compounds on the evaporator or hot water coils.

WARNING: Do NOT use chlorine based cleaners or anti-fungal treatments on the aluminum fins of any coil.

Depending on the wind conditions and building pressurization, a portable fan may be required in the room to ensure that the fumes are properly exhausted out of the building (VHC series only).

5. Using a wet / dry shop vac, remove any rinse water from the condenser coil pan.
6. Replace access panels and return to normal operation.

Drain Pan Instruction

- Please check the drain pan for proper drainage as part of commissioning.
- Check to make sure the drain pan overflow switch did not come loose or shift during shipping
- The unit should be checked to ensure the drain pan is level, free of debris, and the drain line properly connected to the stub-out

Cleaning the Evaporator and Hot Water

Cleaning the Evaporator and Hot Water Coils

CAUTION: Disconnect power before servicing the unit.

WARNING: Do NOT use condenser coil cleaning compounds on the evaporator or hot water coils.

To clean the evaporator coil, purchase a suitable evaporator coil cleaning solution such as those offered by NU-CALGON. Follow the manufacturer's instructions for use.

Note: Chlorine based or anti-fungal "pucks" or "socks" are acceptable when **placed in the evaporator drain pan**. Be sure to vacuum the drain pan after the cleaning process is complete and prior to adding the anti-fungal component.

WARNING: Do NOT use chlorine based cleaners or anti-fungal treatments on the aluminum fins of any coil.

Motors

Temspec provides motors that are permanently lubricated. No maintenance is required.

Caution: Temspec does not recommend the use of a unit ventilators during construction/drywall installation as a space heater or air conditioner. Motor exposure to drywall dust can reduce motor life and leads to premature failure.



TROUBLESHOOTING

Basic Trouble Shooting Guidelines

Problem

- Supply fan not running

Action Required

- Verify that the disconnect is in the “on” position
- Verify that door micro-switch “kill switch” is completely depressed and operating correctly
- Verify that thermostat / controller is not in unoccupied mode (night set-back)
- Check manual reset controls (electric heat, high refrigerant pressure controls and low limit temperature control) and ensure that they have not been tripped.
- Check the fan relay to observe if it is energizing and de-energizing properly
- Check that the 24V transformer is working properly
- Ensure that the wire connections are secured properly

-
- Compressor and condensing fans cycle on and off

- Ensure that there are no obstructions to the condenser air path. Obstructions will cause the unit to cut-out on high head pressure.
- Check refrigerant charge. If the charge is too low, the unit will cut-out on low pressure. The Refrigerant type and amount is posted on the silver CSA label located on the electrical enclosure or fan housing.



REPLACEMENT PARTS

Limited Warranty

TEMSPEC INCORPORATED warrants the equipment from factory defects in material or workmanship for a period of one year.

For this warranty to be valid, the unit(s) must be installed and maintained in accordance with the manufacturer's printed instructions. It does not cover parts damaged by vandalism, improper installation, maintenance or abuse.

Should any replacement parts be required within the warranty period, they will be supplied at no charge, freight prepaid to the jobsite. The cost of labor or incidental expenses incurred in the repair or replacement of parts does not form part of this warranty.

The warranty period commences from the date of shipment, except when otherwise agreed at the point of sale (see specific warranty terms and conditions for details).

Parts Sales

Contact the factory at: 1-888-TEMSPEC or (905) 670-3595

sales@temspec.com

Ask for ' parts sales '

Be sure to provide the unit serial number, which is located on the metalized CSA label, on the fan housing, inside the units.