

Operation & Maintenance Manual

VHW Geothermal/Water Source Heat Pump



IMPORTANT: Read and save this manual for future reference.
This manual is to be left with the equipment owner

Table of Contents

INTRODUCTION

About the Water Source/Geothermal Heat Pump	1
Nomenclature for Heat Pumps	1

TYPICAL UNIT LAYOUT

Model VHW 36/48/60 (ducted)	2
-----------------------------------	---

OPERATION

Sequence of Operation	3
Hot Water Circuit	4
Water Side Circuit	5
Refrigeration Circuit.....	6
Electrical Circuit	7
Dampers.....	7
Optional 100% Economizer	7
Optional Powered Exhaust.....	7
Filtration	7

MAINTENANCE

Servicing the Unit	8
Maintenance Schedule.....	8
Changing the Filters	9
Waterside Component Maintenance	9
Cleaning the Evaporator Coil	10
Motors	10
Cleaning the Energy Recovery Wheel.....	10

TROUBLESHOOTING

Basic Troubleshooting Guidelines.....	11
---------------------------------------	----

REPLACEMENT PARTS

Limited Warranty	12
Part Sales.....	12

INTRODUCTION

ABOUT THE HEAT PUMP

The Temspec water source/geothermal heat pump (WSHP/GHP) was designed as a means for providing energy efficient self-contained heating, cooling and ventilation to the classroom. Our goal is to help create an enhanced learning environment by focusing on the following points when designing our equipment:

- TEMPERATURE & HUMIDITY CONTROL
- AIR DISTRIBUTION
- SOUND ATTENUATION
- ENERGY EFFICIENCY

By introducing the WSHP/GHP into the classroom, superior control can be obtained for each room. Because of the unit's ducting capabilities, an even distribution of air can be achieved throughout the room. The WSHP/GHP is constructed with heavy guage metal and sound absorbing insulation for optimal sound attenuation.

By applying sound engineering principles and through continuous testing, the highest quality of performance is obtained in the heat pump.

NOMENCLATURE FOR UNIT VENTILATORS WITH GEOTHERMAL HEAT PUMPS

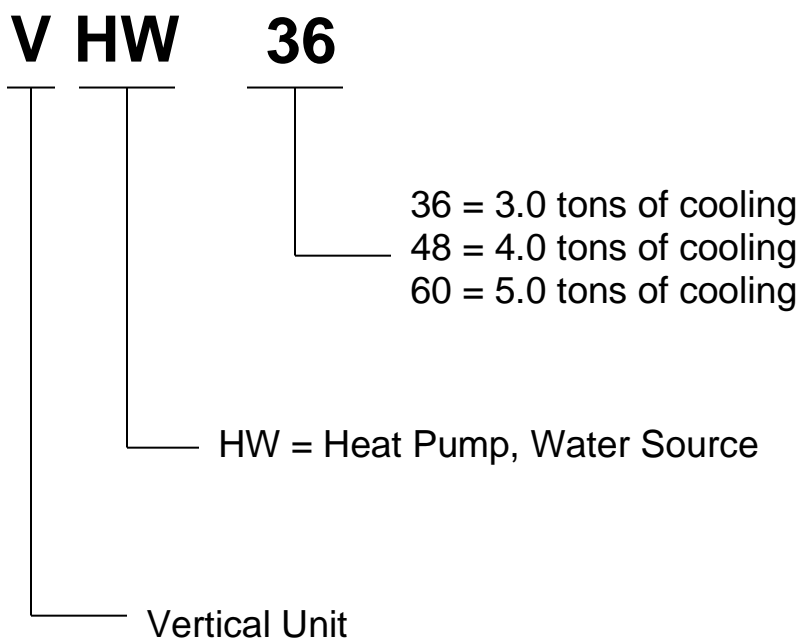

TYPICAL LAYOUT

Models VHW 36, VHW 48, VHW 60 (ducted configuration)

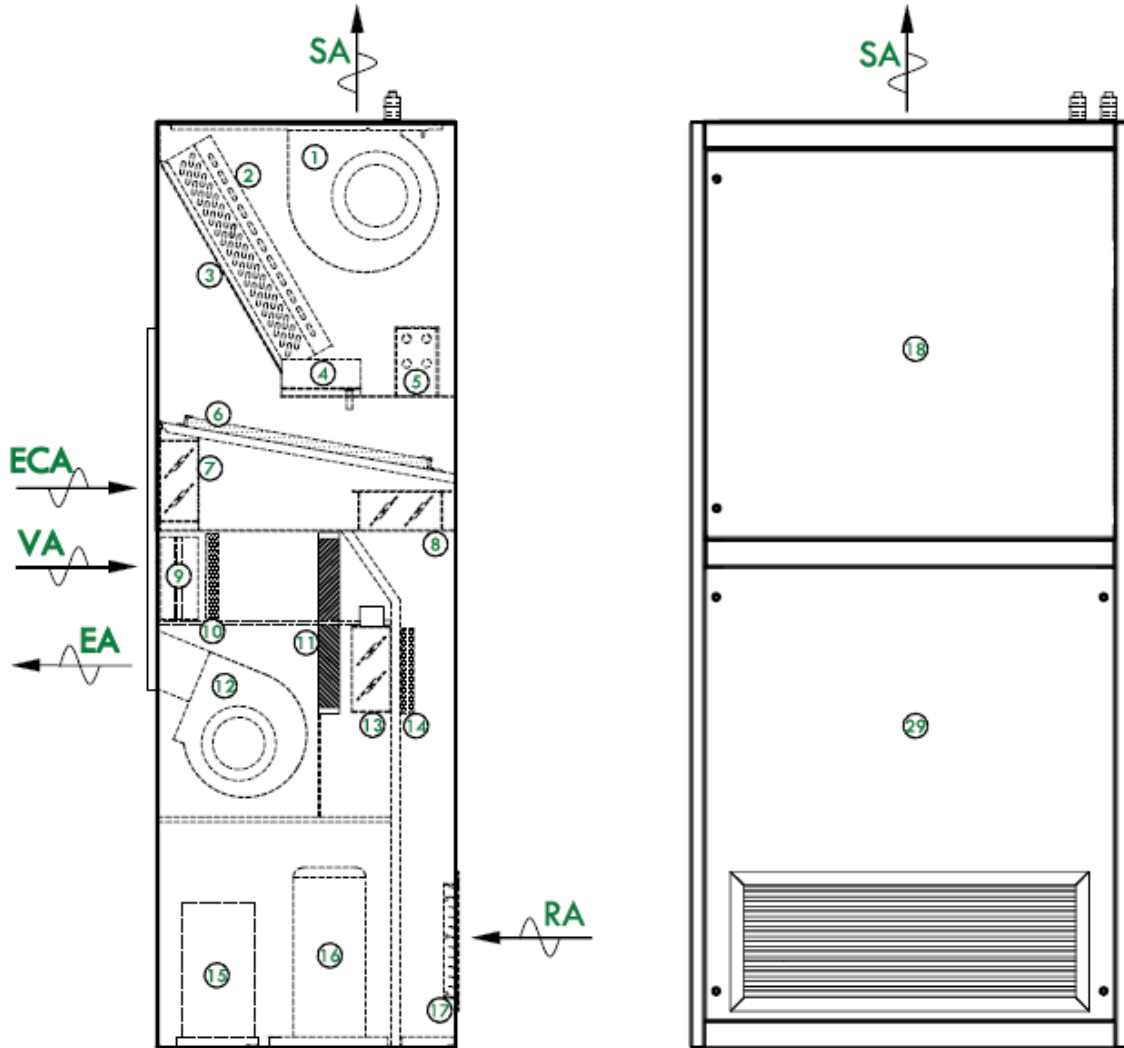

SA = Supply Air
RA = Return Air

VA = Ventilation Air
EA = Exhaust Air

ECA = Economizer Air

ITEM NO.	DESCRIPTION	ITEM NO.	DESCRIPTION	ITEM NO.	DESCRIPTION
1.	Supply Air Fan (s)	8.	Return Air Damper and Actuator	15.	Heat Exchanger
2.	Auxiliary Hot Water / Electric Coil	9.	Energy Recovery Damper with Actuator	16.	Scroll Compressor, R-410A
3.	Indoor Coil	10.	Energy Recovery Exhaust Air Filter	17.	Heavy Duty Return Air Grille
4.	Drain Pan	11.	Energy Recovery Enthalpy Wheel	18.	Hinged Coil / Filter Access Panel
5.	Electrical / Controls Enclosure	12.	Energy Recovery Exhaust Fan	19.	Removable Return Air Access Panel
6.	Mixed Air Filters	13.	Powered Exhaust Damper with Actuator		
7.	Economizer Damper and Actuator	14.	Energy Recovery Intake Air Filter		

NOTE: The component arrangement shown above may vary slightly from that in the unit supplied.



OPERATION

Typical Modes of Operation

The following are typical modes of operation for a classroom unit ventilator. Please refer to the manual provided by the controls contractor for a more specific controls sequence.

1. **Unoccupied Mode**

During the “unoccupied heat” mode (night set-back) space temperature is maintained by a signal from the thermostat/controller to either the modulating control valve or electric coil. The powered exhaust damper (if applicable) and the outdoor air damper are fully closed and the return air damper is fully open. The supply air fan operates on call for heating or cooling from the thermostat/controller.

2. **Occupied Mode**

The unit ventilator is switched to “occupied mode” by the thermostat/controller. In this mode a signal is sent from the thermostat/controller to either the modulating control valve or electric coil to maintain room temperature at set point. The outdoor air damper is held at a minimum position in the heating and mechanical cooling modes. The supply air fan runs continuously.

3. **Economizer (up to 100% outdoor air)**

The first stage of cooling is the economizer mode during which all stages of heating are off. The outdoor air and the return air dampers modulate to maintain the room temperature at the economizer set point. If the mixed air falls to a programmed temperature (usually 52°F) the outdoor air damper will modulate towards closed until the mixed air temperature rises again (typically to 55°F). In this free cooling mode the ability of the unit ventilator to provide sufficient cooling is limited only by the outdoor air temperature and the total C.F.M. rating of the unit.

4. **Mechanical Cooling**

The unit ventilator utilizes the self-contained refrigeration section incorporated within the unit (DX coil, condenser coil, compressor and refrigerant expansion device). The system maintains the cooling set point by cycling on call from the thermostat/controller. In this mode the outdoor air damper will return to minimum position.

5. **Freeze Protection**

For units with a steam or hot water coil, freeze protection is usually incorporated. This can be by either a low limit temperature control (autoreset or manual reset) or by using a supply air sensor and programming from the controller. When a mixed air temperature is determined to be too low, then the outdoor air damper will close and the control valve will fully open. The fan can also be shut down until the temperature returns to normal levels. The low limit temperature control (freezestat) should be located at the leaving air side of the heating coil.

6. **Humidistat & Hot Gas Reheat (Optional for VHC series units only)**

A room humidistat sensor is included in the return air stream. The humidistat has a set point of 55% R.H. (adjustable). When the room temperature falls to the cooling set point and the humidistat set point has not been satisfied, the hot gas reheat coil provides reheat to maintain the cooling set point in the room (to avoid over cooling in the space). The compressor operates under this condition. When the humidity set point is satisfied, the reheat coil is de-energized.



Hot Water Circuit

The following are typical auxiliary hot water piping schematic for a heat pump. Please refer to the shop drawings for a more specific layout.

Hot Water with 2-Way Control Valve

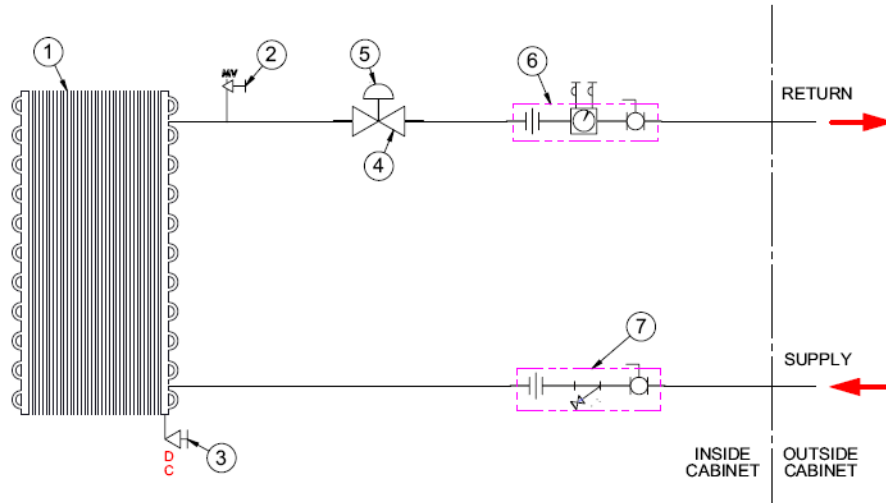

ITEM NO.	QTY	DESCRIPTION
1.	1	Hot Water Coil
2.	1	Manual Air Vent
3.	1	Drain Cock
4.	1	Control Valve - 2 way

ITEM NO.	QTY	DESCRIPTION
5.	1	Actuator - Modulating
6.	1	Balance Valve / Ball Valve / Union
7.	1	Strainer / Ball Valve / Union

Hot Water with 3-Way Control Valve

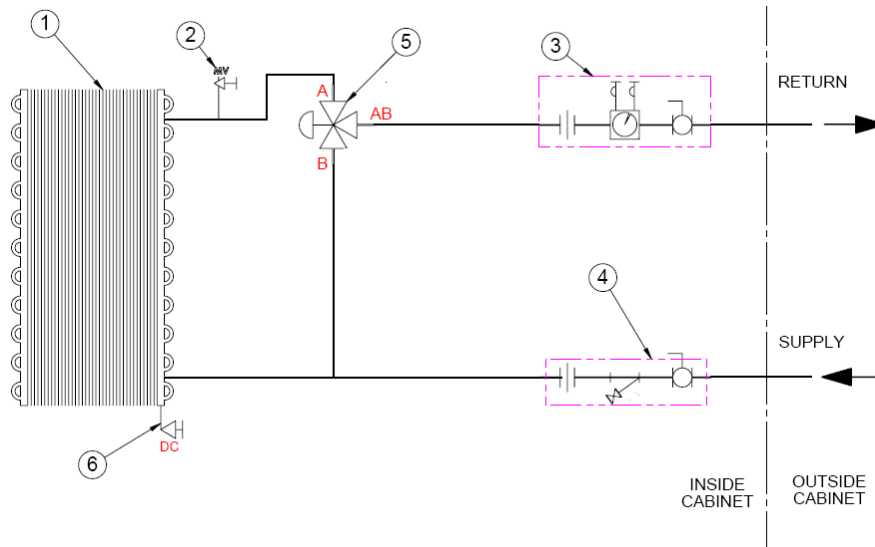

ITEM NO.	QTY	DESCRIPTION
1.	1	Hot Water Coil
2.	1	Manual Air Vent
3.	1	Balance Valve / Ball Valve / Union

ITEM NO.	QTY	DESCRIPTION
4.	1	Strainer / Ball Valve / Union
5.	1	Valve - 3 Way - Modulating
6.	1	Drain Cock

Waterside Circuit

The following is a typical geothermal/water source heat pump waterside schematic.

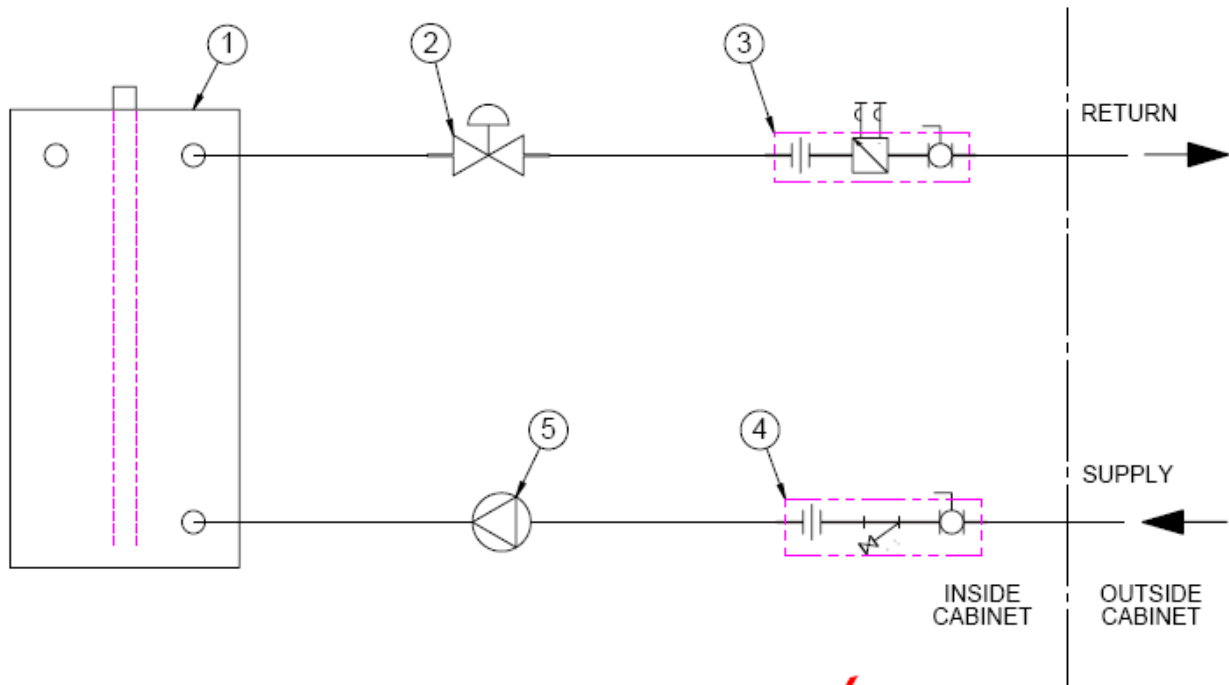

PRELIMINARY

ITEM NO.	QTY	DESCRIPTION
1.	1	Heat Exchanger with Bi-Directional Receiver
2.	1	Valve - 2 Way - ON/OFF
3.	1	Valve - Balance
4.	1	Strainer / Ball Valve / Union
5.	1	Circulator Pump (Optional)

Refrigeration Circuit

The following is typical geothermal / water source heat pump refrigeration schematic.

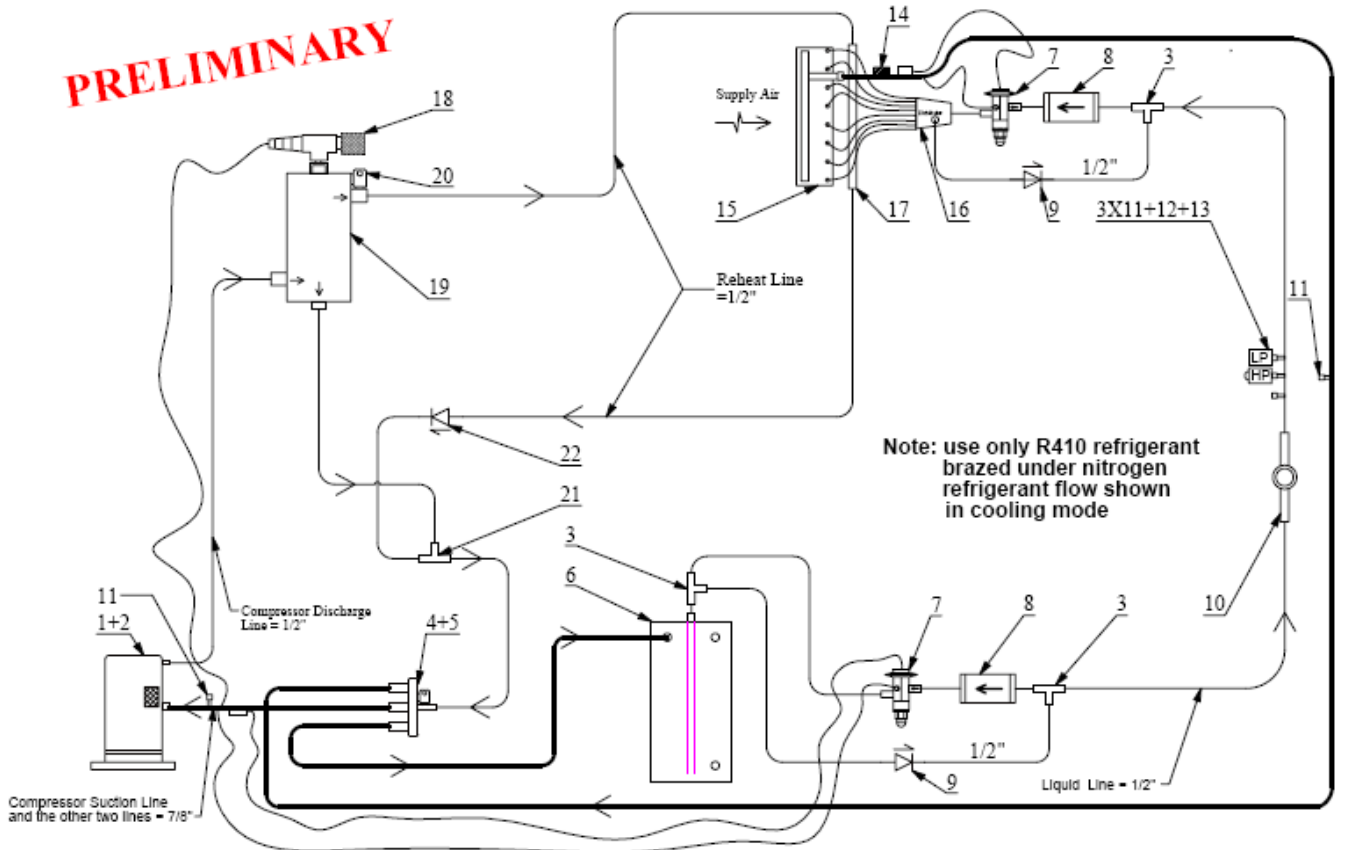

ITEM NO.	QTY	DESCRIPTION	ITEM NO.	QTY	DESCRIPTION
1.	1	Compressor - R410A	12.	1	Sensor - Hi Pressure - NC
2.	1	Crankcase heater	13.	1	Sensor - Low Pressure Ref - NO
3.	3	Tee - Copper	14.	1	Controller - Anti-Ice
4.	1	Valve - Reversing - 4 Way - R410A	15.	1	Coil - DX
5.	1	Coil for Reversing Valve	16.	1	Nozzle
6.	1	Heat Exchanger with Bi-Directional Receiver	17.	1	Coil - DX (Optional for Reheat)
7.	2	Valve - TX - R410A	18.	1	Swivel Tee (Optional for Reheat)
8.	2	Filter Dryer	19.	1	3 Way Valve (Optional for Reheat)
9.	2	Check Valve	20.	1	Coil for NC Solenoid Valve (Optional for Reheat)
10.	1	Sight Glass	21.	1	Tee - Copper (Optional for Reheat)
11.	5	Valve - Access	22.	1	Check Valve (Optional for Reheat)

Electrical Circuit

The electrical circuit in the heat pump is dependent on the controller and sequence that is being utilized. The unit can be supplied with a 208V, 277V or 460V power supply. The unit is equipped with an unfused service disconnect. A copy of the electrical schematic can be found folded in a pouch inside of each geothermal/water source, located on the electrical enclosure or supply air fan housing.

Dampers

All the included damper assemblies have airfoil section extruded aluminum blades with flexible seal blade tips and jamb seals. The damper actuator manufacturer can vary. Please refer to the wiring schematic for the damper actuator model type and control.

100% Economizer (optional)

100% economizer is an option feature on the water source heat pumps. This module includes a modulating spring return damper actuator and aluminum damper assembly and associated controls.

100% Powered Exhaust (optional)

Internal powered exhaust is an optional feature that may be provided with the VHW series. This feature comes with a spring return actuated aluminum damper, direct drive fan and ECM motor. It shall operate in tandem with the outdoor air damper to be able to provide up to 100 % power exhaust

Filtration

Typically 1" disposable filters are provided in the unit. Please refer to the "shop drawings" for specific details on filter construction and thickness for your unit. Below are the sizes and quantity for the typical base unit and additional filters for optional modules.

<u>Model Number</u>	<u>Filter Size</u>	<u>Quantity per Unit</u>
VHW 36/48/60	18" x 25" nominal	2
Energy Recovery Module	12" x 20" nominal	2

MAINTENANCE

Servicing the Unit

Maintenance to the unit is accomplished by removing the front access panels. Typically the panels are secured by heavy duty Phillips (star or cross shape) head screws. When removing the access panel, loosen but do not remove the screws. Carefully store the panel in a place where it will not get damaged. Use caution as some access panels are heavy.

CAUTION: Disconnect power at the remote circuit breaker before servicing the unit.

The unit comes fitted with a “fan kill switch” that de-energizes the supply air fan(s) when the filter access panel is removed / opened. This will only disconnect the power to the supply air fans. Be sure to disconnect ALL power by turning the remote circuit breaker to the off position.

To access the compressor and ERV sections, you must remove a secondary panels located directly behind the return air access panel.

Maintenance Schedule

Interior and exterior environmental conditions will influence the required frequency of coil cleaning and filter change operations. The following is a typical maintenance schedule for a classroom unit ventilator.

- | | |
|-------------------------|---|
| Initial Start-Up | <ul style="list-style-type: none">• Change out construction filters.• Verify that air paths are free of construction debris and that fans turn freely• Verify compressor rotation• Verify outdoor air minimum position |
| Every 3 months | <ul style="list-style-type: none">• Change filters |
| Every 12 months | <ul style="list-style-type: none">• Vacuum out evaporator drain pan• Clean strainer in the hydronic circuit (if applicable)• Check condition of ERV desiccant wheel, clean if necessary |
| Every 24 months | <ul style="list-style-type: none">• Clean evaporator coil• Vacuum any loose debris from unit's interior return air section• Inspect dampers to ensure that there is a proper seal |

Changing the Filters

The outdoor and indoor conditions of your area will determine the frequency of filter changes. Temspec recommends that the filters be changed every 3 months as a rule-of-thumb. Note that dirty filters adversely affect the overall performance of the unit.

To change the mixed air and ERV outdoor air (OA) filters, open / remove the filter access panel by loosening the Phillips head screws, unclip the two mixed air filters and remove. If the unit is equipped with an ERV module you can remove and replace the ERV OA filters which is located below the mixed air filters near the back right side of the unit.

Be sure to note the airflow direction that is marked on the filter(s).

To change the ERV exhaust filter remove the return air access panel by loosening the Philips head screws, unclip the ERV exhaust filter located on the on the ERV access panel and replace filter noting the airflow direction on the filter.

Replace all access panels and ensure fasteners are securely fastened.

Waterside Component Maintenance

The following are the recommended steps for performing maintenance on the Hydronic portion of the unit.

CAUTION: Disconnect power at the remote circuit breaker before servicing the unit.

- Clean strainer, check and clean regularly. See the maintenance schedule for suggested frequency.

Cleaning the Evaporator and Hot Water Coils

CAUTION: Disconnect power before servicing the unit.

WARNING: Do NOT use condenser coil cleaning compounds on the evaporator or hot water coils.

To clean the evaporator coil, purchase a suitable evaporator coil cleaning solution such as those offered by NU-CALGON. Follow the manufacturer's instructions for use.

Note: Chlorine based or anti-fungal “pucks” or “socks” are acceptable when **placed in the evaporator drain pan**. Be sure to vacuum the drain pan after the cleaning process is complete and prior to adding the anti-fungal component.

WARNING: Do NOT use chlorine based cleaners or anti-fungal treatments on the aluminum fins of any coil.

Motors

Temspec provides motors that are permanently lubricated. No maintenance is required.

Cleaning the Energy Recovery Wheel

CAUTION: Disconnect power before servicing the unit.

WARNING: Do NOT use ACID based solutions, AROMATIC solvents, STEAM OR WATER with temperatures GREATER than 170°F.

The clean desiccant coated polymer energy recovery wheel you will require a non-acid based (evaporator) coil cleanser or alkaline detergent.

First you must gain access to the energy recovery wheel by removing the return air and ERV access panel by loosening the required fasteners. Once this is completed follow the recommended steps of the wheel manufacturer AirXchange listed below.

- Remove wheel from Heat Pump
- Remove the wheel from the cassette
- Remove loose accumulated dirt by brushing the wheel face
- Wash the wheel with a non-acid based (evaporator) coil cleanser or alkaline detergent solution. (The wheel manufacturer suggest cleaners such as KMP Acti-Clean in a 5% solution works well)
- If the wheel is extremely dirty it may be required to soak overnight to remove all contaminants.
- Once soaking completed, rinse the solution from the wheel until the water comes clear.
- Allow excess water to drain and re-install cassette.

PLEASE NOTE: There may be some staining to the desiccant however this will not adversely affect the performance.

For more information please see the manufacturers' website

<http://www.airxchange.com/resource-center-technical-notes.htm>

Model: ERC 2108 with 2" cassette



TROUBLESHOOTING

Basic Trouble Shooting Guidelines

Problem

- Supply fan not running

Action Required

- Verify that the disconnect is in the “on” position
- Verify that door micro-switch “kill switch” is completely depressed and operating correctly
- Verify that thermostat / controller is not in unoccupied mode (night set-back)
- Check manual reset controls (electric heat, high refrigerant pressure controls and low limit temperature control) and ensure that they have not been tripped.
- Check the fan relay to observe if it is energizing and de-energizing properly
- Check that the 24V transformer is working properly
- Ensure that the wire connections are secured properly

-
- Compressor cycling on and off

- To the condenser air path. Obstructions will cause the unit to cut-out on high head pressure.
- Check refrigerant charge. If the charge is too low, the unit will cut-out on low pressure. The Refrigerant type and amount is posted on the silver CSA label located on the electrical enclosure or fan housing.

REPLACEMENT PARTS

Limited Warranty

TEMSPEC INCORPORATED warrants the equipment from factory defects in material or workmanship for a period of one year.

For this warranty to be valid, the unit(s) must be installed and maintained in accordance with the manufacturer's printed instructions. It does not cover parts damaged by vandalism, improper installation, maintenance or abuse.

Should any replacement parts be required within the warranty period, they will be supplied at no charge, freight prepaid to the jobsite. The cost of labor or incidental expenses incurred in the repair or replacement of parts does not form part of this warranty.

The warranty period commences from the date of shipment, except when otherwise agreed at the point of sale (see specific warranty terms and conditions for details).

Parts Sales

Contact the factory at: 1-888-TEMSPEC or (905) 670-3595

sales@temspec.com

Ask for 'parts sales'

Be sure to provide the unit serial number which is located on the metalized CSA label, on the fan housing, inside the units.