

Operation & Maintenance Manual

Unit Ventilators



IMPORTANT: Read and save this manual for future reference.
This manual is to be left with the equipment owner

INTRODUCTION.....	2
About the Unit Ventilator	2
NOMENCLATURE FOR NON-COMPRESSORIZED UNIT VENTILATORS.....	2
SAFETY WARNINGS	3
ELECTRICAL CONNECTIONS.....	4
Line Voltage Connections	4
Type and Ratings of Fuses and Circuit Breakers	4
Grounding.....	4
Low Voltage Connections	4
TYPICAL LAYOUTS	5
VUD 1200	5
VUD 1600	6
VUD 2000	7
VUF 1200	8
VUF 1500	9
VDF 1200	10
HCD 1200.....	11
HCD 1600.....	12
VER 1800	13
VGB 1600.....	14
HGB 1600.....	15
VUD Face and Bypass.....	16
OPERATION	17
Typical Modes of Operation	17
Standard Piping.....	18
Dampers	23
Powered Exhaust	23
Filtration.....	23
VER ERW Balancing Procedure	24
VGB Outdoor Air Balancing Procedure.....	25
MAINTENANCE	27
Servicing the Unit	27
Maintenance Schedule.....	27
Changing the Filters	27
Cleaning the Coils	28
Motors.....	28
Cleaning the Energy Recovery Wheel.....	28
Duct Attenuation.....	30
Maximum Operating Conditions	30
TROUBLESHOOTING	31
Accessories Instructions	32
Block-off Panel	32
Side Pipe Cover	33
Top Extension	34
Top Plenum – Direct Supply	35
Top Acoustical Plenum	36
Raised Base	37
Rear Plenum.....	38
Wall Assembly.....	40
UVC Light.....	41
REPLACEMENT PARTS	42
Limited Warranty	42
Part Sales	42



INTRODUCTION

About the Unit Ventilator

The Temspec unit ventilator is designed as a means for providing heating, cooling, and ventilation to the classroom. Our goal is to help create an enhanced learning environment by focusing on the following points when designing our equipment:

- Cooling, Heating, Humidity And Ventilation Control
- Air Distribution
- Sound Attenuation

By installing the vertical unit ventilator into the classroom, superior control can be obtained for each room. Because the unit can be ducted, an even distribution of air can be achieved throughout the room. The unit ventilator is constructed with heavy gauge metal and sound absorbing insulation for optimal sound attenuation.

By applying sound engineering principles and thorough testing, we ensure the highest quality of performance of our unit ventilators.

NOMENCLATURE FOR NON-COMPRESSORIZED UNIT VENTILATORS

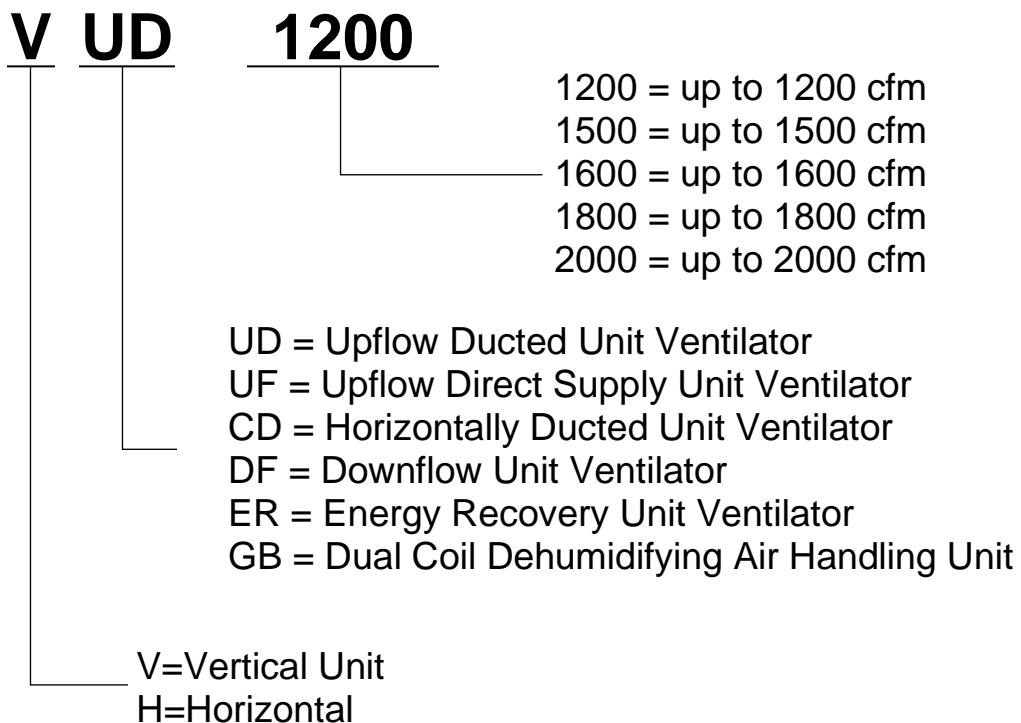

SAFETY WARNINGS

Read the manual thoroughly before installing and using the appliance. This will ensure the best results and maximum safety.

WARNING

ELECTRICAL SHOCK HAZARD

Failure to follow this warning could result in personal injury or death. Field wires on the line side of the disconnect located inside the unit remain live, even when the disconnect switch is off. Service and maintenance to incoming wiring cannot be performed until the main remote disconnect is turned off, locked out and tagged.

This appliance is not intended for use by persons (including children) with reduced physical, sensory or mental capabilities, or lack of experience and knowledge, unless they have been given supervision or instruction concerning use of the appliance by a person responsible for their safety.

“Children should be supervised to ensure that they do not play with the appliance.”

WARNING

This appliance may contain UV-C LEDs

DO NOT OPERATE UV-C LAMPS OUTSIDE THE APPLIANCE



UV Light Hazard. Harmful to skin and eyes. Can cause temporary or permanent loss of vision. Never look at the lamp while illuminated. To prevent exposure to ultraviolet light, be sure the power is disconnected before servicing.

DO NOT touch UVC LEDs with bare hands

CAUTION

This appliance may contain an Ionizer

Ionizer generates high voltage. Make sure power is disconnected before cleaning the ionizer brush heads.

Remove any accumulated dirt on the ionizer brush heads to prevent risk of flashover or fire.



ELECTRICAL CONNECTIONS

Use Copper Supply Wires Only

Use Supply Wires Suitable for 90°C

Our unit Ventilators are available in the following voltages: 120/1/60, 208/1/60, 240/1/60, 277/1/60, 208/3/60, 480/3/60, 480/3/60 + N

The electrical circuit in the unit ventilator is highly dependent on the controller and control sequence that is being utilized. A copy of the electrical schematic can be found folded in a pouch inside of the unit ventilator or in the final job submittal.

Access to power is through the top of the unit (unless ordered differently). The unit has a single point connection at the junction box (comes with disconnect switch) located inside the unit either above or below the electrical box. Junction box may be located on the rebate inside the unit if the electrical enclosure is door mounted. A circuit breaker may be used instead of the disconnect depending on the amperage.

The electrical wiring must be in accordance with the current applicable national and local codes. A qualified electrician must carry out the work. The electrical power to the unit should be disconnected by opening the remote disconnect device prior to opening the access panel. The wiring diagram shall be followed thoroughly when making connections to the unit.

A conduit is to be field installed in the unit such that hazardous voltage wiring is protected until it is terminated. In the junction box or electrical enclosure.

Line Voltage Connections

Connect power leads from the field disconnect to the pigtails provided with the disconnect at the junction box located inside the appliance and ground at the green screw located inside the junction box.

If a circuit breaker is used, terminate the field provided line leads directly at the circuit breaker. The neutral line to be terminated at the power distribution block and ground at the lug located beside the circuit breaker inside the electrical enclosure.

Type and Ratings of Fuses and Circuit Breakers

Up to 30A time delay fuses are used. Up to 3 pole 100A circuit breakers are used.

Grounding

The Unit Ventilator must be grounded for field connections wires up to #10 AWG using the green ground screw inside the junction box. If the field connection wires are larger than # 10 AWG, the grounding point is a ground lug installed in the electrical enclosure.

Low Voltage Connections

There is a sheet metal barrier between line voltage and extra low voltage circuits inside the electrical enclosure. Low voltage connections are to be made to the terminal block or a controller mounted on the low voltage side of the electrical enclosure. The unit is equipped with 1/2 inch flex metal conduit to segregate wires entering unit. A conduit termination port is provided on the electrical enclosure.

TYPICAL LAYOUTS

VUD 1200

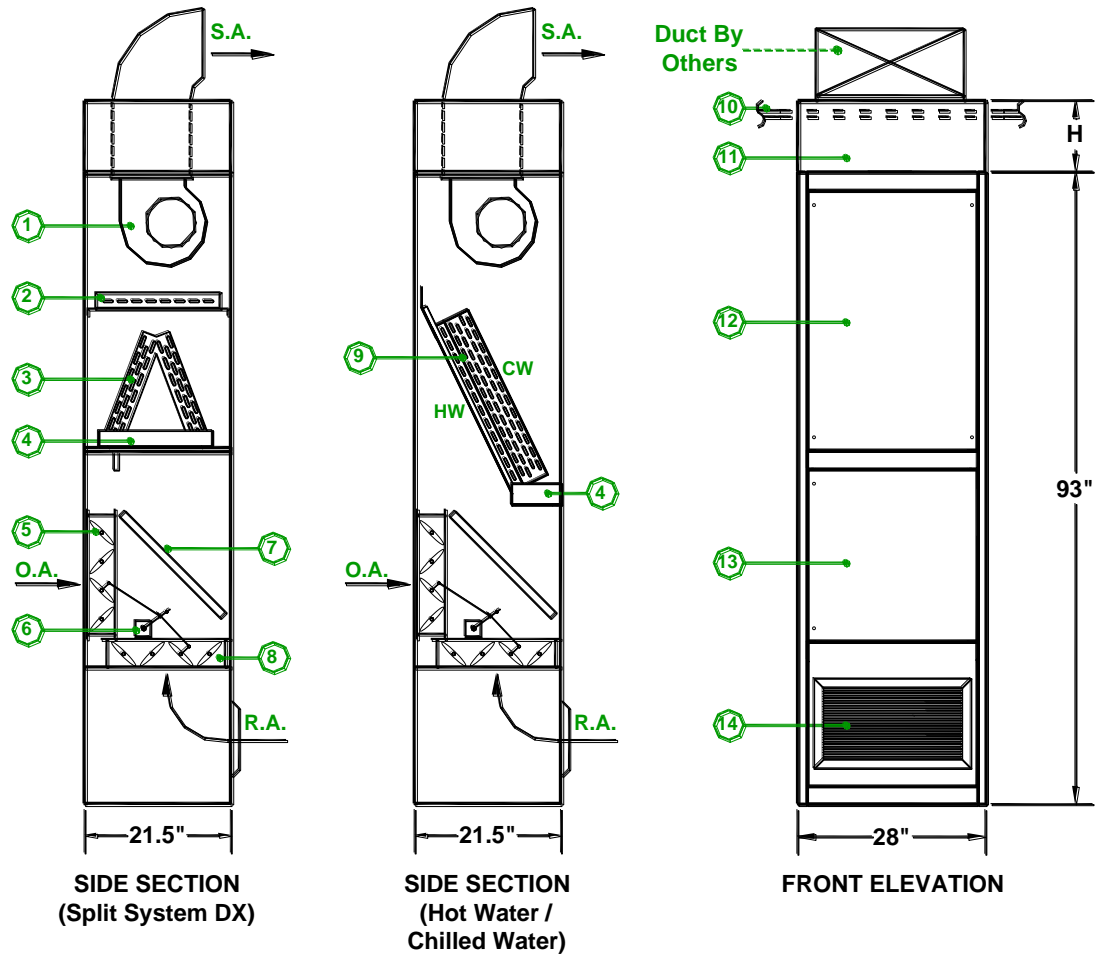

S.A. Supply Air **O.A.** Outdoor Air **R.A.** Return Air

- | | |
|-----------------------------------------------------------------------------------------------------------------------------------------------------------------------------------------------------------------------------------------------------------------------------------------------------------|--------------------------------------------------------------------------------------------------------------------------------------------------------------------------------------------------------------------------------------------------------------------------------------------------------------------------------------------|
| <ul style="list-style-type: none"> 1. Supply air fan. 2. Hot water coil. Optional electric or steam coil available. 3. DX cooling coil. 4. Drain pan. 5. Outdoor air damper. 6. Spring return mixed air damper actuator. 7. Filters. | <ul style="list-style-type: none"> 8. Return air damper. 9. 2 pipe or 4 pipe (hot water coil can be in the reheat position). 10. Ceiling tile. 11. Top extension (optional). 12. Coil access panel. 13. Hinged filter access panel. 14. Heavy duty return air grille. |
|-----------------------------------------------------------------------------------------------------------------------------------------------------------------------------------------------------------------------------------------------------------------------------------------------------------|--------------------------------------------------------------------------------------------------------------------------------------------------------------------------------------------------------------------------------------------------------------------------------------------------------------------------------------------|

NOTE: The component arrangement shown above may vary slightly from that in the unit supplied.

VUD 1600

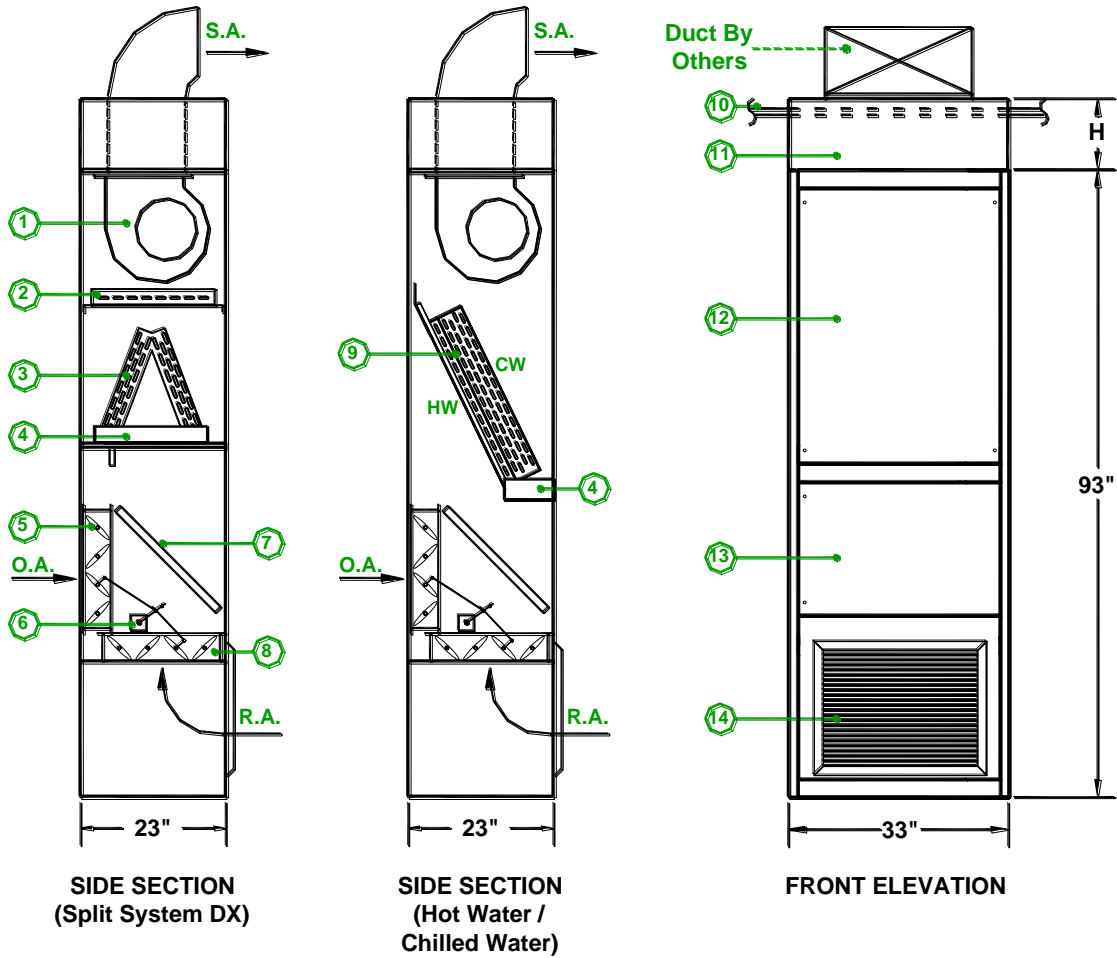

S.A. Supply Air **O.A.** Outdoor Air **R.A.** Return Air

- | | |
|-----------------------------------------------------------------------------------------------------------------------------------------------------------------------------------------------------------------------------------------------------------------------------------------------------------|--------------------------------------------------------------------------------------------------------------------------------------------------------------------------------------------------------------------------------------------------------------------------------------------------------------------------------------------|
| <ul style="list-style-type: none"> 1. Supply air fan. 2. Hot water coil. Optional electric or steam coil available. 3. DX cooling coil. 4. Drain pan. 5. Outdoor air damper. 6. Spring return mixed air damper actuator. 7. Filters. | <ul style="list-style-type: none"> 8. Return air damper. 9. 2 pipe or 4 pipe (hot water coil can be in the reheat position). 10. Ceiling tile. 11. Top extension (optional). 12. Coil access panel. 13. Hinged filter access panel. 14. Heavy duty return air grille. |
|-----------------------------------------------------------------------------------------------------------------------------------------------------------------------------------------------------------------------------------------------------------------------------------------------------------|--------------------------------------------------------------------------------------------------------------------------------------------------------------------------------------------------------------------------------------------------------------------------------------------------------------------------------------------|

NOTE: The component arrangement shown above may vary slightly from that in the unit supplied.

VUD 2000

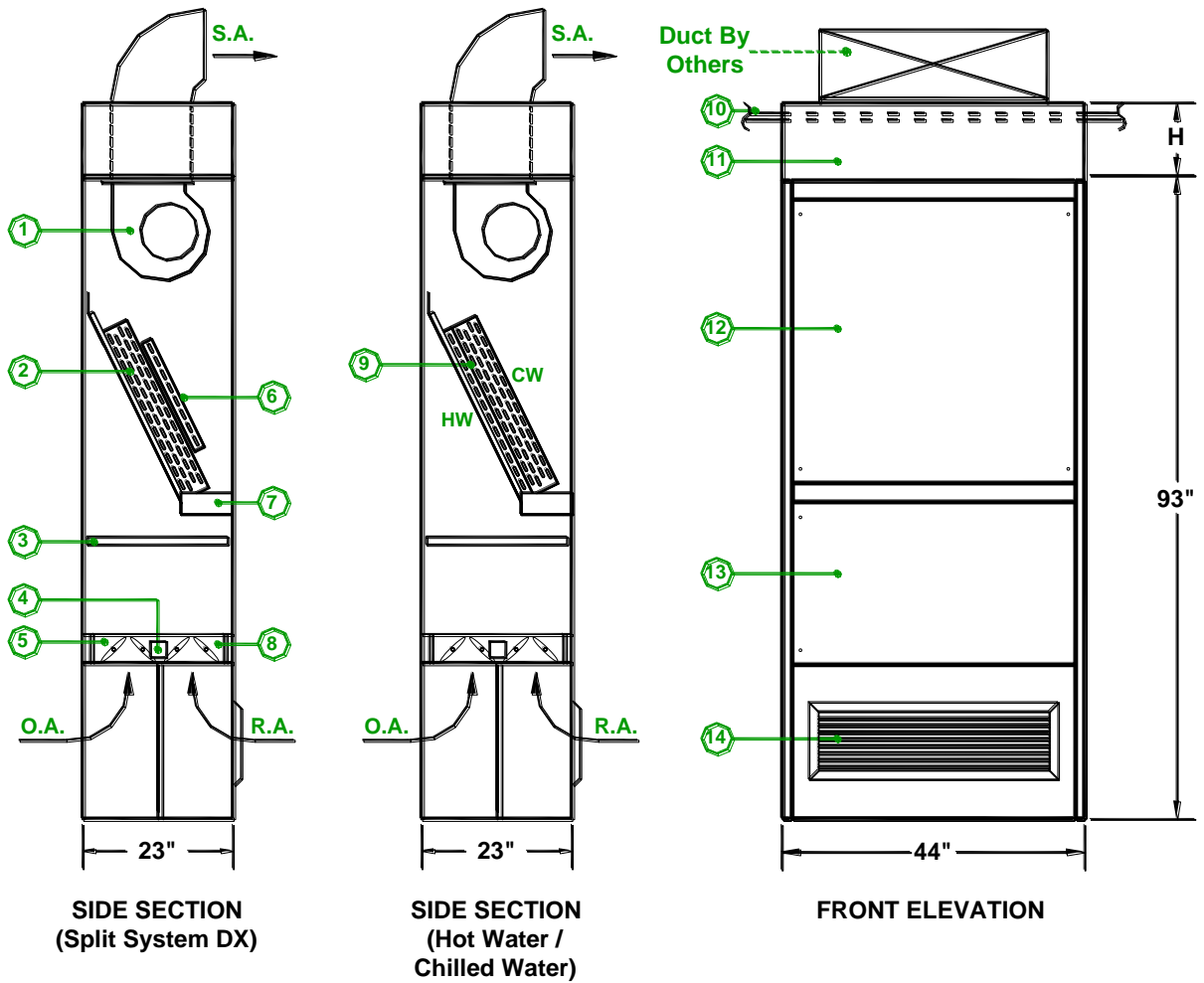

S.A. Supply Air **O.A.** Outdoor Air **R.A.** Return Air

- 1. Dual supply air fans.
- 2. DX cooling coil.
- 3. Filters.
- 4. Spring return mixed air damper actuator.
- 5. Outdoor air damper.
- 6. Hot water coil. Optional electric or steam coil available.
- 7. Drain pan.
- 8. Return air damper.
- 9. 2 pipe or 4 pipe (hot water coil can be in the reheat position).
- 10. Ceiling tile.
- 11. Top extension (optional).
- 12. Coil access panel.
- 13. Hinged filter access panel.
- 14. Heavy duty return air grille.

NOTE: The component arrangement shown above may vary slightly from that in the unit supplied.

VUF 1200

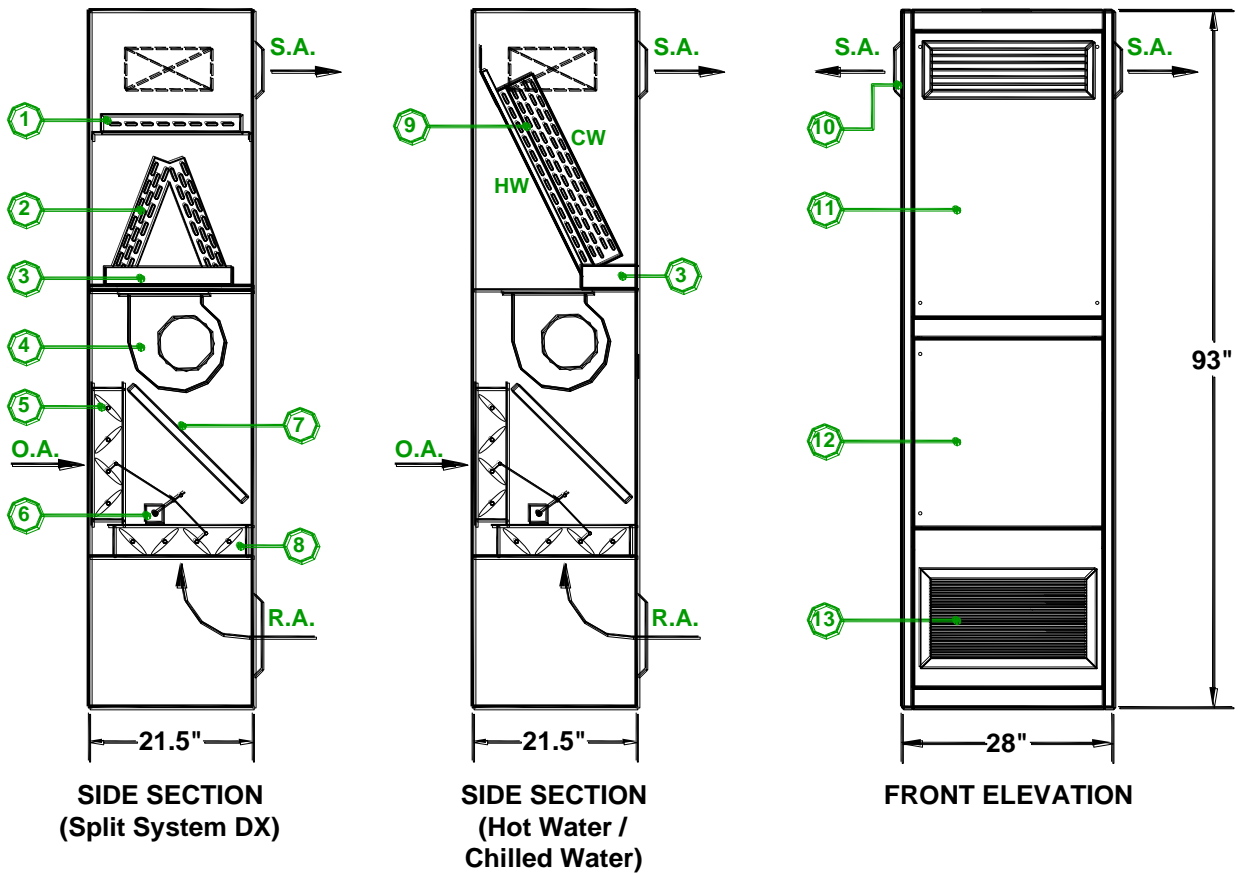

S.A. Supply Air **O.A.** Outdoor Air **R.A.** Return Air

- | | |
|-----------------------------------------------------------------------------------------------------------------------------------------------------------------------------------------------------------------------------------------------------------------------------------------------------------|----------------------------------------------------------------------------------------------------------------------------------------------------------------------------------------------------------------------------------------------------------------------------------------------------------------------------|
| <ul style="list-style-type: none"> 1. Hot water coil. Optional electric or steam coil available. 2. DX cooling coil. 3. Drain pan. 4. Supply air fan. 5. Outdoor air damper. 6. Spring return mixed air damper actuator. 7. Filters. | <ul style="list-style-type: none"> 8. Return air damper. 9. 2 pipe or 4 pipe (hot water coil can be in the reheat position). 10. Double deflection supply air grille. 11. Coil access panel. 12. Hinged filter access panel. 13. Heavy duty return air grille. |
|-----------------------------------------------------------------------------------------------------------------------------------------------------------------------------------------------------------------------------------------------------------------------------------------------------------|----------------------------------------------------------------------------------------------------------------------------------------------------------------------------------------------------------------------------------------------------------------------------------------------------------------------------|

NOTE: The component arrangement shown above may vary slightly from that in the unit supplied.

VUF 1500

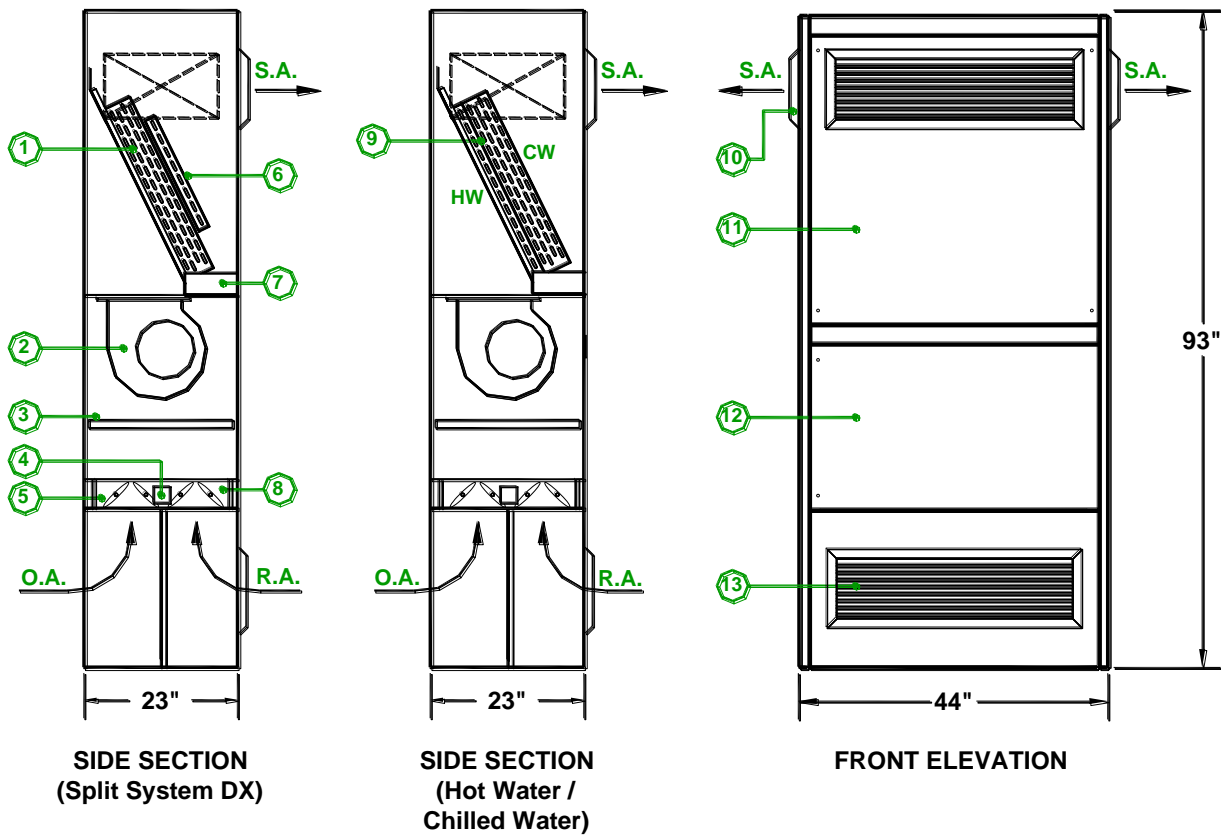

S.A. Supply Air **O.A.** Outdoor Air **R.A.** Return Air

- | | |
|-----------------------------------------------------------------------------------------------------------------------------------------------------------------------------------------------------------------------------------------------------------------------------------------------------------------|------------------------------------------------------------------------------------------------------------------------------------------------------------------------------------------------------------------------------------------------------------------------------------------------------------------|
| <ul style="list-style-type: none"> 1. DX cooling coil. 2. Dual supply air fans. 3. Filters. 4. Spring return mixed air damper actuator. 5. Outdoor air damper. 6. Hot water coil. Optional electric or steam coil available. 7. Drain pan. | <ul style="list-style-type: none"> 8. Return air damper. 9. 2 pipe or 4 pipe (hot water coil can be in the reheat position). 10. Double deflection grilles. 11. Coil access panel. 12. Hinged filter access panel. 13. Heavy duty return air grille. |
|-----------------------------------------------------------------------------------------------------------------------------------------------------------------------------------------------------------------------------------------------------------------------------------------------------------------|------------------------------------------------------------------------------------------------------------------------------------------------------------------------------------------------------------------------------------------------------------------------------------------------------------------|

NOTE: The component arrangement shown above may vary slightly from that in the unit supplied.

VDF 1200

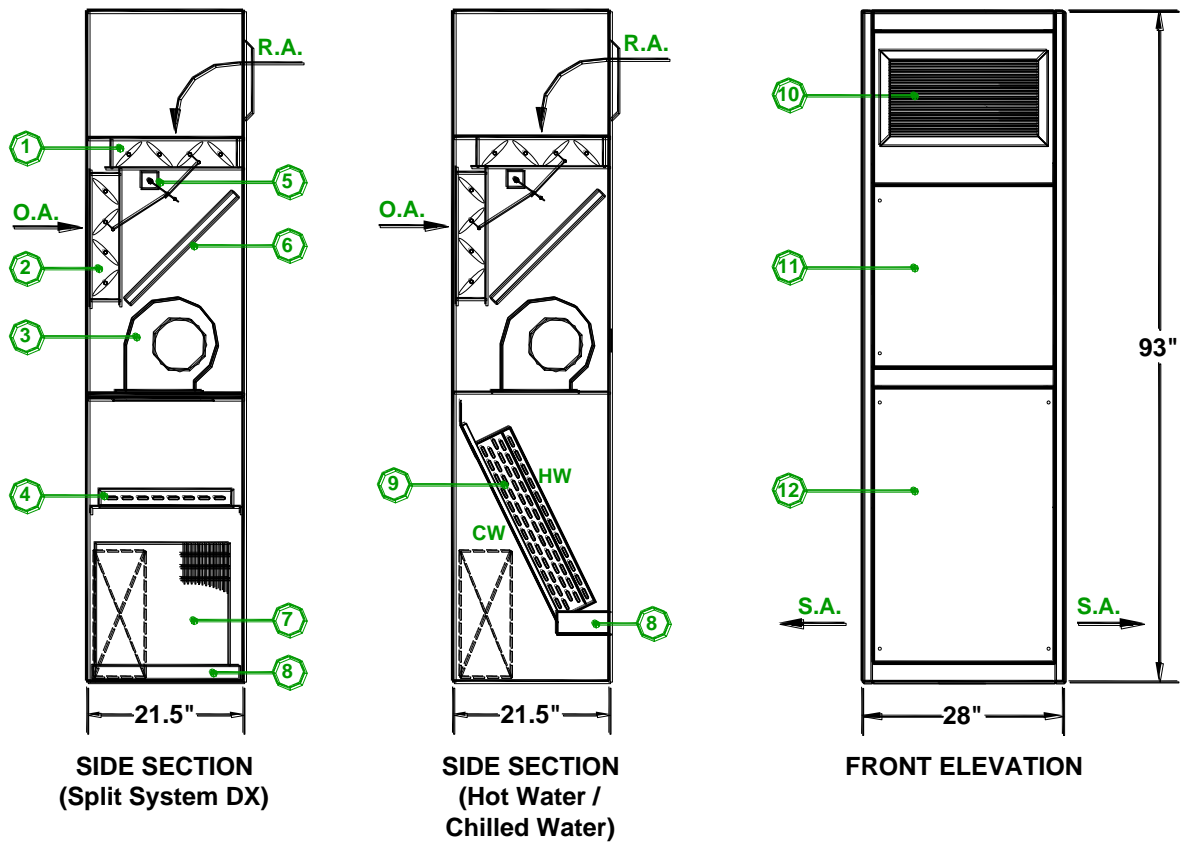

S.A. Supply Air **O.A.** Outdoor Air **R.A.** Return Air

- 1. Return Air damper.
- 2. Outdoor air damper.
- 3. Supply air fan.
- 4. Hot water coil. Optional electric or steam coil available.
- 5. Spring return mixed air damper actuator.
- 6. Filters.
- 7. Slab type DX cooling coil.
- 8. Drain pan.
- 9. 2 pipe or 4 pipe (hot water coil can be in the reheat position).
- 10. Heavy duty return air grille.
- 11. Hinged filter access panel.
- 12. Coil access panel.

NOTE: The component arrangement shown above may vary slightly from that in the unit supplied.

HCD 1200

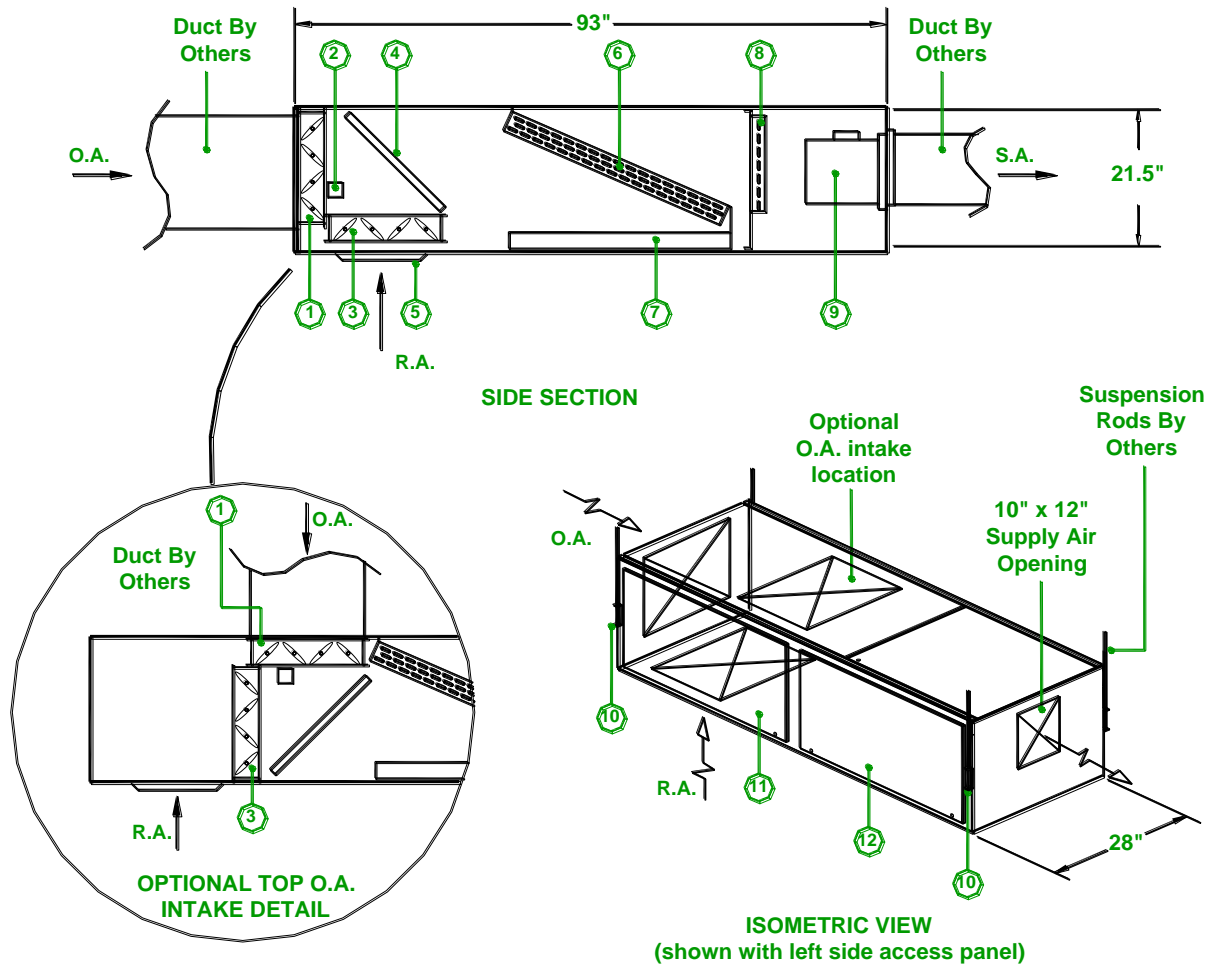

S.A. Supply Air O.A. Outdoor Air R.A. Return Air

- | | |
|---------------------------------------------------------------------------------------------------------------------------------------------------------------------------------------------------------------------------------------------------------------------------------------------------------------------------------------------------------------------------------------------------------------------|--------------------------------------------------------------------------------------------------------------------------------------------------------------------------------------------------------------------------------------------------------------------------------------------------------------------------------------------------------------------------------------------------------------------------------------------------------|
| <ul style="list-style-type: none"> 1. Outdoor air damper. 2. Spring return mixed air damper actuator. 3. Return air damper. 4. Filters. 5. Heavy duty return air grille or duct collar. 6. Split DX or hot water/chilled water coil (2 pipe or 4 pipe). 7. Drain pan. Drain pan is removable when option for bottom access panels is selected. | <ul style="list-style-type: none"> 8. Hot water coil for split system DX or heating only units. Optional steam and electric heater also available. 9. Supply air fan. 10. Mounting brackets (4 per unit). 11. Left or Right side hinged filter access panel. Bottom hinged access panel also available. 12. Left or Right side hinged coil access panel. Bottom hinged access panel also available. |
|---------------------------------------------------------------------------------------------------------------------------------------------------------------------------------------------------------------------------------------------------------------------------------------------------------------------------------------------------------------------------------------------------------------------|--------------------------------------------------------------------------------------------------------------------------------------------------------------------------------------------------------------------------------------------------------------------------------------------------------------------------------------------------------------------------------------------------------------------------------------------------------|

NOTE: The component arrangement shown above may vary slightly from that in the unit supplied.

HCD 1600

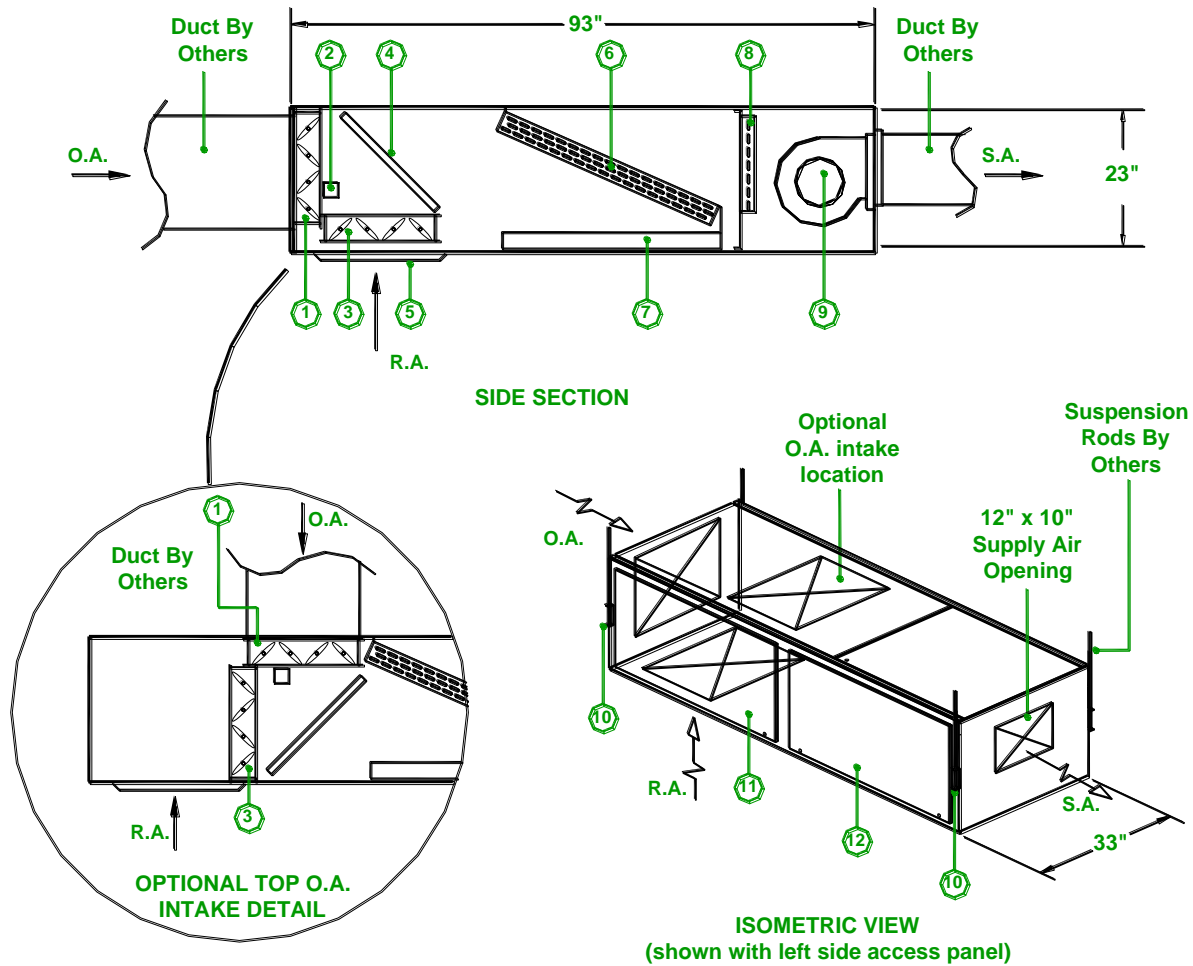

S.A. Supply Air O.A. Outdoor Air R.A. Return Air

- | | |
|---------------------------------------------------------------------------------------------------------------------------------------------------------------------------------------------------------------------------------------------------------------------------------------------------------------------------------------------------------------------------------------------------------------------|--------------------------------------------------------------------------------------------------------------------------------------------------------------------------------------------------------------------------------------------------------------------------------------------------------------------------------------------------------------------------------------------------------------------------------------------------------|
| <ol style="list-style-type: none"> 1. Outdoor air damper. 2. Spring return mixed air damper actuator. 3. Return air damper. 4. Filters. 5. Heavy duty return air grille or duct collar. 6. Split DX or hot water/chilled water coil (2 pipe or 4 pipe). 7. Drain pan. Drain pan is removable when option for bottom access panels is selected. | <ol style="list-style-type: none"> 8. Hot water coil for split system DX or heating only units. Optional steam and electric heater also available. 9. Supply air fan. 10. Mounting brackets (4 per unit). 11. Left or Right side hinged filter access panel. Bottom hinged access panel also available. 12. Left or Right side hinged coil access panel. Bottom hinged access panel also available. |
|---------------------------------------------------------------------------------------------------------------------------------------------------------------------------------------------------------------------------------------------------------------------------------------------------------------------------------------------------------------------------------------------------------------------|--------------------------------------------------------------------------------------------------------------------------------------------------------------------------------------------------------------------------------------------------------------------------------------------------------------------------------------------------------------------------------------------------------------------------------------------------------|

NOTE: The component arrangement shown above may vary slightly from that in the unit supplied.

VER 1800

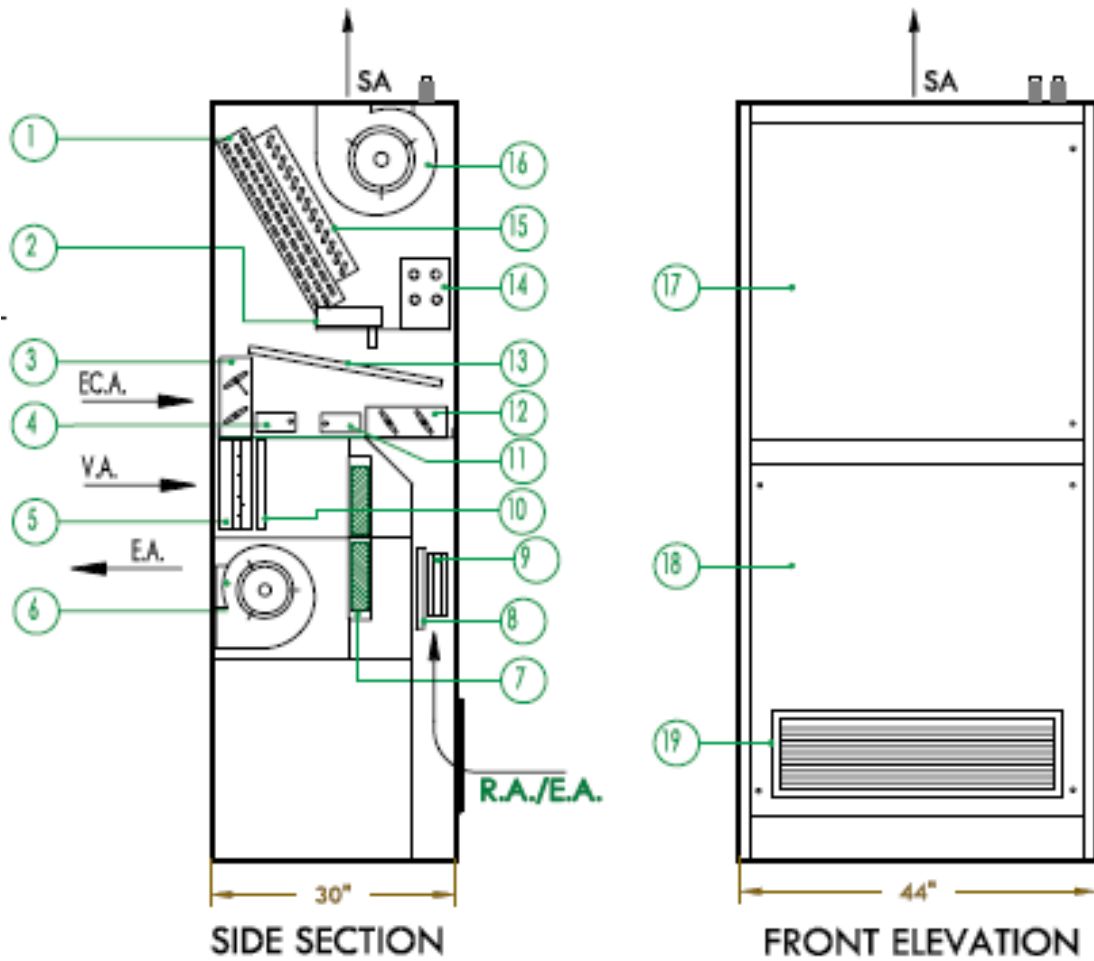

SA = Supply Air
RA = Return Air

VA = Ventilation Air
EA = Exhaust Air

ECA = Economizer Air

ITEM NO.	DESCRIPTION	ITEM NO.	DESCRIPTION	ITEM NO.	DESCRIPTION
1.	Evaporator Coil	8.	ERV Exhaust Filter	15.	Hot Water Coil
2.	Drain Pan	9.	Powered Exhaust Damper and Actuator	16.	Supply Air Fan
3.	100% Economizer OA Damper	10.	ERV O.A. Filter	17.	LH Hinged Access Panel
4.	Modulating damper actuator.	11.	RA Actuator	18.	Removable Access Panel
5.	ERV Damper with Actuator.	12.	RA Damper	19.	Heavy Duty RA Grille
6.	ERV Exhaust Fan	13.	Mixed Air Filters		
7.	ERV Enthalpy Wheel	14.	Electrical Box/Controls Enclosure		

NOTE: The component arrangement shown above may vary slightly from that in the unit supplied

VGB 1600

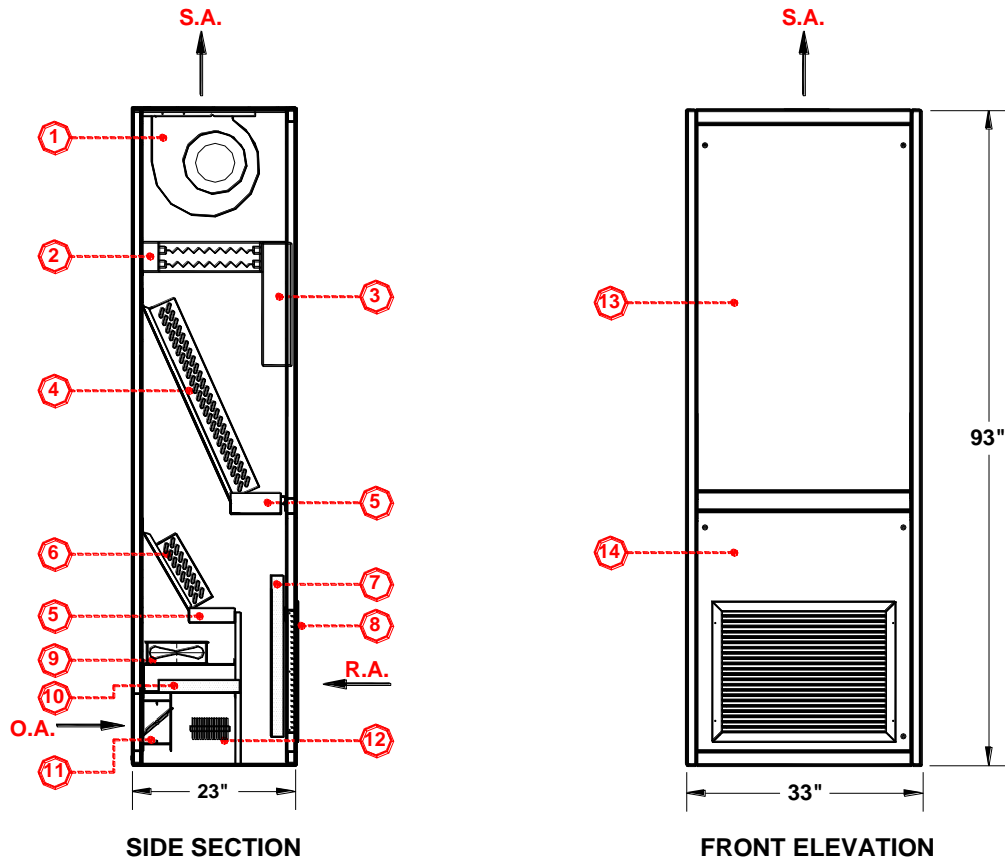

S.A. Supply Air O.A. Outdoor Air R.A. Return Air

- | | |
|----------------------------------------------------------------------------------------------------------------------------------------------------------------------------------------------------------------------------------------------------------------------------------------------------------------|-----------------------------------------------------------------------------------------------------------------------------------------------------------------------------------------------------------------------------------------------------------------------------------------------------------|
| <ul style="list-style-type: none"> 1. Supply air fan. 2. Optional electric coil. 3. Control / electrical enclosure. 4. Primary coil (DX or chilled water). 5. Drain pan. 6. Outdoor air coil (DX or chilled water). 7. Return air filter. | <ul style="list-style-type: none"> 8. Heavy duty return air grille. 9. Outdoor air fan. 10. Outdoor air filter. 11. Outdoor air damper. 12. Optional electric freeze protection. 13. Coil access panel. 14. Return air access panel. |
|----------------------------------------------------------------------------------------------------------------------------------------------------------------------------------------------------------------------------------------------------------------------------------------------------------------|-----------------------------------------------------------------------------------------------------------------------------------------------------------------------------------------------------------------------------------------------------------------------------------------------------------|

Note: The component arrangement shown above may vary slightly from that in the unit supplied

HGB 1600

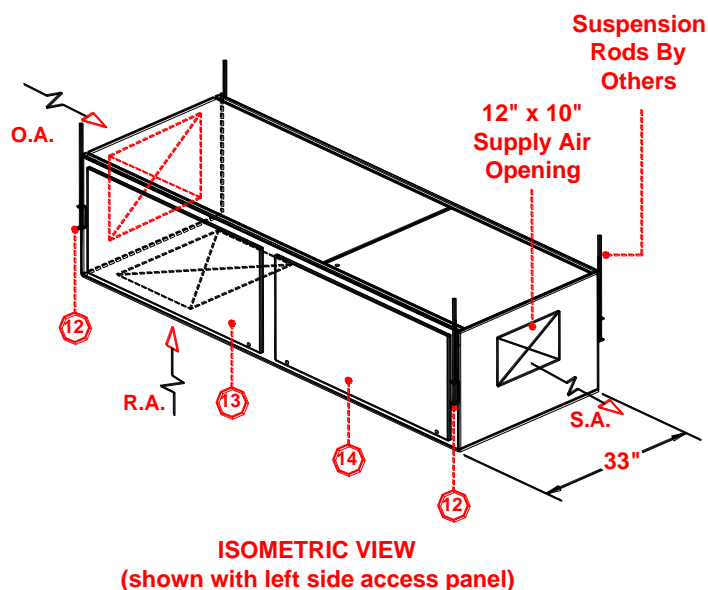
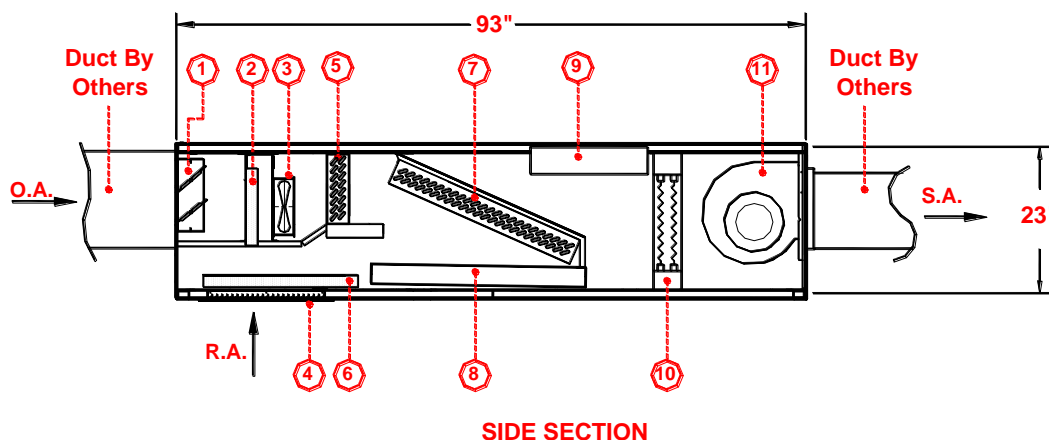

S.A. Supply Air O.A. Outdoor Air R.A. Return Air

- | | |
|-------------------------------------------------------------------------------------------------------------------------------------------------------------------------------------------------------------------------------------------------------------------------------------------------------------------------------|-----------------------------------------------------------------------------------------------------------------------------------------------------------------------------------------------------------------------------------------------------------------------------------------------------------------------------------------------------------------------------------------------------------------------------|
| <ul style="list-style-type: none"> 1. Outdoor air damper. 2. Outdoor air filter. 3. Outdoor air fan. 4. Heavy duty return air grille or duct collar. 5. Outdoor air chilled water or DX coil. 6. Return air filter. 7. Primary chilled water or DX coil. | <ul style="list-style-type: none"> 8. Drain pan. Drain pan is removable when option for bottom access panels is selected. 9. Electrical / control enclosure. 10. Optional Electric heater. 11. Supply air fan. 12. Mounting brackets (4 per unit). 13. Left or Right side hinged filter access panel. 14. Left or Right side hinged coil access panel. |
|-------------------------------------------------------------------------------------------------------------------------------------------------------------------------------------------------------------------------------------------------------------------------------------------------------------------------------|-----------------------------------------------------------------------------------------------------------------------------------------------------------------------------------------------------------------------------------------------------------------------------------------------------------------------------------------------------------------------------------------------------------------------------|

Note: The component arrangement shown above may vary slightly from that in the unit supplied

VUD Face and Bypass

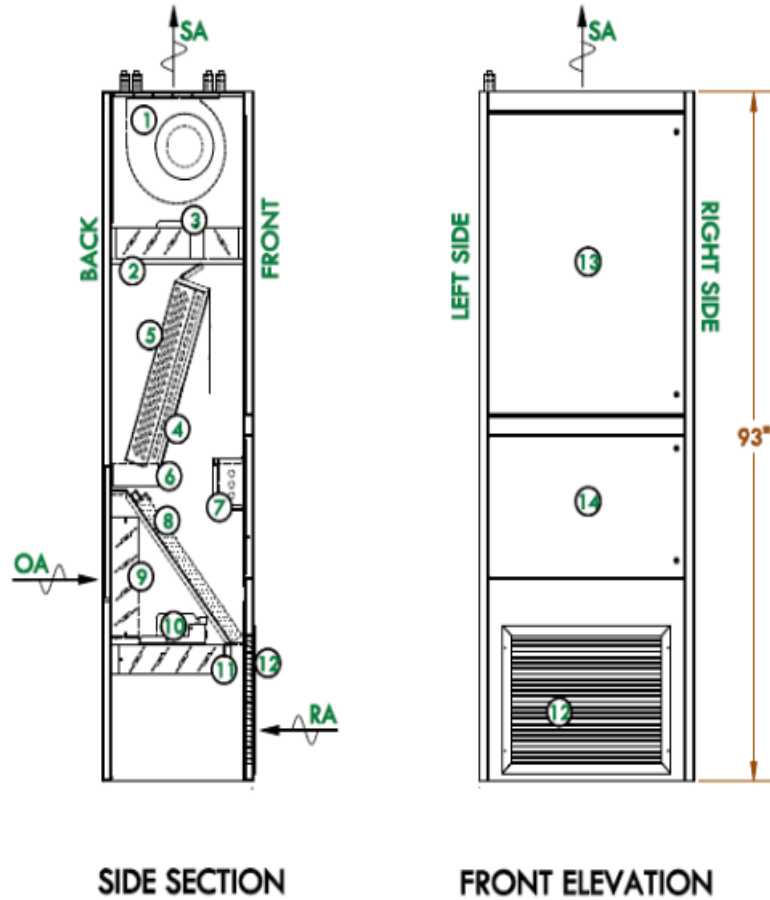

- 1. Supply air fan.
- 2. Face & bypass control dampers.
- 3. Face & bypass damper actuator.
- 4. Hot water coil.
- 5. Chilled water coil.
- 6. Drain pan.
- 7. Electrical / control enclosure.

- 8. Mixed air filters.
- 9. Outdoor air damper.
- 10. Mix air damper actuator.
- 11. Return air damper.
- 12. Heavy duty steel return air grille, painted.
- 13. Coil access panel, hinged.
- 14. Filter access panel, hinged.

Note: The component arrangement shown above may vary slightly from that in the unit supplied
Note: The cabinet size remains the same for Face and Bypass control or Valve control units

OPERATION

Typical Modes of Operation

The following are typical modes of operation for a classroom unit ventilator. Please refer to the manual provided by the control's contractor for a more specific controls sequence.

Unoccupied Heating/Cooling

During Unoccupied heating/ cooling the outdoor air damper, wheel air damper (if applicable) and powered exhaust damper (if applicable) are fully closed. The powered exhaust fan (if applicable) and energy recovery wheel (if applicable) are off. The space is maintained at a setback temperature by modulating the control valve actuator or face and bypass damper actuator or outdoor condensing unit or electric heat as needed. The supply fan should only run when heating or cooling is required.

Occupied Heating/ Cooling

During Occupied heating/ cooling for standard Unit Ventilators (VUD, VUF, VDF, HCD) the outdoor air damper will modulate to the minimum required position. If the unit has powered exhaust, the powered exhaust damper will open, and the powered exhaust fan will turn on. The space temperature is maintained by modulating the control valve actuator or face and bypass damper actuator or outdoor condensing unit or electric heat as needed. The supply fan will run at all times.

If the unit is equipped with an Energy Recovery Wheel (VER), the wheel air damper will open, the wheel will start spinning and the powered exhaust fan will start. The economizer damper will remain closed. The space temperature is maintained by modulating the control valve actuator or electric heat as needed. The supply fan will run at all times.

Economizer (up to 100% outdoor air)

Economizer mode is activated when the controller compares the Outdoor Air Enthalpy to the Mixed Air Temperature and determines that the outdoor air is cool and dry enough to properly cool the space. During this mode the outdoor air damper and return air damper will modulate to maintain the space temperature.

If the unit is equipped with an Energy Recover Wheel, the wheel will stop, and the wheel air damper will close. When the economizer damper opens, the exhaust air damper will open, and the powered exhaust fan will run at high speed for 100% powered exhaust operation.

Dehumidifying Mode (VGB/HGB Series)

During occupied cooling, the Dehumidifying AHU can enter a dehumidifying mode. In this mode (normally when the outdoor air is above 55°F) water is diverted to the outdoor coil to cool and remove moisture from the entering outdoor air.

Freeze Protection

For units with a water coil, some type of freeze protection is usually implemented. This can be by either a low limit temperature control (auto reset or manual reset) or by using an air sensor and programming from the controller. When the mixed air temperature is determined to be too low, then the outdoor air damper will close, and the control valve will fully open. In some cases, the fan will also shut down until the temperature returns to normal levels. The standard hot water actuator is fail open.

Standard Piping

The following are typical hot water piping schematics for a unit ventilator. Please refer to the Job Submittal for a more specific layout.

Hot Water / Chilled Water with 2-way Control

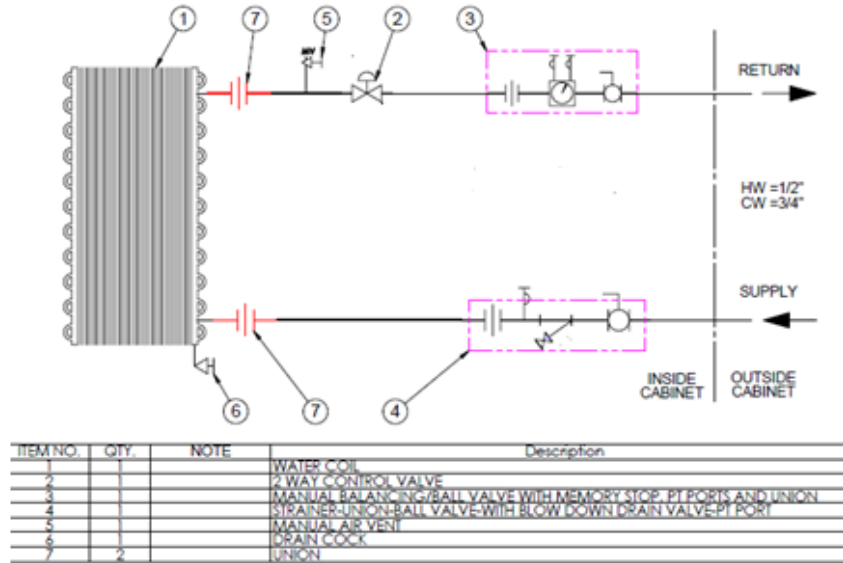

Note: The component arrangement shown above may vary slightly from that in the unit supplied

Hot Water / Chilled Water with 3-way Control

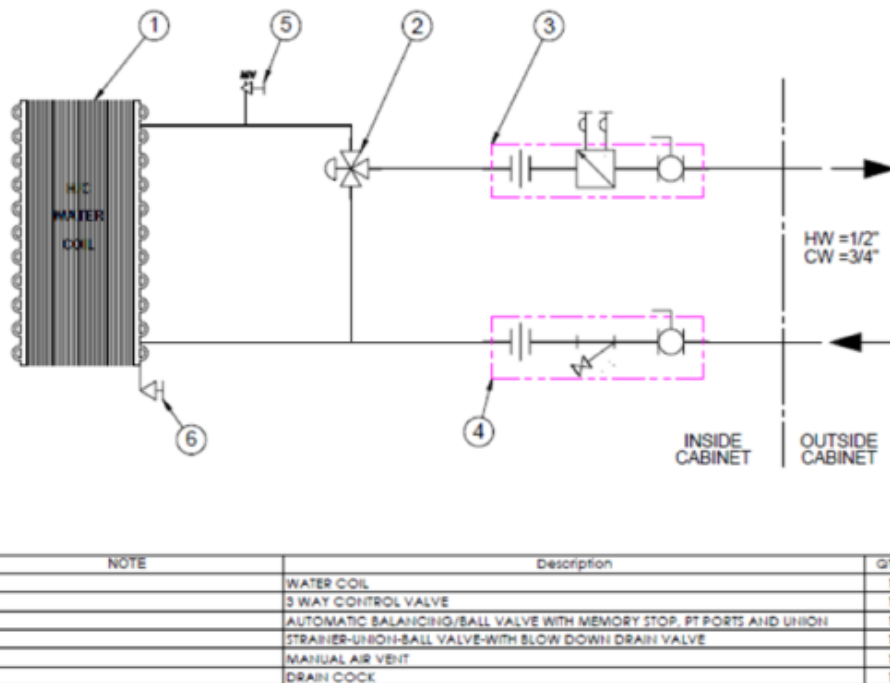

Note: The component arrangement shown above may vary slightly from that in the unit supplied

Hot Water with Reheat Configuration

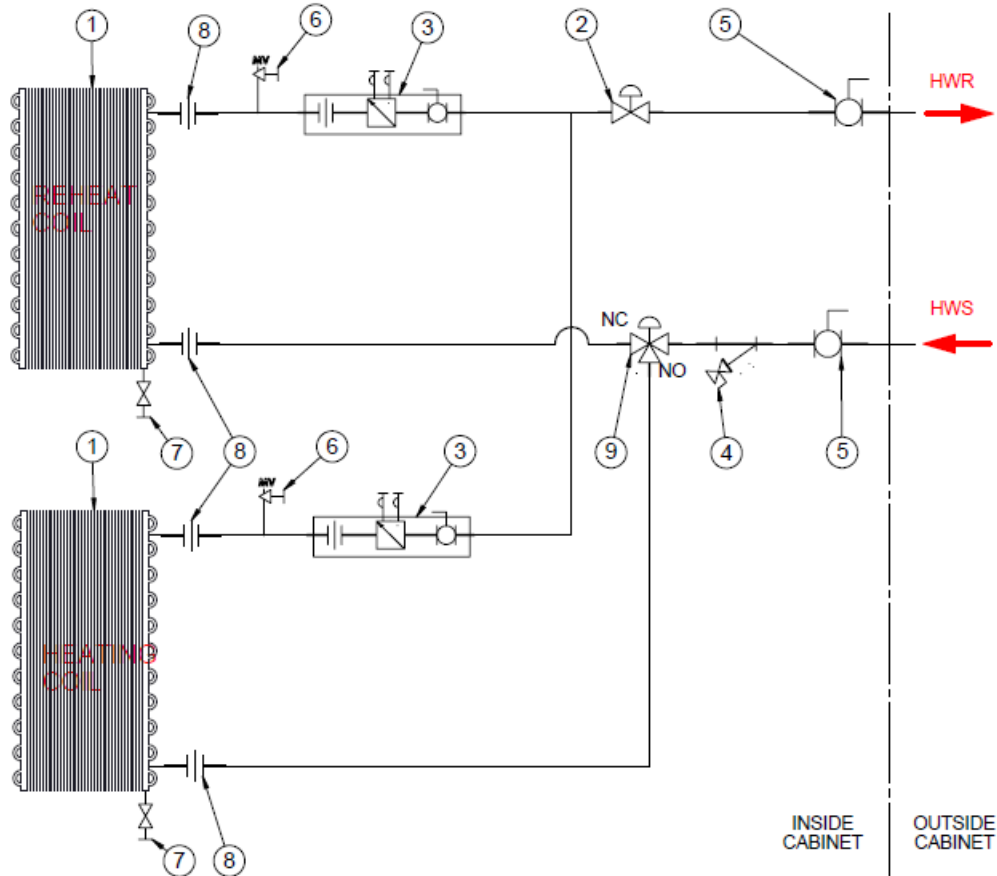

NOTE: ALL ITEMS SHOWN ARE SUPPLIED AND INSTALLED BY TEMSPEC.

ITEM NO.	NOTE	Description	QTY.
1		WATER COIL	1
2		2 WAY CONTROL VALVE	1
3		AUTOMATIC BALANCING/BALL VALVE WITH MEMORY STOP, PT PORTS AND UNION	2
4		STRAINER WITH BLOW DOWN VALVE	1
5		BALL VALVE	2
6		MANUAL AIR VENT	2
7		DRAIN VALVE	2
8		UNION	4
9		3 WAY CONTROL VALVE	1

Note: The component arrangement shown above may vary slightly from that in the unit supplied

VGB Dual Coil Piping Configuration

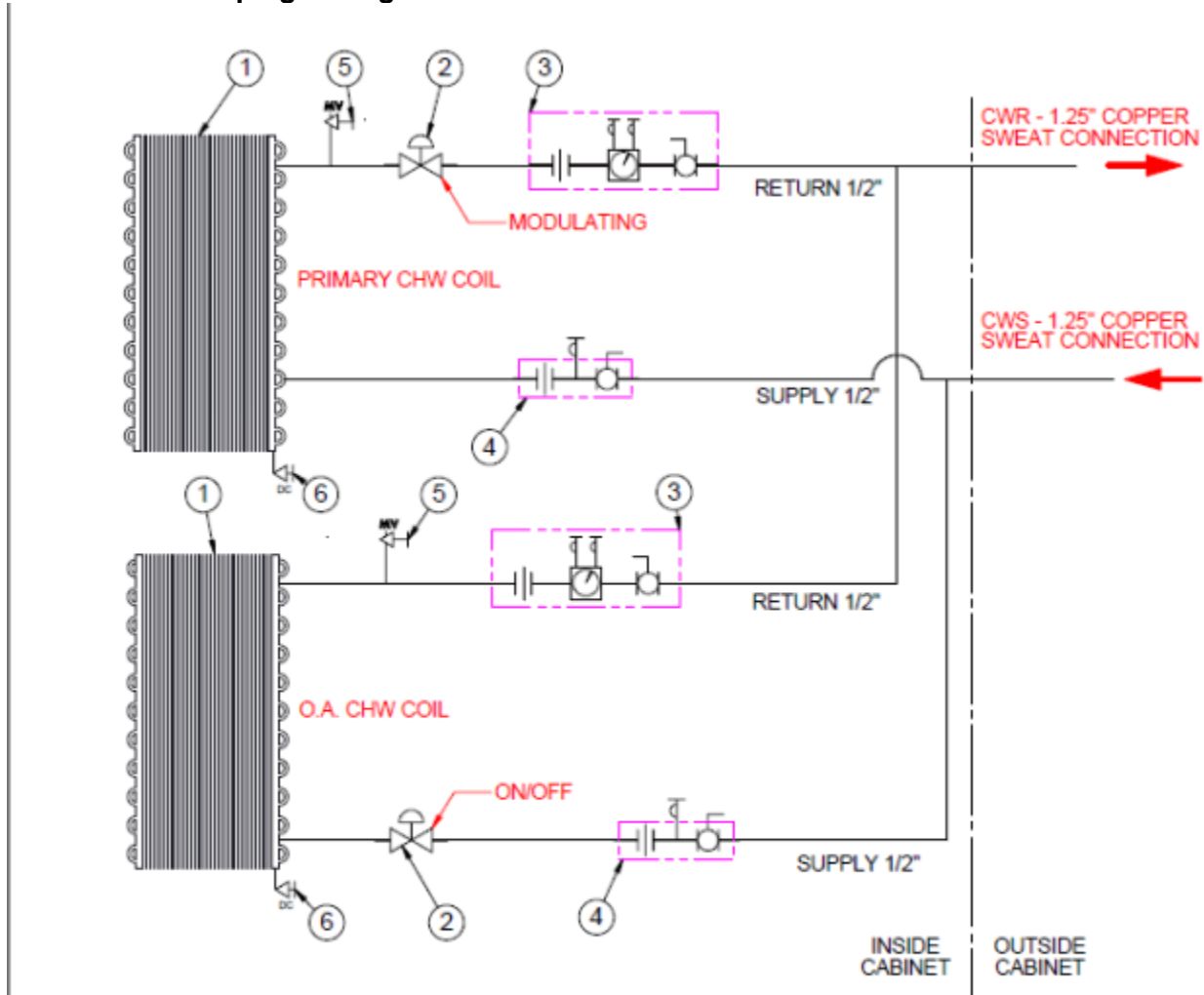

ITEM NO.	Note	QTY	Description
1		2	WATER COIL
2		2	2 WAY CONTROL VALVE
3		2	MANUAL BALANCING/BALL VALVE WITH MEMORY STOP, PT PORTS AND UNION
4		2	BALL VALVE WITH UNION & PT PORT
5		2	MANUAL AIR VENT
6		2	DRAIN COCK

Note: The component arrangement shown above may vary slightly from that in the unit supplied

Warning: City water is very corrosive to brass components. Provide water treatment as soon as the system is charged to avoid premature leaks and/ or failure of internal components.

DX Split System

The following is a typical split system refrigeration circuit.

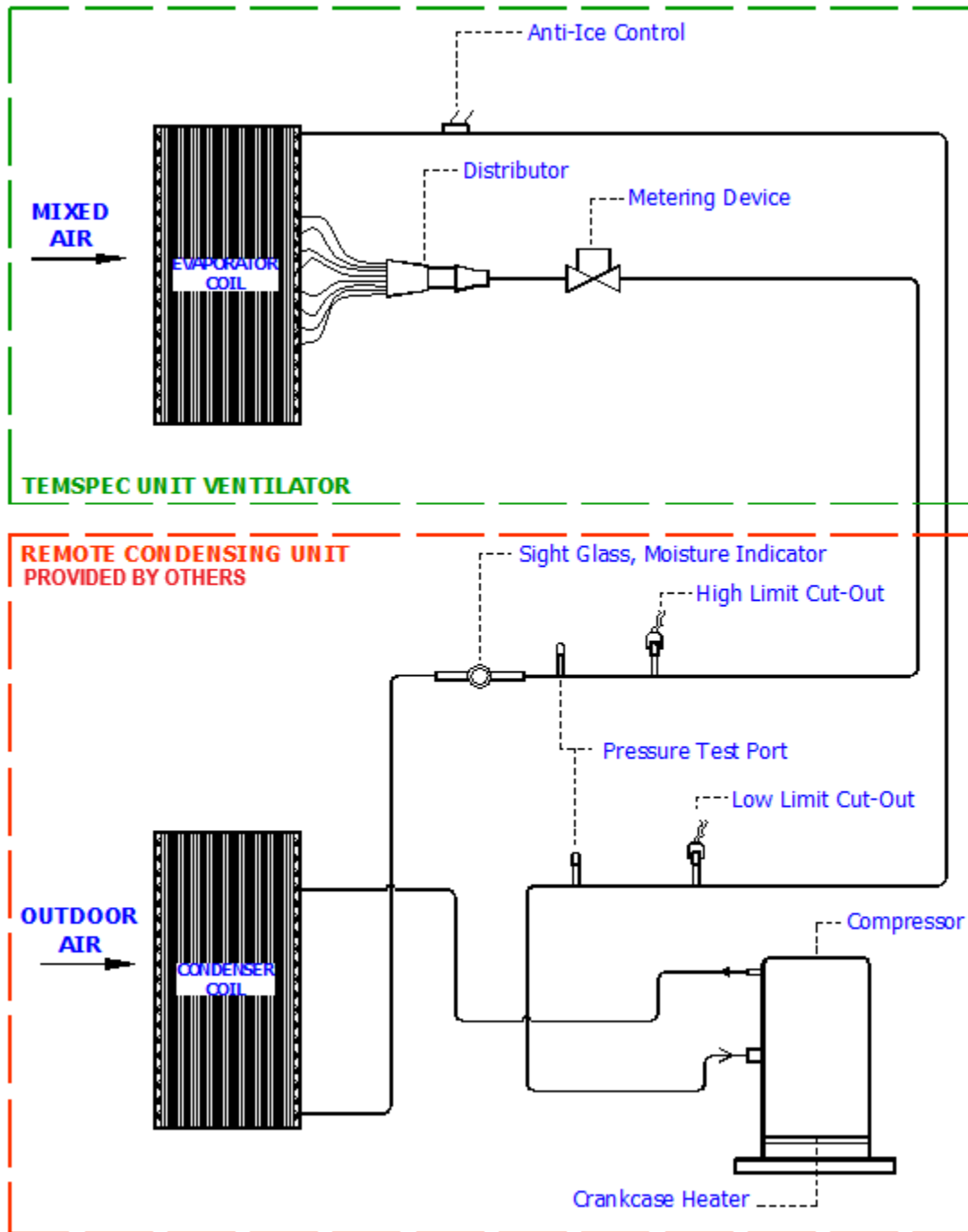

Note: The component arrangement shown above may vary slightly from that in the unit supplied

Steam Piping

Note: units with steam piping were previously certified to UL1995 4th ed. But will are not certified to UL 60335-2-40. They will be subject to a Special Inspection under code SPE-1000.

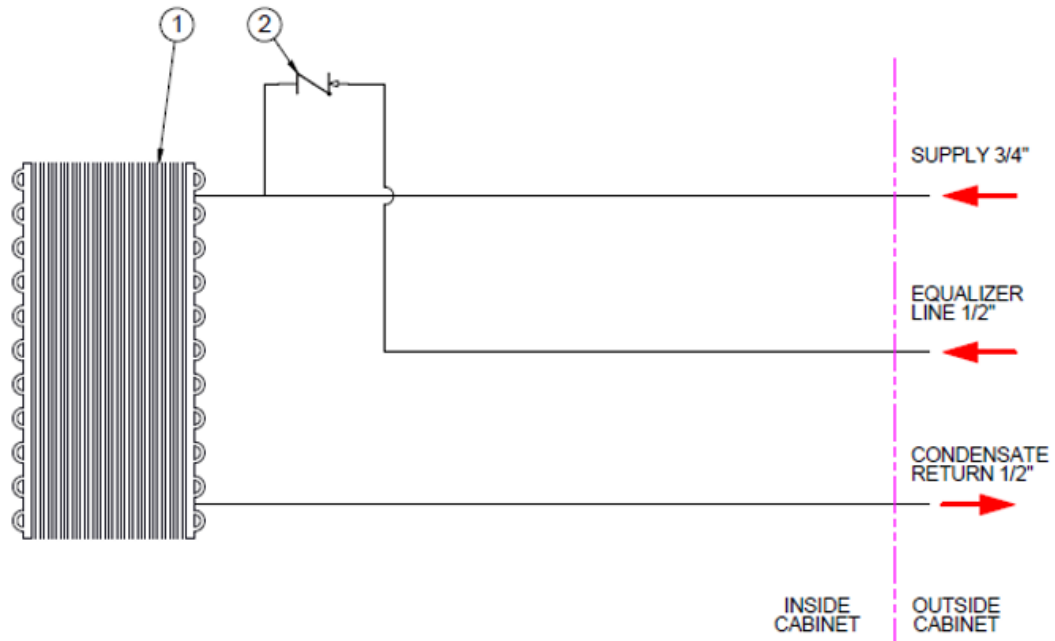

**MAX PRESSURE/TEMPERATURE
5 PSIG + 10° F SUPERHEAT**

NOTE: ALL ITEMS ARE SUPPLIED AND INSTALLED BY TEMSPEC.

ITEM NO.	Description	QTY	NOTE
1	COIL-STEAM	1	
2	CHECK VALVE	1	

Temspec steam units are designed to have a gravity fed condensate return. The Equalizer line is present to ensure there is not a vacuum formed in the system when the steam is not flowing. The line needs to be connected to a pipe that is at atmospheric pressure.

In a gravity return system the Condensate line is not pressurized and open to the atmospheric pressure, the Equalizer line can be connected to the condensate line after the external steam trap. If the Condensate line is pressurized, the Equalizer line should not be connected to the pressurized condensation return line.

Dampers

All dampers for outdoor air come standard with a spring return actuator. Internal dampers such as Face and Bypass dampers are non-spring return. If the unit has both an outdoor air damper and return air damper, they will be mechanically linked (excluding VER units which have an economizer damper and a return air damper). As the outdoor air dampers open, the return air dampers close. The damper actuator manufacturer can vary. Please refer to the wiring schematic for the damper actuator model type.

Powered Exhaust

Internal powered exhaust is an optional feature that is provided with our standard vertical series unit ventilators. This feature comes with a fan and damper module that is mounted into the return air section of the unit. Control should be set up by the temperature controls contractor to operate as an on/off device as the outdoor air damper opens and closes.

For the Energy Recovery units, the exhaust fan is a standard option. It is located in the middle of the unit near the Energy Recovery Wheel. The fan is standard two speed. Low speed during regular wheel operation and a high speed during economizer mode.

Filtration

Typically, 1" or 2" disposable filters are provided in the unit with an extra set shipped loose for when the unit is ready for start-up. Please refer to the Job Submittal for specific details on filter construction and thickness. Below are sizes and quantity per unit for the different model types.

Model Number	Filter location	Filter Size	Quantity per Unit
VUD, VDF, VUF, HCD 1200	Mixed Air (L-Type Damper)	12" x 20" nominal	2
	Mixed Air (Inline Damper)	20" x 20" nominal	1
VUD, HCD 1600	Mixed Air (L-Type Damper)	12" x 24" nominal	2
	Mixed Air (Inline Damper)	20" x 24" nominal	1
VUD 2000, VUF 1500	Mixed Air (Inline Damper)	16" x 21" nominal	2
VER 1800	Mixed Air	18" x 22" nominal	2
	Energy Recovery Module	12" x 20" nominal	2
VGB 1500, 1600	Return Air	12" x 24" nominal	2
	Outdoor Air	12" x 24" nominal	1

VER ERW Balancing Procedure

1. Prior to starting balancing, disconnect the power to the energy recovery wheel by disconnecting the wire harness plug that supplies power to the wheel.
2. If the unit has an Economizer damper, ensure the Economizer damper along with the economizer exhaust damper is in the closed position prior to commencing balancing.

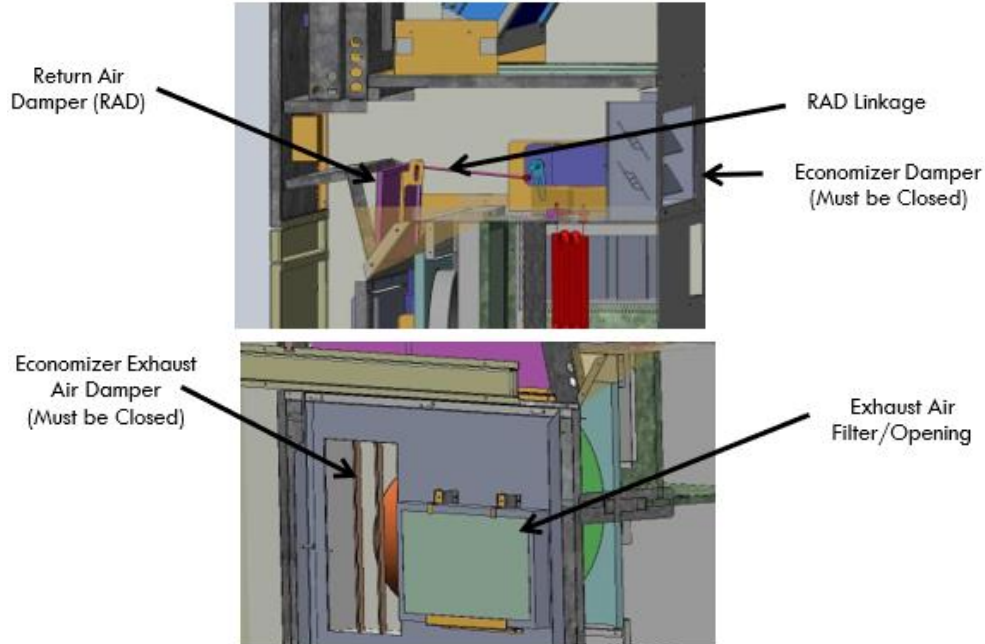

3. Ensure the unit is in "Occupied" mode. This will open the ERV Ventilation air and Exhaust air damper so that proper balancing can be completed.

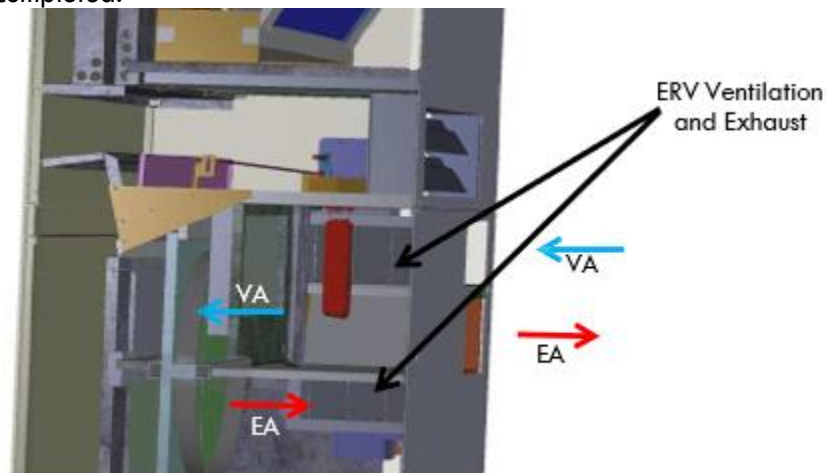

4. Balance the supply air to scheduled values via the supply air speed taps.
5. Balance the ventilation air and return air by using the temperature balancing method described below. Balance the fresh air on the Energy Recovery Wheel by using the return air damper. Adjust the RAD damper and linkage (figure 1) until the proper fresh air volume is achieved.
6. If additional restriction is required to achieve proper balancing, the Exhaust Air fan speed may be adjusted using the speed taps. Based on field conditions, the ERV exhaust air opening may require to be partially blocked off with sheet metal.

VGB Outdoor Air Balancing Procedure

Since the VGB units do not have mixed air dampers for adjusting the outdoor air, a few options are given to balance in the field.

Fan Speed Potentiometer

This dial allows adjust the outdoor air fan for quick smaller adjustments. The dial is located near the electrical box. The speed controller is labeled as SC in our electrical schematics.

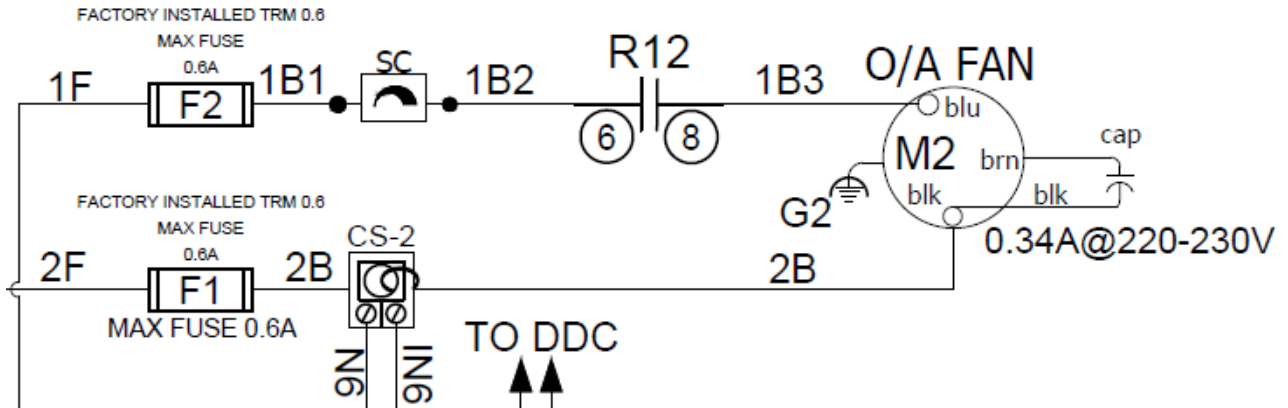

Outdoor Air Damper Stop

The VGB units have a physical stop on the outdoor air damper. This is preset by the factory based on test data but may need to be adjusted on site.

To adjust, get access by removing the OA Module Access panel. The stop can be adjusted by loosening the closest screw and rotating the stop. Rotating up allows more airflow, and down reduces the airflow.

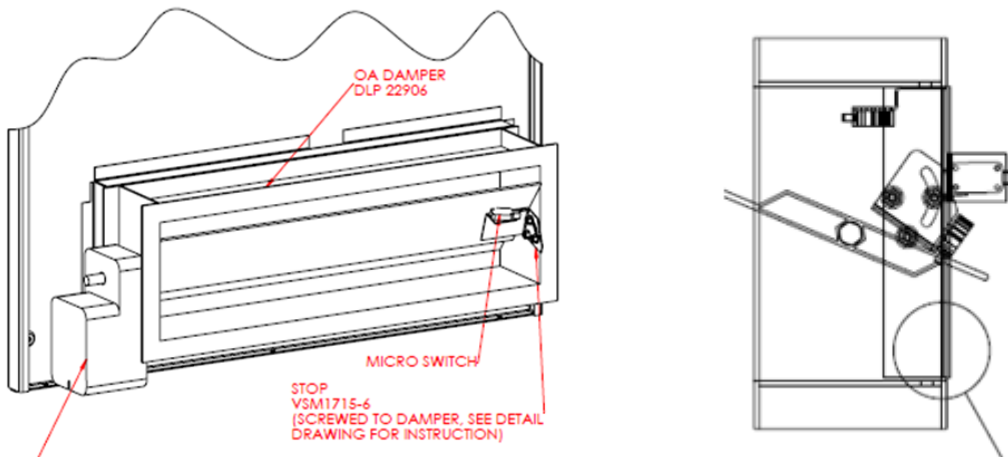

Return Air Block Off

This block off is only added on units where there is a higher ratio of outdoor air to return air and is located in the return air chamber after the grille.

This can be rotated to block off the return air to force more air to be drawn through the outdoor damper of the unit.

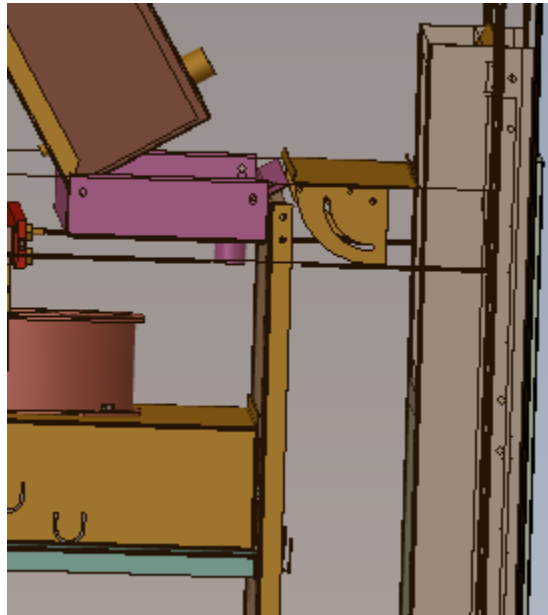



MAINTENANCE

Servicing the Unit

Access to the components is gained through front access panels. Typically, the panels are fastened by heavy duty Phillips head screws. If the units have hinged doors, loosen but do not remove the screws, and swing the door open. If the unit has removable panels, loosen but do not remove the screws, and carefully store the panel in a place where it will not get damaged. The horizontal style units utilize hinged access side panels with locking side supports to hold the panel open.

CAUTION: Disconnect power before servicing the unit.

The access panels have a door switch installed that will shut the supply air fan off once the panel is removed. This will only disconnect the power to the supply air fans. Be sure to disconnect ALL power by turning the remote disconnect switch to the off position.

Drain Pan Instruction

- Please check the drain pan for proper drainage as part of commissioning.
- Drain pan should be slopped towards the drain connection
- Check to make sure the drain pan overflow switch didn't come loose or shift during shipping as part of commissioning.
- The unit should be checked to ensure the drain pan is level, free of debris, and the drain line properly connected to the drain pan stub-out.

Maintenance Schedule

Frequency maintenance greatly depends on the surrounding conditions (inside and outside of the building). The following is a typical maintenance schedule for a classroom unit ventilator.

- Every **3 months** – Change filters
- Every **6 months** – Visually inspect the condition of the ERV desiccant wheel, clean if necessary
- Every **12 months** – Vacuum out drain pans
– Clean strainer in hydronic circuit (if applicable)
- Every **24 months** – Clean evaporator coil
– Vacuum any loose debris from interior of the unit
– Inspect dampers to ensure that there is a proper seal when closed

Changing the Filters

The outdoor and indoor conditions will determine the frequency of filter changes. Temspec recommends that the filters be changed every 3 months as a rule-of-thumb. Note that dirty filters will affect the overall performance of the unit.

To change the filters, open / remove the filter access panel, remove the filters, and replace with the new ones.

Cleaning the Coils

To clean the coil, purchase a suitable evaporator coil cleaning solution such as those offered by NUCALGON (www.nucalgon.com). Follow the manufacturer's instructions for use.

Note: Chlorine-based or anti-fungal “pucks” or “socks” are acceptable when placed in the drain pan. Be sure to vacuum the drain pan during the cleaning process.

If the filters are regularly changed, the heating coils do not require cleaning.

WARNING: Do NOT use chlorine-based cleaners or anti-fungal treatments on the aluminum fins of coil.

Motors

Tempspec provides motors that are permanently lubricated. No maintenance is required.

NOTE: Tempspec does not recommend the use of a Unit Ventilator during construction/drywall installation as a space heater or air conditioner. Motor exposure to drywall dust can reduce motor life and leads to premature failure

Cleaning the Energy Recovery Wheel

Tempspec recommends that the ERV desiccant wheel be cleaned with a vacuum periodically and that the use of a cleanser is only required when necessary. When cleaning the wheel with a vacuum take care not to damage the wheel's polymer material.

WARNING: Do NOT use ACID based solutions, AROMATIC solvents, STEAM OR WATER with temperatures GREATER than 170°F.

The clean desiccant coated polymer energy recovery wheel requires a non-acid based (evaporator) coil cleanser or alkaline detergent.

First you must gain access to the energy recovery wheel by removing the return air and ERV access panel by loosening the required fasteners. Once this is completed follow the recommended steps of the wheel manufacturer Airxchange listed below.

- Remove wheel from Unit Ventilator
- Remove the wheel from the cassette
- Remove loose accumulated dirt by brushing the wheel face
- Wash the wheel with a non-acid based (evaporator) coil cleanser or alkaline detergent solution. (The wheel manufacturer suggests cleaners such as KMP Acti-Klean in a 5% solution works well)
- If the wheel is extremely dirty it may be required to soak overnight to remove all contaminants.
- Once soaking is completed, rinse the solution from the wheel until the water comes clear.
- Allow excess water to drain and re-install cassette.

NOTE: There may be some staining to the desiccant, however this will not adversely affect the performance.

For more information, please see the ERV manufacturers' website:
<http://www.airxchange.com/resource-center-technical-notes.htm>

Removing the Energy Recovery Wheel

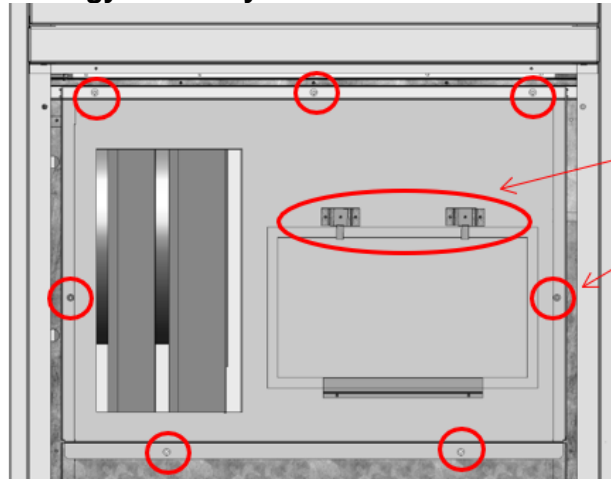

Remove filter - Open retaining clips and set filter aside.

Remove Energy Recovery Wheel access panel. Seven (7) x 1/4" nuts

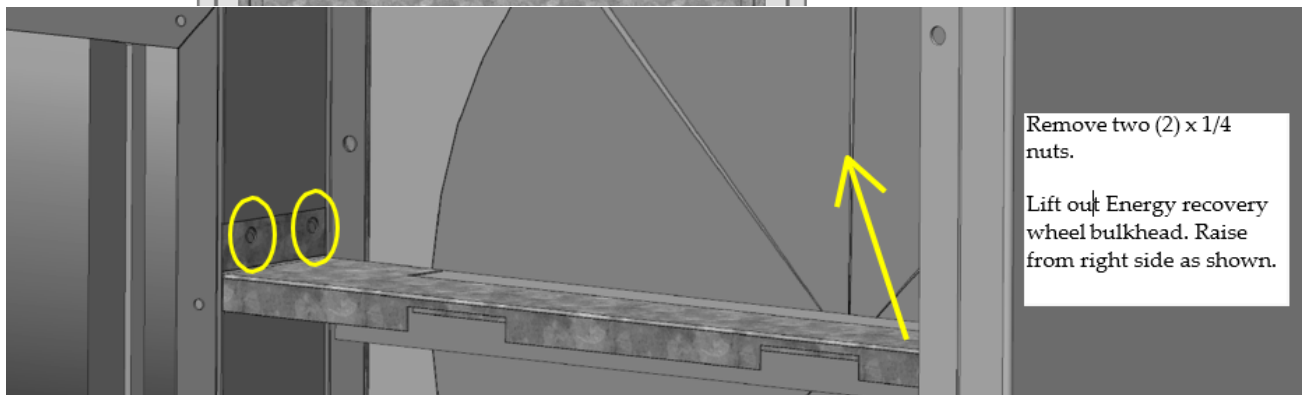

Remove two (2) x 1/4 nuts.

Lift out Energy recovery wheel bulkhead. Raise from right side as shown.

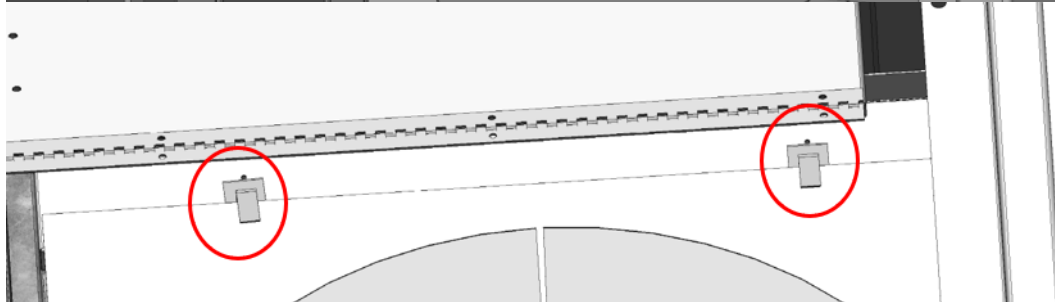

Open energy recovery wheel retaining clips. On top of wheel. (Somewhat hidden from sight.)

Disconnect energy recovery wheel power cable (Not shown).

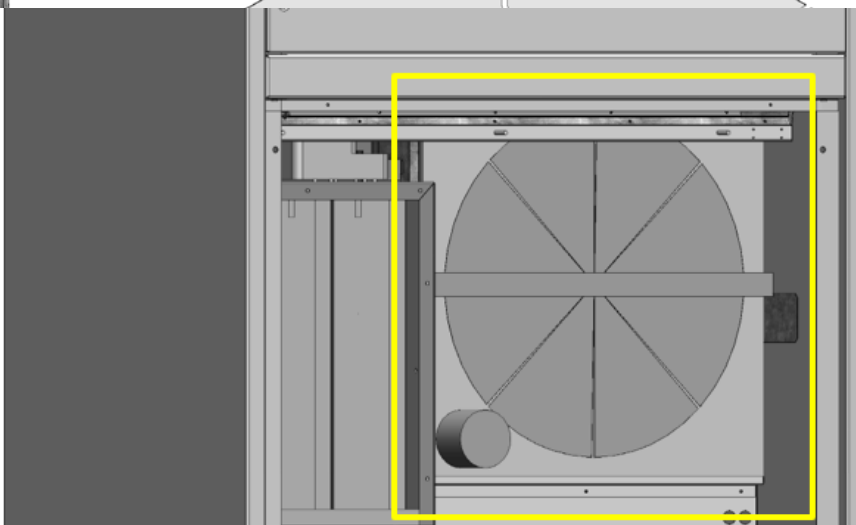

Remove energy recovery wheel by grasping the wheel assembly cross member. Lift up to clear bottom bracket. Rotate slightly and remove wheel.



Duct Attenuation

Attenuation of air noise from HVAC equipment in the classroom is critically important. The Temspec classroom fan coil units are constructed to minimize sound breakout from the cabinet by the use of heavy gauge steel and duct liner.

For units with a "Draw-Through" configuration (supply air fan at the top of the unit), air noise from the return air grille is negligible since the supply air blower is typically 7ft. distance from the return air opening. Supply air blower noise at the discharge must be adequately attenuated.

The following method is recommended for duct work associated with the classroom Unit Ventilators. Note: This recommendation only applies to the Draw-Though units that do not utilize Temspec's top acoustical plenum.

Fabricate the discharge elbow using heavy gauge steel, a minimum of 20ga. Line the elbow and first 8 ft. of duct with 1" duct liner. Line the remainder of the duct with a 1/2" duct liner. Pay particular attention to ensuring that there is no air leakage at the joint at the discharge from the unit. Do not use a flexible joint at the discharge as the blower and motor have vibration isolation mountings. Avoid locating supply air grilles / diffusers closer than 8ft. from the fan discharge.

Only one 90 degree elbow after the supply plenum in the first 5ft of ductwork.

Care should be taken for units with dual supply air blowers to ensure proper transitions to the ductwork to avoid excess air turbulence. The transition from the unit to the main duct must be symmetrical. Failure to follow these guidelines could cause fan turbulence that can generate noise.

External cladding of the elbow with a high density material will assist in reducing low frequency sound breakout.

Maximum Operating Conditions

Condition	Value
Max Water Temperature	200F
Min Water Temperature	40F
Max External Static Pressure Tested	0.5" W.C.
Max Operating Water Pressure	150PSI
Min Distance to Structure	0"
Refrigeration	R410A
Max Refrigeration Pressure	600PSI

TROUBLESHOOTING

Problem	Troubleshooting
Fan not running	Verify power to the motor
	Ensure all wiring connections are correct and secure
	Ensure the controller is sending the correct signal
	Check the fan relay is energizing properly
	Check the speed board is working (if applicable)
	Swap motor with a working unit to ensure motor is not failed
Damper not working	Ensure all wiring connections are correct and secure
	Ensure actuator is getting proper voltage
	Ensure controller is sending the proper control signal
Water valve not working	Ensure all wiring connections are correct and secure
	Ensure actuator is getting proper voltage
	Ensure controller is sending the proper control signal
	Check overflow switch is not tripped
Electric heat not working	Ensure all wiring connections are correct and secure
	Ensure heater relay is functioning and proper voltage is reaching the heater
	Ensure the controller is sending the correct signal
	Ensure the manual high temperature switch is not tripped
Outdoor Fan not supplying enough air	Adjust the speed control (VGB)
	Check the stopper bracket position on the the outdoor air damper, adjust if required (VGB Series)
	Balance fan
	Adjust speed taps (VER)
	Check the unit has a proper seal to the outside Louver
	Adjust the outdoor air damper minimum position

Accessories Instructions

For other accessories not listed, please contact Temspec.

Block-off Panel

NOTE: Please refer to the 'Unit Layout' and 'Application Layout' pages in these submittals for precise pipe & duct connection locations and additional accessories.

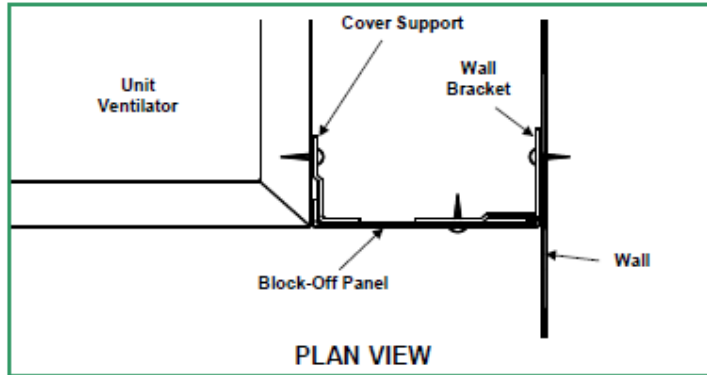
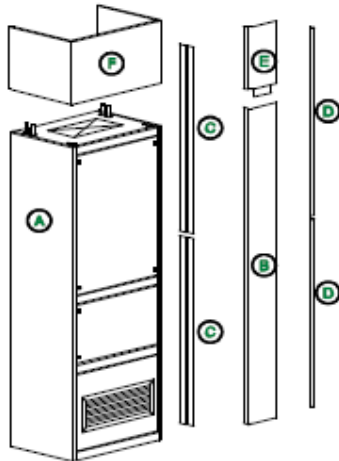

- A) Classroom Unit
- B) Block-Off Panel
- C) Cover Support
- D) Wall Bracket
- E) Block-Off Extension (if applicable)
- F) Top Extension or Plenum (if applicable).

NOTE: Installation screws NOT PROVIDED.

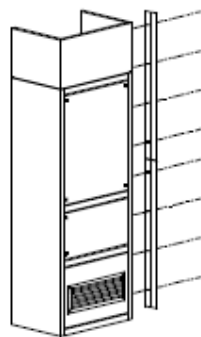

STEP 1:
Fasten COVER SUPPORT (C) to the side of the Classroom Unit, almost flush to the front edge. This bracket should be approximately 1" off of the finished floor level.

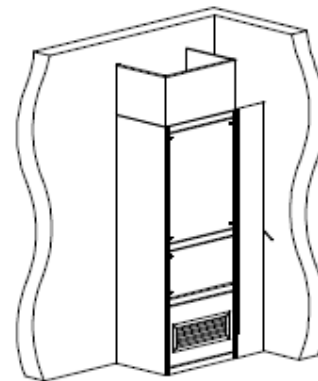

STEP 2:
Put the main BLOCK-OFF PANEL (B) into place and mark off where the edge of the panel meets the wall. Remove BLOCK-OFF PANEL.

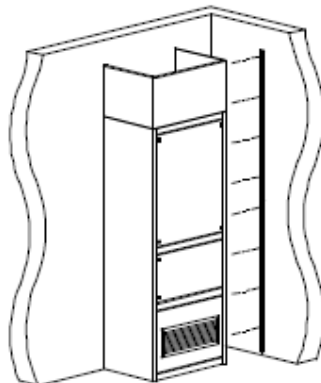

STEP 3:
Line up the edge of the WALL BRACKETS (D) to the mark from the previous step. Fasten brackets to the wall.

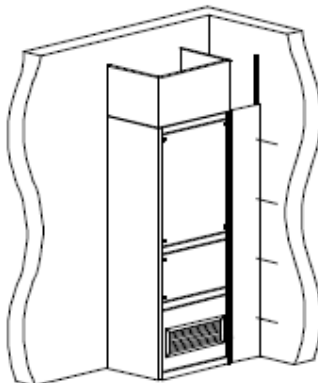

STEP 4:
Put the BLOCK-OFF PANEL (B) back into place. Fasten the BLOCK-OFF-PANEL to the WALL BRACKET (D) using flat head sheet metal screws (not provided).

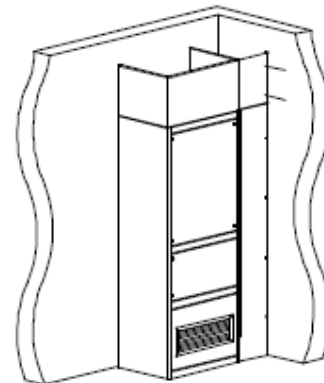

STEP 5:
If required, align the BLOCK-OFF EXTENSION (E) to the BLOCK-OFF PANEL (B) and fasten. Using the touch-up paint provided, paint screw heads to match the cover.

Side Pipe Cover

NOTE: Installation screws NOT PROVIDED.

NOTE: Please refer to the 'Unit Layout' and 'Application Layout' pages in these submittals for precise pipe & duct connection locations and additional accessories.

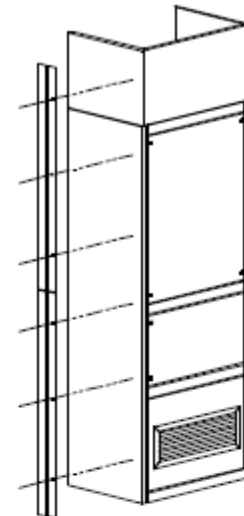
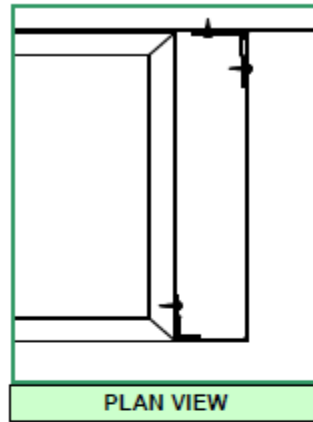
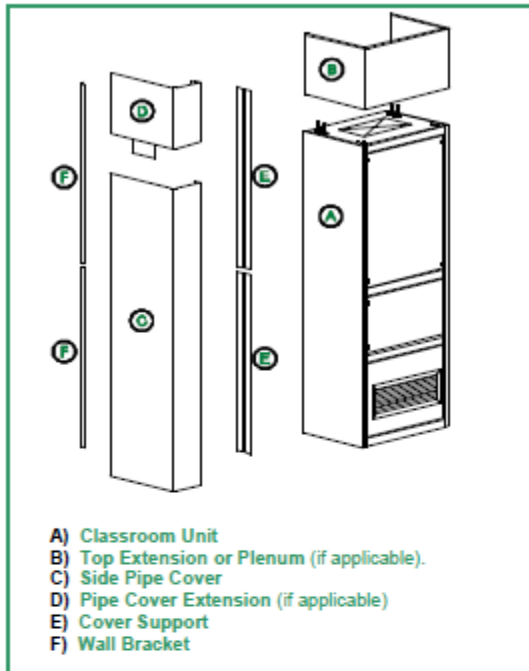

STEP 1:
 If applicable, install the top extension or plenum onto the CLASSROOM UNIT (A). Fasten the COVER SUPPORT (E) to the CLASSROOM UNIT. This bracket should be installed 1 inch off of the finished floor level.

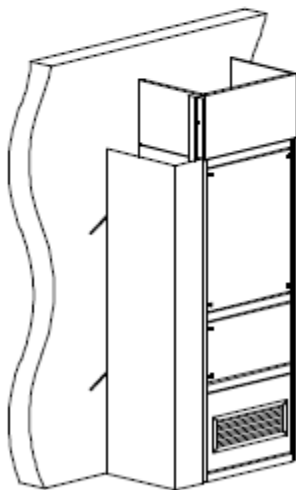

STEP 2:
 Put SIDE PIPE COVER (C) into place. Mark off where the edge of the SIDE PIPE COVER meets the wall.

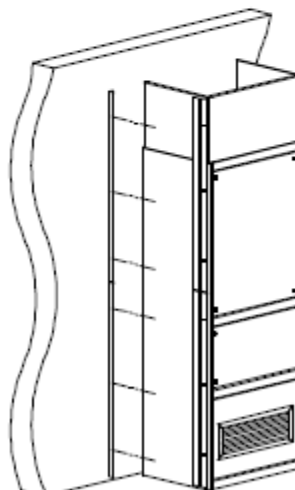

STEP 3:
 Remove the SIDE PIPE COVER (C). Install the WALL BRACKET (F) in relation to the 'Marks' on the wall (from previous step).

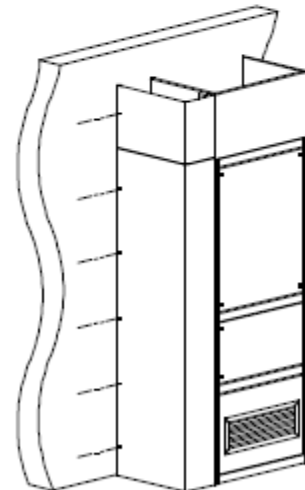

STEP 4:
 Put the SIDE PIPE COVER (C) back into place and fasten to the WALL BRACKETS (F) using flat head type screws. Install PIPE COVER EXTENSION (D) in the same fashion. Using the cabinet touch-up paint provided, touch up the screw heads to match the cabinet.

Top Extension

NOTE: Installation screws NOT PROVIDED.

NOTE:

Drawings are conceptual. Please refer to the 'Unit Layout' and 'Application Layout' pages in these submittals for precise pipe & duct connection locations and additional accessories.

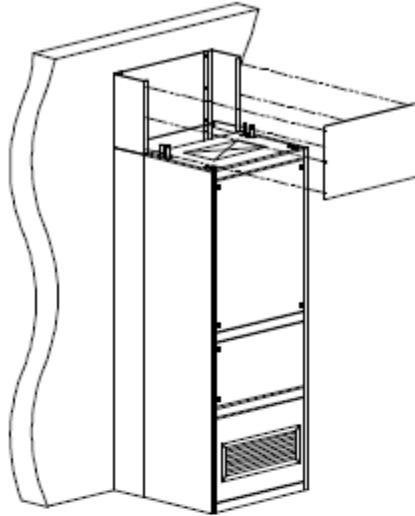
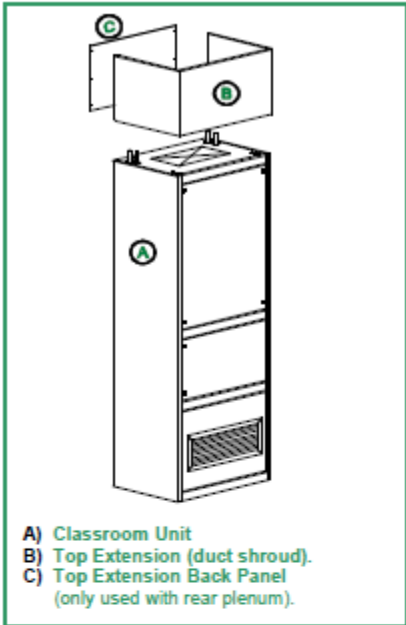

STEP 1:
 If a rear plenum is to be installed, proceed with **STEP 1**. Otherwise skip to **STEP 2**. Install rear plenum assembly as per the instructions provided. Attach the **TOP EXTENSION BACK PANEL (C)** to the front of the rear plenum extension assembly as shown.

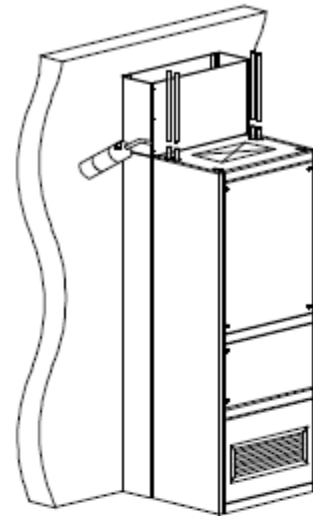

STEP 2:
 Make piping and electrical connections to the **CLASSROOM UNIT (A)** where required.

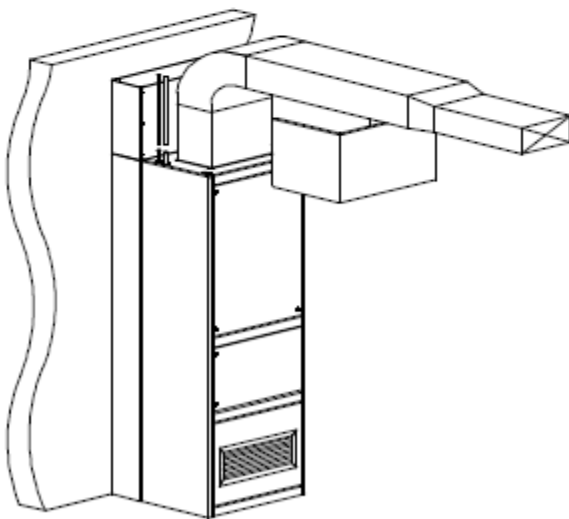

STEP 3:
 Install duct work (if applicable). Carefully slide **TOP EXTENSION (B)** on top of **CLASSROOM UNIT (A)** so that side edges are flush to the cabinet.

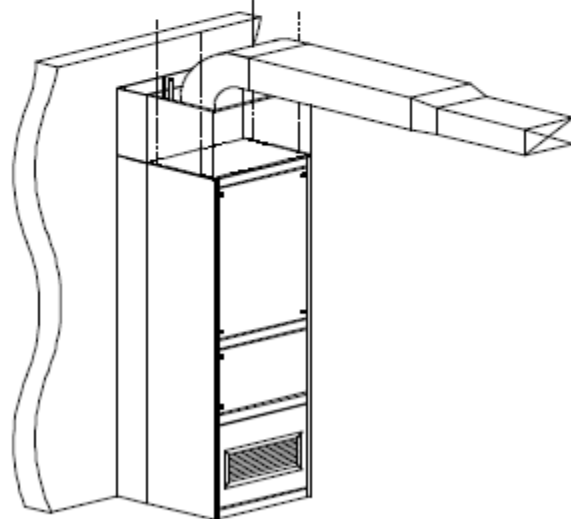

STEP 4:
 Fasten **TOP EXTENSION (B)** to the top of the **CLASSROOM UNIT (A)**.

Top Plenum – Direct Supply

NOTE: Installation screws NOT PROVIDED.

NOTE:

Drawings are conceptual. Please refer to the 'Unit Layout' and 'Application Layout' pages in these submittals for precise pipe & duct connection locations and additional accessories.

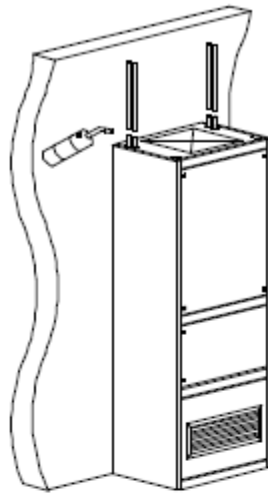
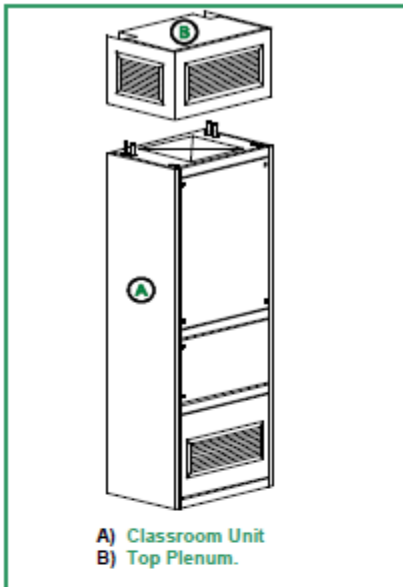

STEP 1:
Put the CLASSROOM UNIT (A) into place and make applicable piping connections.

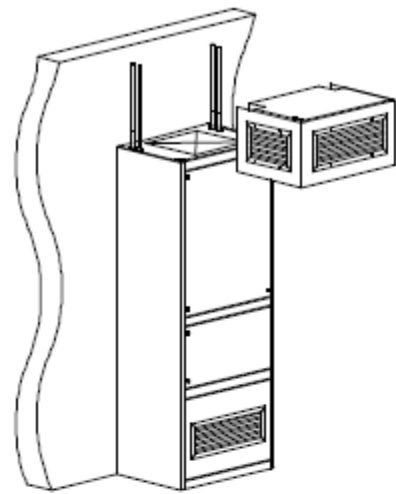

STEP 2:
Slide the TOP PLENUM (B) onto the CLASSROOM UNIT (A). Align the TOP PLENUM (B) to the CLASSROOM UNIT (A) so that the front, back and sides are flush.

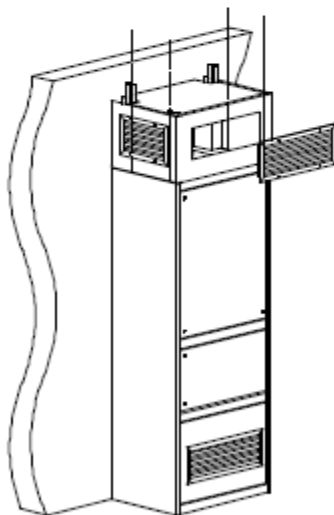

STEP 3:
Remove the supply air grille from the TOP PLENUM (B). Fasten the TOP PLENUM to the CLASSROOM UNIT (A) by securing the plenum flanges (located at the bottom of the plenum) to the top of the CLASSROOM UNIT with #8 self-drilling tapping sheet metal screws.

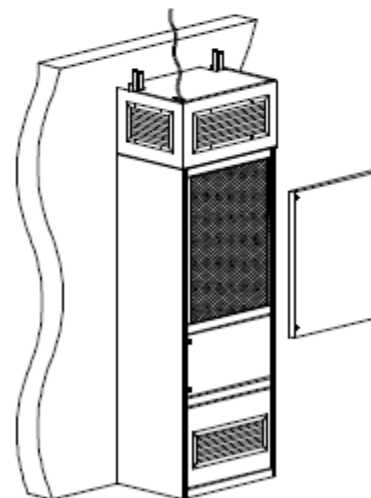

STEP 4:
Remove the top access panel of the CLASSROOM UNIT (C). Feed the electrical and control wiring through the TOP PLENUM (B) and through the top panel of the CLASSROOM UNIT. Make electrical connections inside of the electrical / control enclosure. Re-install the supply air grille.

Top Acoustical Plenum

NOTE: Installation screws, washers and sealing gasket NOT PROVIDED.

NOTE:

Drawings are conceptual. Please refer to the 'Unit Layout' and 'Application Layout' pages in these submittals for precise pipe & duct connection locations and additional accessories.

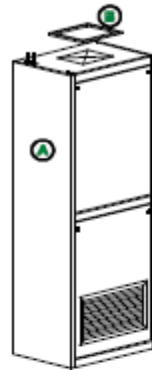
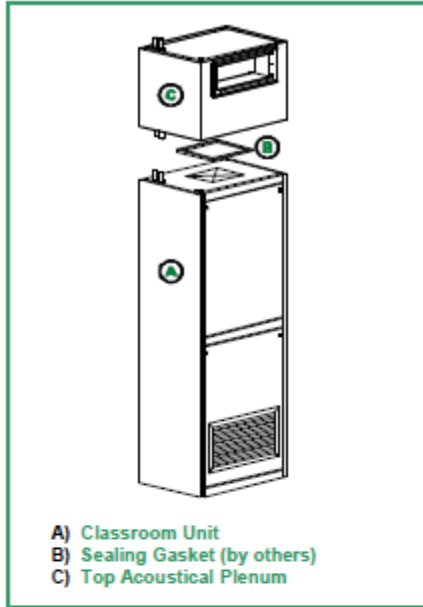

STEP 1:
Fit a suitable compressible **SEALING GASKET (B)** around the supply air fan discharge to prevent air leakage at the interface of the unit and the **TOP ACOUSTICAL PLENUM (C)**.

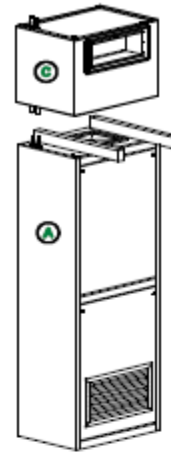

STEP 2:
Stand the **TOP ACOUSTICAL PLENUM (C)** onto two pieces of 2"x4" wood on top of the **CLASSROOM UNIT (A)**.

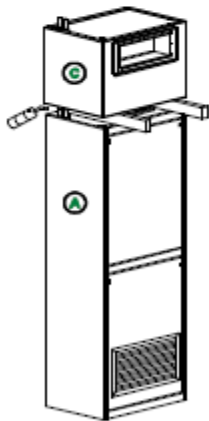

STEP 3:
Within the 4" gap, make soldered connections between the **CLASSROOM UNIT (A)** stub-outs and the bottom end of the pipe extensions in the **TOP ACOUSTICAL PLENUM (C)**. Remove the 2"x4" wood and allow the **TOP ACOUSTICAL PLENUM** to rest on the **CLASSROOM UNIT** squarely.



STEP 4:
Remove the top access panel of the **CLASSROOM UNIT (C)**. Locate the six 3/4" clearance holes in the top horizontal panel of the **CLASSROOM UNIT**. The holes are beneath the insulation. Using six 1/4" x 20 t.p.l. Screws and 1 1/4" O.D. flat washers under the screw heads, secure the top of the **CLASSROOM UNIT** to the **TOP ACOUSTICAL PLENUM (A)**. The **TOP ACOUSTICAL PLENUM** has weld nuts (flush mounted) on the bottom surface.

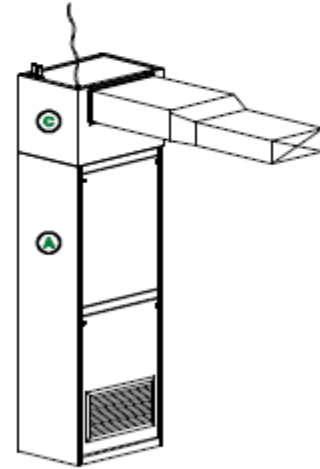
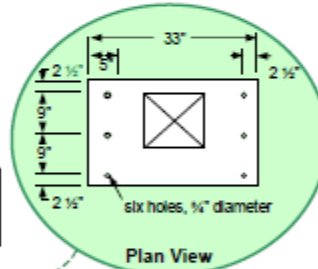

STEP 5:
Feed the power cable down through the 1" conduit, pre-installed within the **TOP ACOUSTICAL PLENUM (C)** and down into the **CLASSROOM UNIT (A)** to the terminal block within the electrical enclosure. Attach the duct to the pre-installed supply air collar on the **TOP ACOUSTICAL PLENUM (C)**.

Raised Base

NOTE: Installation screws, washers and sealing gasket NOT PROVIDED.

NOTE: Drawings are conceptual. Please refer to the 'Unit Layout' and 'Application Layout' pages in these submittals for precise pipe & duct connection locations and additional accessories.

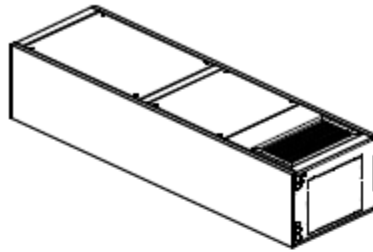
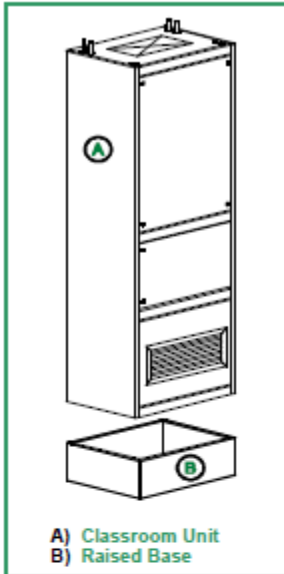

STEP 1: Lay down the CLASSROOM UNIT (A) carefully on the floor. **Note:** the CLASSROOM UNIT may slide during laying down operation. Special precautions should be taken by the installer to prevent damage or injury.

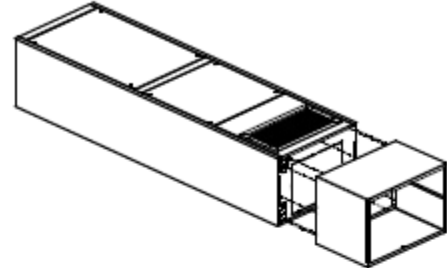

STEP 2: Align the RAISED BASE (B) to the bottom of the CLASSROOM UNIT (A) so that the front, back and sides are flush.

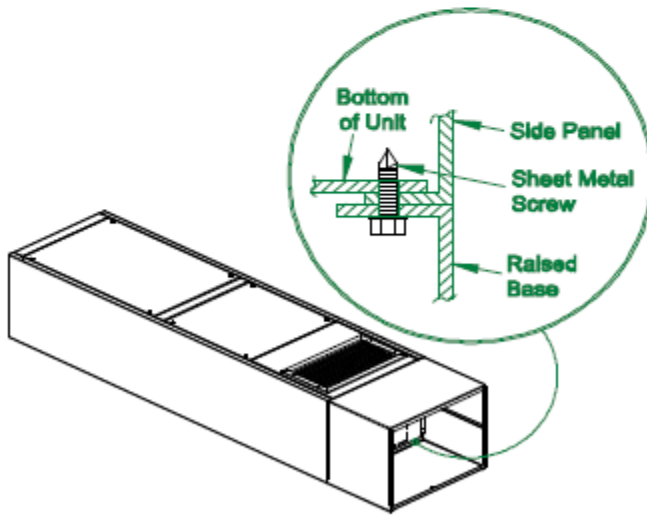

STEP 3: Using #8 self-drilling tapping sheet metal screws, fasten the RAISED BASE (B) to the CLASSROOM UNIT (A).

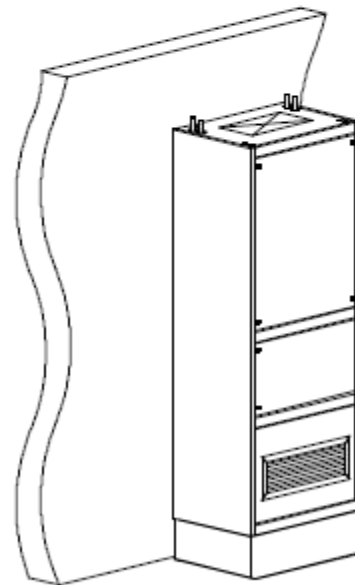

STEP 4: Carefully tilt the CLASSROOM UNIT (A) with the attached RAISED BASE (B) up to a vertical position. Continue with other installation steps.

Rear Plenum

NOTE: Installation screws NOT PROVIDED.

NOTE: Please refer to the 'Unit Layout' and 'Application Layout' pages in these submittals for precise pipe & duct connection locations and additional accessories.

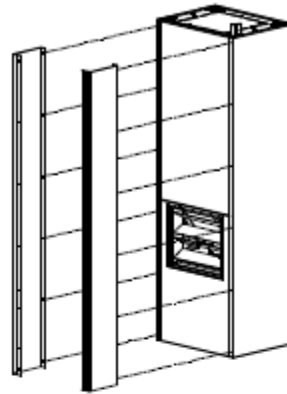
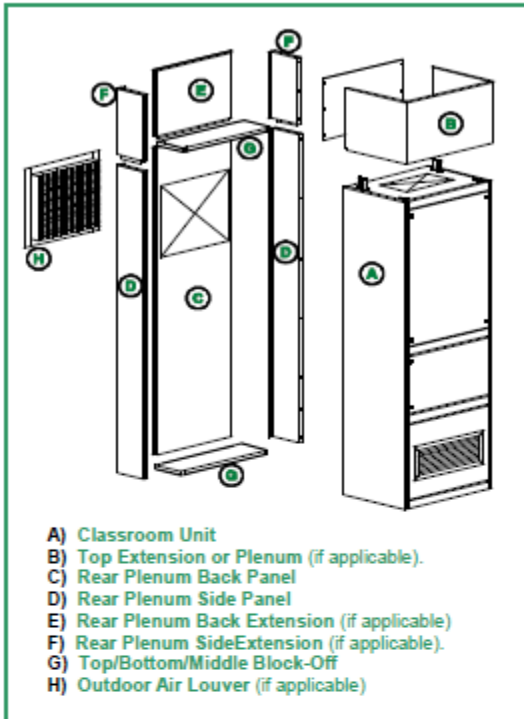

STEP 1:
 Using the pre-drilled holes on the REAR PLENUM SIDE PANELS (D), fasten the REAR PLENUM SIDE PANELS to the back of the CLASSROOM UNIT (A). Ensure that each REAR PLENUM SIDE PANEL is flush with the side of the CLASSROOM UNIT.

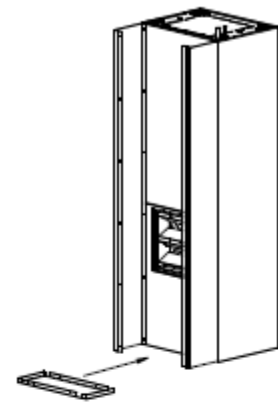

STEP 2:
 Insert the BOTTOM BLOCK-OFF (G) so that it is square to the CLASSROOM UNIT (A).

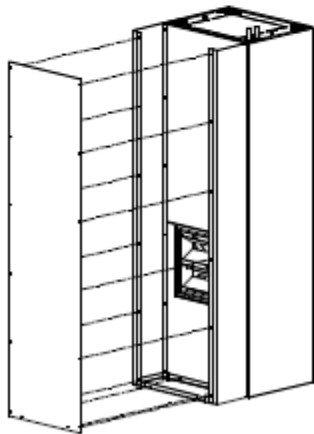

STEP 3:
 Fasten the BOTTOM BLOCK-OFF PANEL (G) to the back of the CLASSROOM UNIT (A). Using the pre-drilled holes, align and fasten the REAR PLENUM BACK PANEL (C) to the REAR PLENUM SIDE PANELS (D).

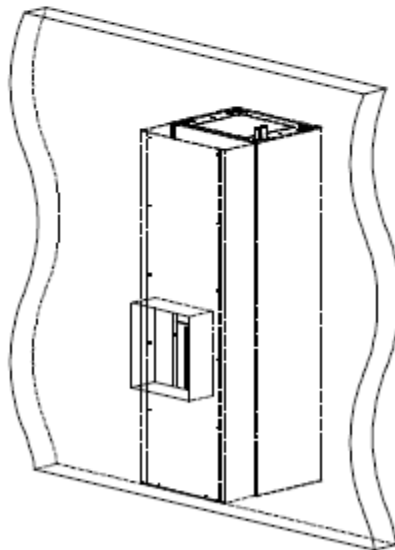

STEP 4:
 Center the CLASSROOM UNIT (A) to the wall opening. Cut the outdoor air intake opening in the REAR PLENUM BACK PANEL (C) to suit the wall opening.

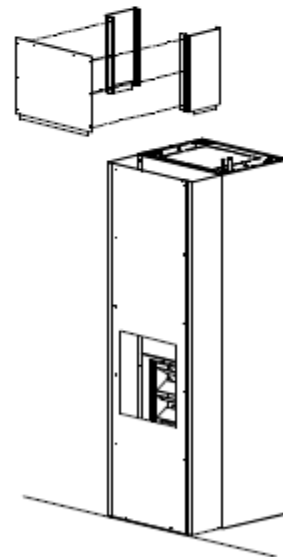

STEP 5:
 Using the pre-drilled holes, fasten the REAR PLENUM BACK EXTENSIONS (E) to the two REAR PLENUM SIDE EXTENSIONS (F). Insert the extension assembly into the top of the rear plenum.

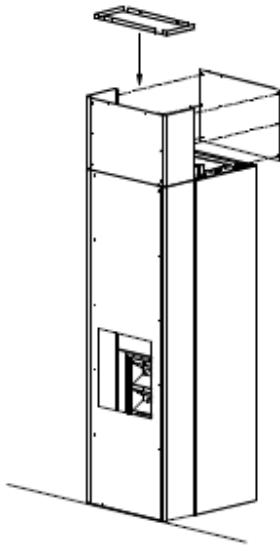

STEP 6:
Fasten the back piece of the TOP EXTENSION (B) to the REAR PLENUM SIDE EXTENSIONS (F). Insert the REAR PLENUM TOP BLOCK-OFF PANEL (G) into the top of the extension assembly.

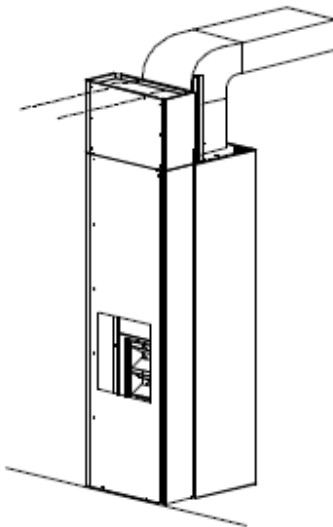

STEP 7:
Using the pre-drilled holes, fasten the REAR PLENUM TOP BLOCK-OFF PANEL (G) to the CLASSROOM UNIT (A) and to the REAR PLENUM BACK EXTENSION (E). Where required, make duct and pipe connections to the CLASSROOM UNIT (A).

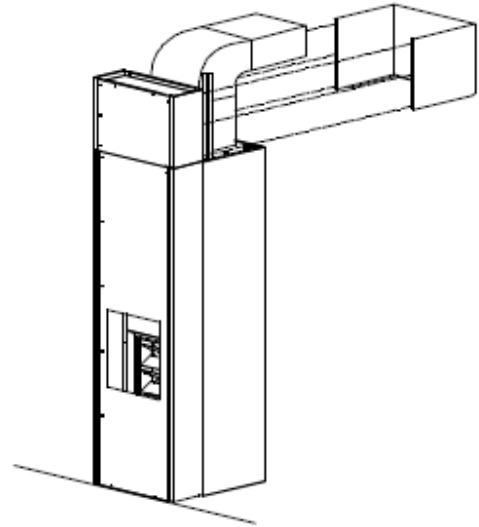

STEP 8:
If applicable, slide the TOP EXTENSION (B) into place and fasten to the top extension back panel.

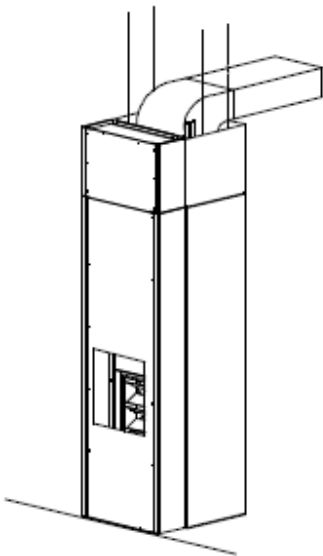

STEP 9:
Secure the TOP EXTENSION (B) to the top of the CLASSROOM UNIT (A) (if applicable).

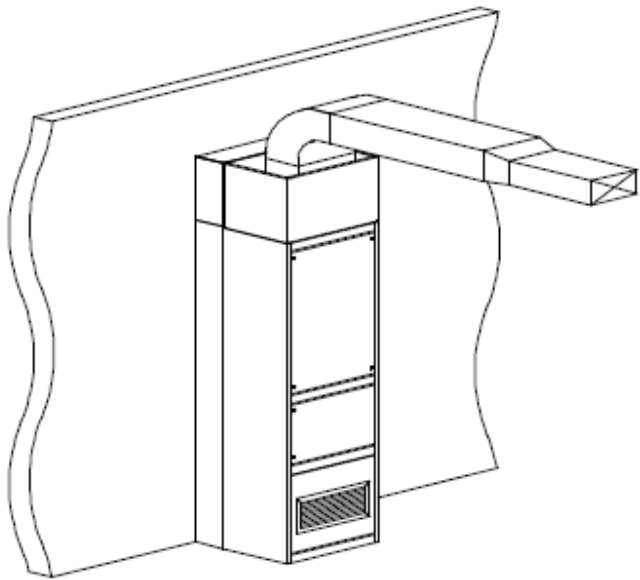

Wall Assembly

NOTE:

Installation screws and caulking NOT PROVIDED.

If a REAR PLENUM is installed, the rear collar and weather strip will not be provided.

NOTE:

Drawings are conceptual. Please refer to the 'Unit Layout' and 'Application Layout' pages in these submittals for precise pipe & duct connection locations and additional accessories.

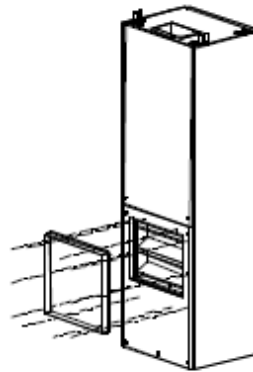
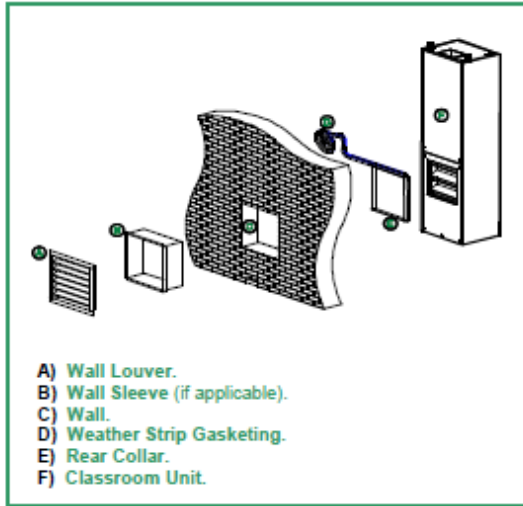

STEP 1:
Attach the 2" deep REAR COLLAR (E) to the back of the CLASSROOM UNIT (F) using the pre-drilled holes.

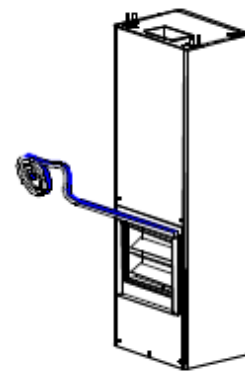

STEP 2:
Apply the self-adhesive 1" square foam WEATHER STRIP (D) around the outside of the REAR COLLAR (E). This is to prevent outdoor air leakage into the room from around the perimeter of the wall opening.

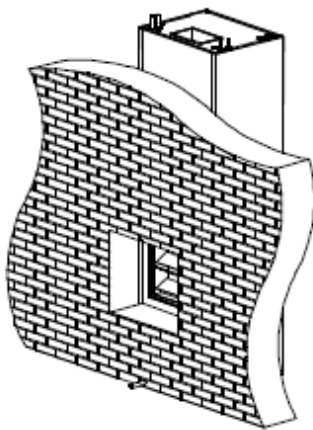

STEP 3:
For units with a cooling coil, a 5/8" vinyl condensate tubing is coiled up in the return section for field use. Before proceeding to Step 4, determine where the condensate line will drain out. If the condensate line is to exit through the wall, then refer to the submittals for condensate opening locations on the CLASSROOM UNIT (F).

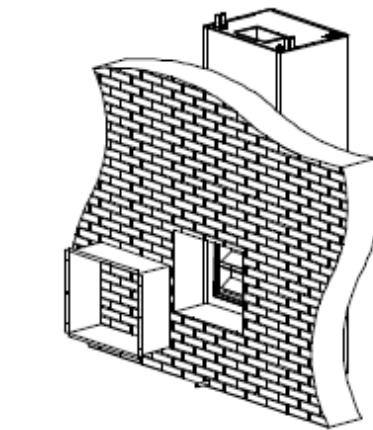

STEP 4:
Push the CLASSROOM UNIT (F) into position with the REAR COLLAR (E) penetrating the wall opening, compressing the foam WEATHER STRIP (D). Plumb the CLASSROOM UNIT using shims if necessary. Insert the WALL SLEEVE (B) into the wall opening from outside the building. The WALL SLEEVE is an inside fit into the REAR COLLAR (E). Secure the sleeve to the side flange (NOT BOTTOM) of the REAR COLLAR. Caulk all joints.

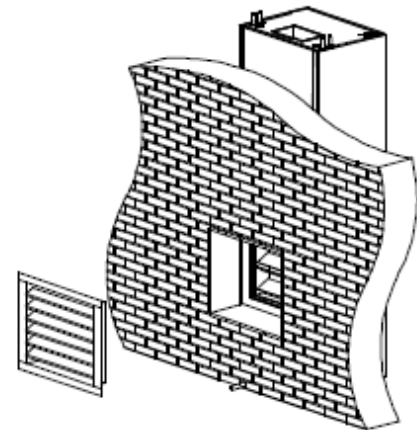

STEP 5:
Insert the LOUVER (A) into the WALL SLEEVE (B) and secure to the WALL (C). Caulk the top horizontal edge and two side vertical edges of the WALL LOUVER (A). DO NOT CAULK THE BOTTOM HORIZONTAL EDGE.

UVC Light

UVC lights are installed in the blower housing and only available in Draw Through unit layouts with ducting.

To avoid UVC exposure, there **MUST** be at least 8ft of internally insulated ductwork between the first supply air grille/ diffuser and the fan discharge. The insulation must UVC rated and non reflective (i.e., not aluminum foil insulation).

The UVC light has a built-in airflow sensor, so the light will turn on and off to match the blower, extending the life of the bulb. The bulb is rated for 50,000 hours of operation. Cleaning of the UVC bulb is not required.

The UVC light is UL2998 rated and will not produce ozone.

Do not operate the UVC light if obviously damaged. Unintended use of the unit, or damage to housing may result in the escape of dangerous UVC radiation. UVC radiation may, even in small doses cause harm to the eyes and skin.

Access panels bearing the ultraviolet radiation hazard symbol which may have UV-C SPECTRAL IRRADIANCE greater than 1,7 $\mu\text{W}/\text{cm}^2$ are provided with an interlock switch to interrupt the power to the UV-C LAMPS for your safety. Do not override.

Before opening doors and access panels bearing the ULTRAVIOLET RADIATION hazard symbol for the conducting USER MAINTENANCE, it is recommended to disconnect the power.

UV-C BARRIERS bearing the ULTRAVIOLET RADIATION hazard symbol should not be removed.

Do not operate UV-C LAMPS outside of the appliance.

Replacing the UVC Bulb

Ensure power is disconnected from the UVC light and the bulb has cooled after operation.

Remove the cover and disconnect the wiring from the LED module. Remove the bulb from the blower and dispose of the bulb appropriately.

When installing the new bulb (Temspec Part# EUV 30843), be sure to not touch the bulb with bare hands as oil from hands may damage the bulb.

For more information, please contact the factory.

REPLACEMENT PARTS

Limited Warranty

TEMSPEC INCORPORATED warrants the equipment from factory defects in material or workmanship for a period of one year from installation or 18 months from the date of shipment, whichever occurs first.

For this warranty to be valid, the unit(s) must be installed and maintained in accordance with the manufacturer's printed instructions. It does not cover parts damaged by vandalism, improper installation, maintenance, or abuse.

Should any replacement parts be required within the warranty period, they will be supplied at no charge, freight prepaid to the jobsite. The cost of labor or incidental expenses incurred in the repair or replacement of parts does not form part of this warranty.

The warranty period commences from the date of shipment, except when otherwise agreed at the point of sale (see specific warranty terms and conditions for details).



Part Sales

Contact the factory at: 1-888-TEMSPEC or (905) 670-3595

sales@temspec.com

Ask for 'parts sales'

Be sure to provide the unit serial number, which is located on the ETL label, on the electrical box

 <p>2360 MILLRACE COURT MISSISSAUGA, ONTARIO CANADA L5N 1W2</p>	<p>MIN. INSTALLATION CLEARANCE TO COMBUSTIBLE SURFACE IS 0" LE DEGAGEMENT MINIMUM D'UNE SURFACE COMBUSTIBLE EST DE 0 POUCHES</p> <p>USE COPPER SUPPLY WIRES UTILISER DES FILS D'ALIMENTATION EN CUIVRE</p>	<p>Floor: _____ Riser: _____ Room: _____</p>	 <p>Intertek 4008161</p>
	<p>CONFORMS TO UL STD. 1995 & CERTIFIED TO CSA STD. C22.2 NO. 236</p> <p>SERIAL No. JJJJJYYMM ###</p>		
<p>MODEL No. <input type="text"/></p> <p>No. DE MODELE <input type="text"/></p> <p>MIN. CIRCUIT AMPACITY <input type="text"/> A AMPACITE DE CIRCUIT MINIMUM</p> <p>ELEC. RATING <input type="text"/> V/PH/Hz CAPACITE ELECTRIQUE</p> <p>COMPRESSOR <input type="text"/> RLA <input type="text"/> LRA COMPRESSEUR</p> <p>COND./EXHAUST FAN <input type="checkbox"/> X <input type="text"/> HP <input type="text"/> FLA VENTILATEUR A CONDENSATION/ÉCHAPPEMENT</p> <p>SUPPLY FAN <input type="checkbox"/> X <input type="text"/> HP <input type="text"/> FLA VENTILATEUR DE SOUFFLAGE</p> <p>O/A INTAKE FAN <input type="checkbox"/> X <input type="text"/> HP <input type="text"/> FLA VENTILATEUR D'ADMISSION DE L'AIR EXTÉRIEUR</p> <p>ELECTRIC HEATER <input type="text"/> V/PH/Hz <input type="text"/> kW RADIATEUR ÉLECTRIQUE</p> <p>REFRIGERANT TYPE <input type="text"/> LBS TYPE DE RÉFRIGÉRANT</p> <p>PRESSURE HIGH SIDE <input type="text"/> PSIG LOW SIDE <input type="text"/> PSIG PRESSION CÔTÉ HAUT CÔTÉ BAS</p> <p>REMOTE CONDENSER TYPE <input type="text"/> GENRE DE CONDENSATEUR À DISTANCE</p> <p>REFERENCE CODE <input type="text"/> CODE DE RÉFÉRENCE</p>	<p>MAXIMUM OVERCURRENT PROTECTIVE DEVICE <input type="text"/> A MAXIMAL DU DISPOSITIF DE PROTECTION CONTRE LES SURINTENSITÉS</p> <p>SHORT CIRCUIT CURRENT RATING <input type="text"/> kA COURANT DE COURT-CIRCUIT NOMINAL</p> <p>MAX. EXT. S.P. <input type="text"/> IN. H₂O PRESSION STATIQUE EXTÉRIEURE MAXIMUM po H₂O</p> <p>MAX. INLET WATER TEMP. <input type="text"/> °F TEMPÉRATURE MAXIMALE DE L'EAU D'ENTRÉE</p> <p>MAX. STEAM PRES. <input type="text"/> PSIG PRESSION MAXIMUM DE VAPEUR</p> <p>MAX. OUTLET AIR TEMP. (ELEC. HEAT ONLY) <input type="text"/> °F TEMP. DE SORTIE MAX. DE L'AIR (CHAUFF. ÉLEC. SEULEMENT)</p> <p>CONDENSATE PUMP <input type="text"/> A POMPE À CONDENSAT</p> <p>ENERGY RECOVERY WHEEL <input type="text"/> A ROUE À RÉCUPÉRATION D'ÉNERGIE</p> <p>UV LIGHT <input type="text"/> A LUMIÈRE ULTRA-VIOLETTE</p>		
	<p>OA ELECTRIC HEATER <input type="text"/> V/PH/Hz <input type="text"/> kW RADIATEUR ÉLECTRIQUE DE L'AIR EXTÉRIEUR</p>		