

The background features a detailed technical drawing of a vertical stack fan coil unit, rendered in white lines against a teal-to-green gradient. The drawing shows the unit's internal components, including a fan, coils, and ductwork, with various parts labeled with alphanumeric codes. The unit is shown in a perspective view, appearing to sit on a grid of hexagonal cells that recedes into the distance.

VERTICAL STACK FAN COIL UNITS

TECHNICAL CATALOG

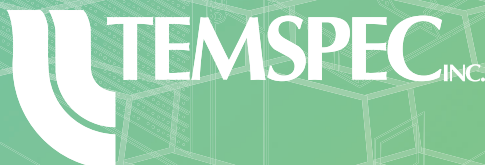

Technical Data

- 4** Cooling Capacities
- 4** Electric Heat
- 5** Heating Capacities
- 6** Backward Inclined Impeller Fan Performance
- 6** Backward Inclined Impeller Fan Motor
- 7** Sound Power Data

Products

- 8** TL Series Description
- 9** TL Series - 2 Pipe - Unit Layout
- 10** TL Series - 4 Pipe - Unit Layout

- 11** TM Series Description
- 12** TM Series - 2 Pipe - Unit Layout
- 13** TM Series - 4 Pipe - Unit Layout

- 14** TF Series Description
- 15** TF Series - 2 Pipe - Unit Layout
- 16** TF Series - 4 Pipe - Unit Layout

- 17** TR Series Description
- 18** TR Series - 2 Pipe - Unit Layout
- 19** TR Series - 4 Pipe - Unit Layout

Features and Details

- 20** Return Air Access Panels
- 21** Supply Air Configurations
- 22** Supply Air Openings
- 23** Risers
- 24** Riser Pipe/Coil Connections
- 25** Riser Installation
- 26** Filters & Unit Weights
- 27–29** Mechanical Specifications

Tempspec has been manufacturing vertical stack fan coil units since 1971. With over 50 years of experience, we build great relationships manufacturing customized, reliable, efficient HVAC solutions. Located in Mississauga, Ontario, Canada, we provide vertical stack fan coil units for our vast rep network across North America.

Tempspec vertical stack fan coil units are truly unique in the market. Whether you're designing a condo, hotel, dorm, barracks, or assisted living facility, we can find the right solution to meet your needs.

Tempspec redesigned our fan coil units to utilize backward inclined (BI) impeller fans, instead of forward curved blowers with direct drive motors. These BI fans allow us to operate our units like a VAV. The BI fans are 0-10 VDC ECM out of the box, and by using this strategy, we get unparalleled energy efficiency, reduced noise, and better dehumidification.

The fan will start at a minimum cfm, and attempt to maintain set point at that ultra low cfm for up to 66% of operation, ramping up to a maximum cfm less than 10% of the time. Traditional three speed control will start at high and ramp down as set point is reached, consuming more energy, and making more noise. The annualized average watts consumed by our fans are half those of a traditional three speed ECM in a forward curved blower.

Dehumidification is achieved when running at minimum cfm, with the CW valve full open. The low air volume across the coil, with full flow through the coil will wring the moisture out of the air and will condense on the coil. A much simpler, less expensive, and more energy efficient strategy than reheat. The air velocity at the minimum cfm is also less than 50 fpm, so no drafts or occupant discomfort will be felt.

When we introduced the BI fan, we also implemented a few other changes:

- 1" glass fiber insulation using a duct liner that is rated for 6,000 fpm, 4x the air velocity in a fan coil unit. This is the best option for cost, thermal and acoustical needs.
- Polymer drain pans for our TL and TM series of units (300 thru 800 cfm unit sizes). Unlike galvanized or stainless steel options, does not sweat, and will not corrode, and again is the best cost option.
- RA panel options (Hinged/Louvered or Perimeter type) have no visible fasteners for a clean installation, and make filter changing easy, without the use of tools. Regular changing of the filter is the most important part of fan coil maintenance. Making this easy to achieve, with minimal mess, and occupant disruption is a significant upgrade from traditional camlock style panels.
- Small footprints for our units take up less sqft of the space. 15 3/4" x 15 3/4" for our TL/TM series 0300/0400 is the smallest footprint for a "1 ton" fan coil unit. The 18" depth of our larger units, is 2-4" less than those of others. These small footprints provide for the space to re-route piping and electrical connections when replacing existing units.



Cooling Capacities

AHRI Certified Ratings

All models tested at 0.0" W.C. external static pressure

Motor type is ECM, voltage 115V/1/60. Airflow under dry coil conditions

Model	Coil Rows	Fins per Inch (fpi)	Air Flow (cfm)	EAT db (F)	EAT wb (F)	EWT (F)	LWT (F)	Flow Rate (gpm)	Total Capacity (MBH)	Sensible Capacity (MBH)	WPD (ft H2O)	Power Input (Watts)
0300	3	12	300	80.0	67.0	45.0	55.0	1.95	8.3	6.0	3.7	40
0300	4	12	300	80.0	67.0	45.0	55.0	2.14	9.1	6.5	3.4	40
0400	3	12	400	80.0	67.0	45.0	55.0	2.40	10.2	7.6	5.1	79
0400	4	12	400	80.0	67.0	45.0	55.0	2.63	11.2	8.2	4.9	79
0600	3	12	600	80.0	67.0	45.0	55.0	4.20	17.9	12.5	11.7	79
0600	4	12	600	80.0	67.0	45.0	55.0	4.80	20.4	13.7	19.1	79
0800	3	12	800	80.0	67.0	45.0	55.0	5.10	21.7	16.3	16.4	171
0800	4	12	800	80.0	67.0	45.0	55.0	5.90	25.2	18.1	17.9	171
1000	3	12	1000	80.0	67.0	45.0	55.0	6.80	29.0	21.1	15.2	213
1000	4	12	1000	80.0	67.0	45.0	55.0	7.90	33.7	23.5	16.5	213
1200	3	12	1200	80.0	67.0	45.0	55.0	7.60	32.4	24.2	18.8	348
1200	4	12	1200	80.0	67.0	45.0	55.0	9.00	38.2	27.2	19.9	348
0300	3	14	300	80.0	67.0	45.0	55.0	2.10	9.0	6.3	4.5	40
0300	4	14	300	80.0	67.0	45.0	55.0	2.30	9.8	6.7	3.7	40
0400	3	14	400	80.0	67.0	45.0	55.0	2.60	11.0	8.0	6.6	79
0400	4	14	400	80.0	67.0	45.0	55.0	2.80	12.0	8.6	5.6	79
0600	3	14	600	80.0	67.0	45.0	55.0	4.50	19.2	13.2	12.9	79
0600	4	14	600	80.0	67.0	45.0	55.0	5.10	21.7	14.3	15.4	79
0800	3	14	800	80.0	67.0	45.0	55.0	5.60	23.7	17.3	19.7	171
0800	4	14	800	80.0	67.0	45.0	55.0	6.40	27.1	19.0	22.9	171
1000	3	14	1000	80.0	67.0	45.0	55.0	7.40	31.4	22.3	18.9	213
1000	4	14	1000	80.0	67.0	45.0	55.0	8.50	36.0	24.6	16.5	213
1200	3	14	1200	80.0	67.0	45.0	55.0	8.30	35.2	25.7	20.4	348
1200	4	14	1200	80.0	67.0	45.0	55.0	9.60	40.8	28.5	18.9	348

AHRI Certification - Temspec vertical stack fan coil units are certified in compliance with Air-Conditioning, Heating, and Refrigeration Institute (AHRI) industry standard AHRI-440 for room fan coil units. Approved standard ratings are tabulated above.

C-ETL-US Listing - Temspec vertical stack fan coil units are listed by ETL. The C-ETL-US listing signifies that Temspec's fan coil units have been examined by ETL and are in compliance with both U.S. and Canadian applicable standards.



ETL LISTED
CONFORMS TO
UL STD 1995

CERTIFIED TO
CSA STD C22.2 NO. 236

Electric Heat

Available as a Primary or Auxiliary source of heat in a CW cooling unit

Located in reheat position relative to the cooling coil, after the supply fan

Single point power connection, single stage operation, with auto-reset high limit device

Model	Supply Voltage	Electric Heat kW															
		0.5	0.75	1.0	1.5	2.0	2.5	3.0	3.5	4.0	4.5	5.0	6.0	7.0	8.0		
0300 and 0400	120V/1/60	4.2	6.3	8.3	12.5	16.7											
	208V/1/60	2.4	3.6	4.8	7.2	9.6	12.0	14.4	16.8								
	240V/1/60			4.2	6.3	8.3	10.4	12.5	14.6								
	277V/1/60	1.8	2.7	3.6	5.4	7.2	9.0	10.8	12.6								
0600 and 0800	120V/1/60	4.2	6.3	8.3	12.5	16.7											
	208V/1/60	2.4	3.6	4.8	7.2	9.6	12.0	14.4	16.8	19.2	21.6	24.0	28.8				
	240V/1/60			4.2	6.3	8.3	10.4	12.5	14.6	16.7	18.8	20.8	25.0				
	277V/1/60	1.8	2.7	3.6	5.4	7.2	9.0	10.8	12.6	14.4	16.2	18.1	21.7				
1000 and 1200	120V/1/60	4.2	6.3	8.3	12.5	16.7											
	208V/1/60	2.4	3.6	4.8	7.2	9.6	12.0	14.4	16.8	19.2	21.6	24.0	28.8	33.7	38.5		
	240V/1/60			4.2	6.3	8.3	10.4	12.5	14.6	16.7	18.8	20.8	25.0	29.2	33.3		
	277V/1/60	1.8	2.7	3.6	5.4	7.2	9.0	10.8	12.6	14.4	16.2	18.1	21.7	25.3	28.9		

$$\text{Amps} = \frac{\text{Watts}}{\text{Volts}}$$

$$\text{MBH} = \text{kW} \times \frac{3160}{925}$$

$$\text{Air Temp. Rise (DeltaT)} = \frac{\text{kW} \times 3160}{\text{CFM}} = \frac{\text{MBH} \times 925}{\text{CFM}}$$

- SA = Supply Air
- FLA = Full Load Amps
- = SA fan motor amps + Electric heater amps
- MCA = Minimum Circuit Ampacity
- = FLA x 1.25
- MOP = Rating of maximum overcurrent protection device
- = (SA fan motor amps x 2.25) + Electric heater amps



Heating Capacities

1 and 2 Row Coils for 4 pipe units (140 thru 180 EWT)

All coils 14 fpi (12 fpi available) - Standard EAT of 70°F used

3 or 4 Row Coils for 2 pipe Heating only, Changeovers, or 4 pipe units w/6 Way Valve (110 and 120 EWT)

Model	Coil Rows	Air Flow (cfm)	EWT (F)	WPD (ft. H2O)	LWT (F)	Total Capacity (MBH)	WPD (ft. H2O)	LWT (F)	Total Capacity (MBH)	WPD (ft. H2O)	LWT (F)	Total Capacity (MBH)
300 and 400 cfm Models				1.0 gpm			2.0 gpm			3.0 gpm		
0300	3	300	110	0.6	94.9	7.5	2.3	100.7	9.2	5.0	103.3	10.0
0300	4	300	110	0.3	93.7	8.1	1.1	99.9	10.0	2.4	102.7	10.8
0400	3	400	110	0.6	93.1	8.3	2.3	99.1	10.8	5.0	102.0	11.9
0400	4	400	110	0.3	91.7	9.1	1.1	98.1	11.8	2.4	101.2	13.0
0300	3	300	120	0.6	101.0	9.4	2.3	108.3	11.6	4.9	111.5	12.5
0300	4	300	120	0.3	99.5	10.1	1.1	107.3	12.5	2.4	110.9	13.5
0400	3	400	120	0.6	98.7	10.5	2.3	106.3	13.5	4.9	109.9	14.9
0400	4	400	120	0.3	96.9	11.4	1.1	105.0	14.8	2.4	109.0	16.4
0300	1	300	140	1.5	122.0	8.9	5.6	129.5	10.3	12.0	132.6	10.9
0300	2	300	140	0.4	115.5	12.1	1.7	125.2	14.6	3.6	129.4	15.6
0400	1	400	140	1.5	120.1	9.8	5.6	128.2	11.6	12.0	131.6	12.4
0400	2	400	140	0.5	112.6	13.5	1.7	122.9	16.8	3.6	127.6	18.3
0300	1	300	160	1.5	136.5	11.5	5.5	146.4	13.3	11.8	150.4	14.1
0300	2	300	160	0.4	128.0	15.7	1.6	140.7	18.9	3.5	146.2	20.5
0400	1	400	160	1.5	133.9	12.7	5.5	144.6	15.0	11.8	149.1	16.0
0400	2	400	160	0.4	124.2	17.5	1.6	137.7	21.8	3.5	143.8	23.7
0300	1	300	180	1.4	150.8	14.2	5.3	163.2	16.4	11.5	168.2	17.3
0300	2	300	180	0.4	140.3	19.3	1.6	156.1	23.2	3.4	163.0	24.8
0400	1	400	180	1.5	147.7	15.7	5.3	161.0	18.5	11.5	166.5	19.7
0400	2	400	180	0.4	135.6	21.6	1.6	152.4	26.9	3.4	160.0	29.2
600 and 800 cfm Models				1.5 gpm			2.5 gpm			3.5 gpm		
0600	3	600	110	0.8	89.4	15.3	2.0	95.2	18.4	3.7	98.5	19.9
0600	4	600	110	0.5	87.6	16.6	1.3	93.7	20.1	2.5	97.4	21.8
0800	3	800	110	0.8	87.1	17.0	2.0	92.9	21.1	3.7	96.5	23.4
0800	4	800	110	0.5	85.1	18.5	1.3	91.2	23.3	2.5	95.1	25.8
0600	3	600	120	0.8	94.0	19.2	2.0	101.3	23.0	3.7	105.6	24.9
0600	4	600	120	0.5	91.8	20.9	1.3	99.6	25.2	2.4	104.2	27.3
0800	3	800	120	0.8	91.2	21.4	2.0	98.5	26.5	3.7	103.0	29.3
0800	4	800	120	0.5	88.7	23.2	1.3	96.4	29.2	2.4	101.2	32.4
0600	1	600	140	0.9	117.6	16.5	2.2	124.5	19.0	4.2	128.2	20.4
0600	2	600	140	1.4	107.8	23.7	3.7	117.2	28.0	7.0	122.5	30.2
0800	1	800	140	0.9	115.5	18.0	2.2	122.8	21.2	4.2	126.7	22.9
0800	2	800	140	1.4	104.3	26.3	3.7	114.0	31.9	7.0	119.7	35.0
0600	1	600	160	0.8	130.8	21.4	2.2	139.8	24.7	4.1	144.6	26.4
0600	2	600	160	1.4	118.2	30.7	3.6	130.4	36.2	6.8	137.2	39.0
0800	1	800	160	0.8	128.0	23.5	2.2	137.5	27.5	4.1	142.7	29.7
0800	2	800	160	1.4	113.5	34.1	3.6	126.2	41.3	6.8	133.6	45.2
0600	1	600	180	0.8	143.7	26.5	2.1	155.0	30.4	4.0	160.9	32.5
0600	2	600	180	1.4	128.4	37.6	3.5	143.5	44.4	6.6	151.9	47.8
0800	1	800	180	0.8	140.3	29.0	2.1	152.1	33.9	4.0	158.5	36.5
0800	2	800	180	1.4	122.6	41.8	3.5	138.3	50.7	6.6	147.4	55.5
1000 and 1200 cfm Models				2.5 gpm			3.5 gpm			4.5 gpm		
1000	3	1000	110	2.1	89.8	25.0	3.9	93.8	28.1	6.2	96.5	30.1
1000	4	1000	110	1.3	87.9	27.4	2.4	92.1	31.1	3.8	95.0	33.3
1200	3	1200	110	2.1	88.3	26.9	3.9	92.3	30.7	6.2	95.1	33.2
1200	4	1200	110	1.3	86.2	29.4	2.4	90.4	34.0	3.9	93.4	36.9
1000	3	1000	120	2.1	94.6	31.3	3.8	99.6	35.3	6.1	103.0	37.8
1000	4	1000	120	1.3	92.2	34.4	2.4	97.5	39.0	3.8	101.2	41.8
1200	3	1200	120	2.1	92.7	33.7	3.8	97.7	38.5	6.1	101.3	41.7
1200	4	1200	120	1.3	90.1	36.9	3.8	99.2	46.3	3.8	99.2	46.3
1000	1	1000	140	2.3	118.9	25.9	4.3	123.6	28.3	6.9	126.6	29.8
1000	2	1000	140	4.0	108.8	38.3	7.5	115.2	42.6	11.9	119.5	45.3
1200	1	1200	140	2.3	117.5	27.7	4.3	122.3	30.4	6.9	125.5	32.2
1200	2	1200	140	4.0	106.4	41.2	7.5	113.1	46.4	11.9	117.6	49.7
1000	1	1000	160	2.2	132.5	33.6	4.2	138.6	36.6	6.7	142.5	38.5
1000	2	1000	160	3.9	119.5	49.5	7.3	127.8	55.0	11.6	133.4	58.5
1200	1	1200	160	2.2	130.6	35.9	4.2	137.0	39.4	6.7	141.1	41.6
1200	2	1200	160	3.9	116.4	53.3	7.3	125.0	59.9	11.6	130.9	64.1
1000	1	1000	180	2.2	146.0	41.4	4.1	153.6	45.0	6.6	158.4	47.3
1000	2	1000	180	3.8	130.0	60.8	7.1	140.3	67.5	11.3	147.2	71.7
1200	1	1200	180	2.2	143.6	44.2	4.1	151.5	48.5	6.6	156.6	51.2
1200	2	1200	180	3.8	126.2	65.4	7.1	136.8	73.5	11.3	144.1	78.7

Temspec 4 pipe coils are in preheat. For humidity control, consider operating as a VAV. Run the fan at minimum cfm, and open the CW valve. This will wring the moisture out of the air, condensing on the coil. This is a more efficient use of fan energy, and not running HW to reheat. This also adds to the overall quiet performance of the unit, running at minimum cfm up to 66% of its operational time.

Backward Inclined Impeller Fan Performance

AHRI-440 Rated Data

Temspec uses BI fans with 0-10 VDC ECM's, a fan curve is not necessarily the best way to represent the data
The below charts show the relation of cfm to ESP, based on the volts supplied to the motor, up to 10% variance can occur

Model	ESP (" of W.C.)	Input Volts (0-10 vDC fan) - CFM achieved									
		1	2	3	4	5	6	7	8	9	10
0300 and 0400	0.0	31	70	121	170	207	257	321	362	406	454
	0.1				103	151	207	278	325	374	424
	0.2					96	167	240	287	335	387
	0.3						105	201	248	292	347
	0.4							161	214	256	314
	0.5							120	183	226	284

The recommended max ESP of a 0300 is 0.2" and for a 0400 is 0.25", while the fan can overcome higher ESP and achieve the approx. nominal cfm, the noise generated by the dominant noise path via the RA panel becomes objectionable as ESP rises. Units this size are typically serving a single space/room/zone, so consider how little duct work would need to be installed to reach the space relative to the unit location.

0600 and 0800	0.0	66	151	249	346	450	563	666	757	852	921
	0.1			139	259	385	513	620	723	814	872
	0.2				160	308	444	566	674	766	836
	0.3					197	358	500	618	724	796
	0.4						272	434	559	682	737
	0.5						177	354	498	626	700

The recommended max ESP of a 0600 is 0.3" and for a 0800 is 0.35", while the fan can overcome higher ESP and achieve the approx. nominal cfm, the noise generated by the dominant noise path via the RA panel becomes objectionable as ESP rises. Units in these sizes are often feeding more than one space/room/zone. While a larger amount of duct work can be accommodated to serve multiple spaces, consider the locating the unit at a central point to ensure all spaces are served.

1000 and 1200	0.0	149	243	398	564	747	909	1067	1210	1332	1373
	0.1		107	311	506	696	857	1037	1193	1320	1339
	0.2			189	418	641	816	1009	1157	1286	1311
	0.3				336	575	776	972	1130	1256	1277
	0.4				221	500	712	932	1088	1237	1269
	0.5					428	659	891	1054	1200	1241

The recommended max ESP of a 1000 is 0.4" and for a 1200 is 0.5", while the fan can overcome higher ESP and achieve the approx. nominal cfm, the noise generated by the dominant noise path via the RA panel becomes objectionable as ESP rises. Units in these sizes are often in large rooms, public and or industrial spaces. They can accommodate a large amount of duct work, however if a hotel or condo suite is so large to need 1,000 + cfm, consider two smaller units to serve the spaces better.

Backward Inclined Impeller Fan Motor

AHRI-440 Rated Data

All fans have an integral ECM which is 0-10 VDC, below find the nameplate data
Operational data of the actual watts consumed during testing of a free discharge installation

Model	Supply Voltage	Nameplate Data			FLA	MOP	Operational		
		Motor Type	Watts	Amps			Input Volts	CFM	Watts
0300	120V/1/60	ECM	85	1.3	1.6	15	5	207	14
	208-240V/1/60	ECM	80	0.7	0.9	15	6	257	21
	277V/1/60	ECM	80	0.7	0.9	15	7	321	29
0400	120V/1/60	ECM	85	1.3	1.6	15	7	321	29
	208-240V/1/60	ECM	80	0.7	0.9	15	8	362	46
	277V/1/60	ECM	80	0.7	0.9	15	9	406	60
0600	120V/1/60	ECM	165	2.3	2.9	15	5	450	32
	208-240V/1/60	ECM	168	1.4	1.8	15	6	563	50
	277V/1/60	ECM	168	1.4	1.8	15	7	666	73
0800	120V/1/60	ECM	165	2.3	2.9	15	7	666	74
	208-240V/1/60	ECM	168	1.4	1.8	15	8	757	107
	277V/1/60	ECM	168	1.4	1.8	15	9	852	142
1000	120V/1/60	ECM	345	3.0	3.8	15	5	747	88
	208-240V/1/60	ECM	500	2.5	3.1	15	6	909	147
	277V/1/60	ECM	500	2.5	3.1	15	7	1067	228
1200	120V/1/60	ECM	345	3.0	3.8	15	6	909	147
	208-240V/1/60	ECM	500	2.5	3.1	15	7	1067	228
	277V/1/60	ECM	500	2.5	3.1	15	8	1210	323

Temspec encourages taking full advantage of the 0-10 VDC fan control that the backward inclined impeller fans are equipped with out of the box, eschewing the traditional 3 speed control for vertical stack fan coil units. There are several advantages to this strategy:

1. Quieter operation - 0-10 VDC control will start at a minimum cfm, where 3 speed will start at High fan speed. The PI algorithm in the thermostat will try to maintain set point at the minimum cfm, only ramping up to a higher cfm when off set point. This can result in operating at minimum cfm up to 66% of the time.
2. Less Energy Consumed - running up to 66% of the time at minimum fan speed results in low annualized average watts consumed.
3. Dehumidification - with the fan at a minimum cfm, and the CW valve open, a large latent load will wring the moisture out of the air, condensing on the coil. No need for a more complex or energy inefficient reheat strategy.
4. Lower First Cost - Adding a 3 speed control board to a Temspec unit increases the sale price, and then robs the units of the previous three advantages.

Model	ESP (" of W.C.)	CFM	1/3 Octave Band Frequencies (Hz)								A-wt. (dBA)
			63	125	250	500	1000	2000	4000	8000	
0300 and 0400	0.0	175	59	58	44	40	35	29	27	32	36
	0.0	225	64	62	52	40	36	30	27	32	40
	0.0	300	67	63	50	44	39	35	29	32	41
	0.0	350	63	62	57	47	41	36	32	32	43
0600 and 0800	0.0	400	61	63	61	51	44	39	35	33	46
	0.0	400	66	65	47	42	36	31	27	32	42
	0.0	500	69	70	51	46	39	35	29	32	46
	0.0	600	68	74	56	50	43	38	32	32	50
1000 and 1200	0.0	700	65	75	59	52	45	41	34	32	51
	0.0	800	67	74	63	55	48	43	37	32	52
	0.0	600	64	68	53	48	44	36	28	32	45
	0.0	700	63	72	55	51	46	40	30	32	49
	0.0	800	65	73	58	54	48	43	33	32	50
	0.0	900	67	73	61	56	51	46	36	32	51
	0.0	1000	68	73	64	58	53	49	39	33	52
	0.0	1100	70	75	67	61	55	51	42	34	55
	0.0	1200	71	75	70	64	57	53	45	36	57

Model	ESP (" of W.C.)	CFM	1/3 Octave Band Frequencies (Hz)								A-wt. (dBA)
			63	125	250	500	1000	2000	4000	8000	
0300 and 0400	0.0	175	64	58	45	37	30	25	26	31	36
	0.0	225	66	56	50	40	34	27	26	31	37
	0.0	300	66	58	52	46	38	32	28	31	40
	0.0	350	67	61	56	49	40	33	29	31	42
0300 and 0400	0.0	400	68	59	64	53	43	34	32	32	48
	0.2	175	66	58	50	45	38	32	28	32	39
	0.2	225	68	61	52	47	38	32	28	32	41
	0.2	300	69	60	61	52	41	34	30	32	45
0600 and 0800	0.2	350	66	61	64	54	43	35	31	32	48
	0.2	400	67	61	65	56	46	37	34	33	49
	0.0	400	66	61	50	42	33	28	27	32	39
	0.0	500	65	62	52	44	35	29	28	32	40
0600 and 0800	0.0	600	68	65	57	48	38	32	29	32	44
	0.0	700	71	69	61	52	41	37	34	33	48
	0.0	800	70	68	64	55	43	37	34	33	49
	0.2	400	64	59	52	44	34	29	28	32	39
0600 and 0800	0.2	500	67	64	56	47	38	33	30	32	43
	0.2	600	68	67	60	50	41	36	32	33	46
	0.2	700	68	67	63	53	43	38	34	34	48
	0.2	800	72	68	68	58	45	40	37	35	52
1000 and 1200	0.0	600	68	63	49	43	36	29	27	32	41
	0.0	700	70	65	53	46	38	32	28	32	43
	0.0	800	69	65	57	50	41	34	30	32	45
	0.0	900	74	66	60	53	44	36	33	32	47
	0.0	1000	72	68	63	55	47	39	36	33	49
1000 and 1200	0.0	1100	74	70	66	58	50	42	39	35	52
	0.0	1200	75	70	68	61	52	45	42	37	53
	0.2	600	67	63	52	45	37	31	29	32	41
	0.2	700	69	65	56	49	40	33	30	32	44
	0.2	800	71	65	59	51	43	35	33	33	46
	0.2	900	74	67	62	54	46	38	35	33	48
	0.2	1000	73	70	65	57	48	40	37	34	51
0.2	1100	79	69	67	61	50	43	40	36	53	
	0.2	1200	77	70	71	62	53	46	43	38	55

Sound data was collected at VibroAcoustics Lab in Markham, ON, Canada in December 2017 and January 2018 - Consult factory for sound power values not listed
Maximum recommended ESP to achieve the nominal air flows of the 6 models, in order to reduce noise concerns are as follows:

T _{xx} 0300 = 0.20"	T _{xx} 0800 = 0.35"
T _{xx} 0400 = 0.25"	T _{xx} 1000 = 0.40"
T _{xx} 0600 = 0.30"	T _{xx} 1200 = 0.50"

While fans can overcome higher ESP, the sound levels out the dominant path (the RA) become objectionable. Consider options like: reducing the ESP by redesigning the duct work, locate the fan coil unit in a mechanical closet to separate the RA path, or use two smaller units to provide better zone control in the space.

The “L” in the TL series stands for “Leaf” as it is a more efficient, greener operation of a vertical stack fan coil unit. These units are the traditional concealed type, complete with a thru-the-wall RA access panel. Hidden behind drywall, either applied directly to the unit, or framed out around it, the only thing visible to the occupant is the RA panel, and any SA grilles. Ideal for condominiums, apartments, hotels, and dormitories, these units can be found in any multi-residential space that utilizes individual zone control.



Unit installation in a typical hotel room in Nashville, TN



*Variable Speed 250mm
Backward Inclined ECM
Impeller Fan*



*Variable Speed 310mm
Backward Inclined
ECM Impeller Fan*

Available in three cabinet sizes delivering a nominal 300 thru 1,200 cfm, and available as 2 pipe cooling only, heating only, changeover, auxiliary and primary electric heat, as well as 4 pipe variations.

The small cabinets, capable of a nominal 300 and 400 cfm are ideal for small, single zone spaces such as a typical hotel room, a single occupant dorm, or a studio to 1 bedroom apartment. These spaces are typically 250-400 sqft, with a single SA grille mounted on the unit, or a short duct-run to distribute the air to the space. These units can also find a home as the second unit in a larger suite, serving the primary bedroom in a larger apartment or hotel suite. This smaller unit creates a unique zone to be served separately from the rest of the space.

The medium size cabinet, capable of a nominal 600 and 800 cfm are found in larger suites, often pairing a unit mounted SA grille and a duct connection off the top to serve a

secondary space. Ideal for larger 2 bedroom apartments, or the corner suites of a hotel with higher solar exposure. Often tied to a space of similar square footage to the nominal cfm, a note of caution when assigned to much smaller spaces raising concerns about over cooling and/or noise when at maximum cfm. These units should be used for larger spaces with multiple zones to serve.

The large cabinet size, capable of a nominal 1,000 and 1,200 cfm are used much more sparingly. Ideal for larger common/public areas, rather than residential spaces. Sometimes even found in more industrial spaces such as an electrical and/or IDF room, where a cooling only unit is needed. Due to their higher cfm, they are often ducted off the top to deliver the larger volume of air to various spaces. These larger units can handle higher ESP, however, if noise is a concern, it is better to use two smaller units to serve the individual spaces, than just one large unit trying to feed them all.



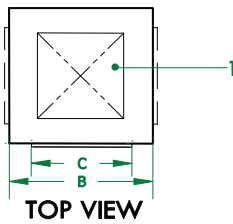

MODEL	A	B	C	E
TLA / TLE 0300	15.75"	15.75"	12"	52"
TLA / TLE 0400	15.75"	15.75"	12"	52"
TLA / TLE 0600	18"	20"	14"	52"
TLA / TLE 0800	18"	20"	14"	52"
TLA / TLE 1000	18"	24"	18"	54"
TLA / TLE 1200	18"	24"	18"	54"

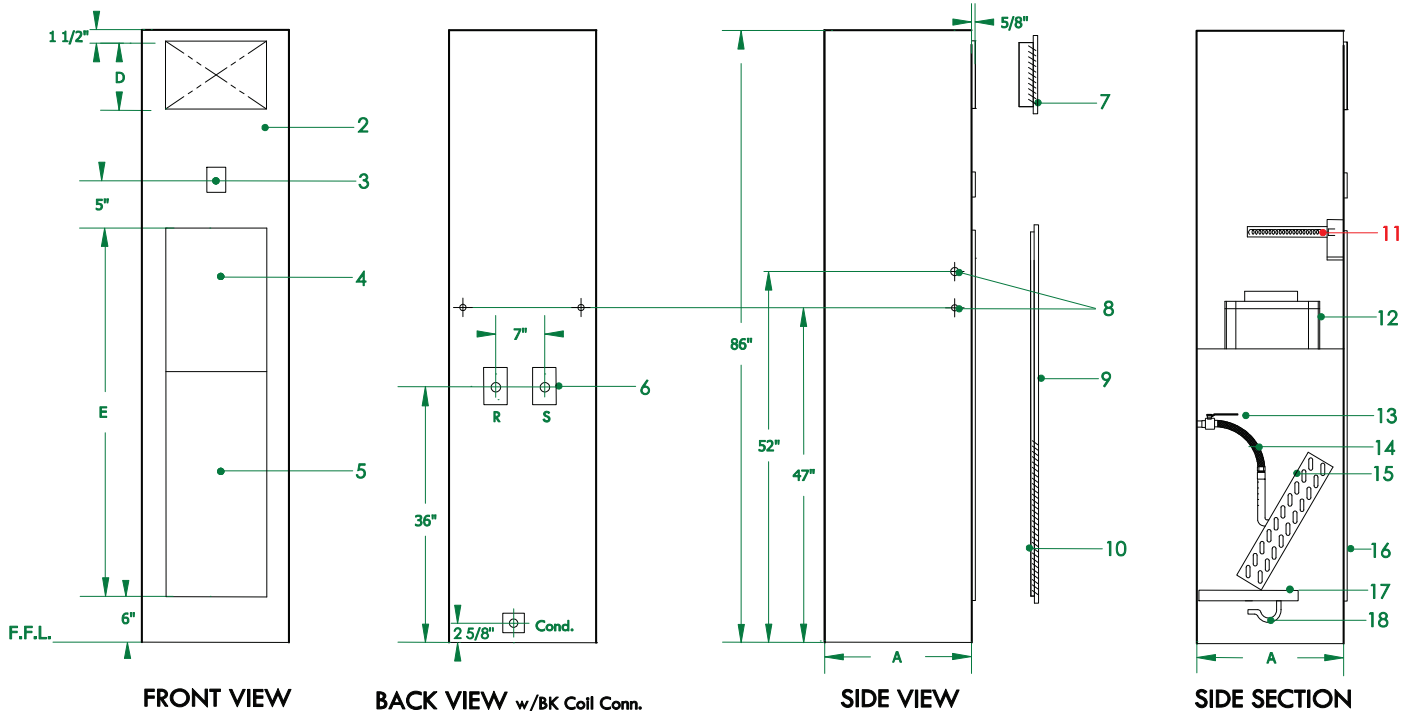

1. Top supply air opening (knock out) for attachment of ductwork
2. 20 ga steel cabinet, lined with 1" glass fiber insulation coated on the air side, 1/2" closed cell optional
3. Unit mounting location for thermostat/controller (Approx 60" AFF)
4. Fan shield acoustically lined. Identification and safety caution labels are affixed to this panel
5. Cardboard protective covering to prevent coils damage by debris, moisture etc. during shipping and installation
6. Vertical centerline of supply and return coil connection runouts. Connections can be at the back, left or right side of the unit
7. Double deflection steel supply air grille at the front, left, right or back or any combination when there are multiple openings. Dimension "D" varies with CFM: 6", 8", 10", 12" or 14"
8. 7/8" control exit hole at 47" on left, and back of cabinet. 1 3/8" power entry hole at 52" on right side of cabinet
9. Hinged return air grille/access panel
10. 1" disposable filter
11. Optional electric heater - turns a TLA into a TLE
12. EC motor, high-efficiency backward inclined impeller fan
13. Piping Package; typically includes isolation valve, control valve, strainer, balancing valve etc.
14. 12" stainless steel braided hose with proper 90 deg. bend. Using hose longer than 12" may cause kinking, affect the performance, or cause damage
15. Chilled water coil; hot water changeover optional
16. 5/8" flange on front of unit. Allows direct application of drywall to the unit
17. Polymer (0300 thru 0800) acrylic coated galvanized steel, or stainless-steel drain pan positively sloped in two di-rections towards the outlet
18. Drain hose from drain pan to condensate riser. The flexible hose forms a running P-trap

MODEL	A	B	C	E
TLS 0300	15.75"	15.75"	12"	52"
TLS 0400	15.75"	15.75"	12"	52"
TLS 0600	18"	20"	14"	52"
TLS 0800	18"	20"	14"	52"
TLS 1000	18"	24"	18"	54"
TLS 1200	18"	24"	18"	54"

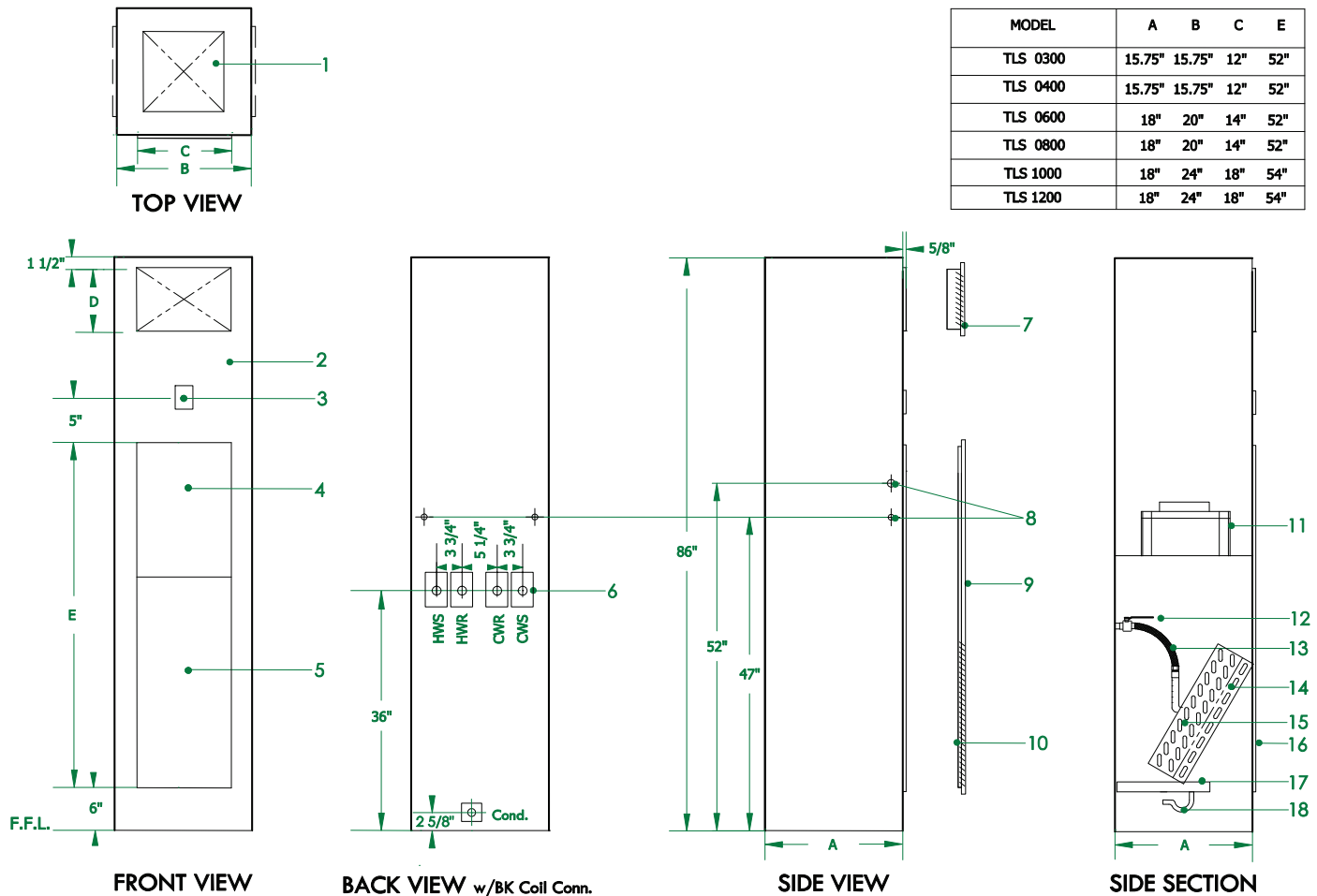

- Top supply air opening (knock out) for attachment of ductwork
- 20 ga steel cabinet, lined with 1" glass fiber insulation coated on the air side, 1/2" closed cell optional
- Unit mounting location for thermostat/controller (Approx 60" AFF)
- Fan shield acoustically lined. Identification and safety caution labels are affixed to this panel
- Cardboard protective covering to prevent coils damage by debris, moisture etc. during shipping and installation
- Vertical centerline of supply and return coil connection runouts. Connections can be at the back, left or right side of the unit
- Double deflection steel supply air grille at the front, left, right or back or any combination when there are multiple openings. Dimension "D" varies with CFM: 6", 8", 10", 12" or 14"
- 7/8" control exit hole at 47" on left, and back of cabinet. 1 3/8" power entry hole at 52" on right side of cabinet
- Hinged return air grille/access panel
- 1" disposable filter
- EC motor, high-efficiency backward inclined impeller fan
- Piping Package; typically includes isolation valve, control valves, strainer, balancing valve etc.
- 12" stainless steel braided hose with proper 90 deg. bend. Using hose longer than 12" may cause kinking, affect the performance, or cause damage
- Hot water coil
- Chilled water coil
- 5/8" flange on front of unit. Allows direct application of drywall to the unit
- Polymer (0300 thru 0800), acrylic coated galvanized steel, or stainless-steel drain pan positively sloped in two directions towards the outlet
- Drain hose from drain pan to condensate riser. The flexible hose forms a running P-trap

A variation on the TL series, we removed the SA plenum (the top 16") from the unit. The result is a 70" tall version that is ideal of installation in a mechanical closet, hence the "M" in the TM series. The same cabinet footprints, nominal cfms, heating and cooling options, just a shorter, 100% ducted SA unit.

Installation in a mechanical closet has proven to be most popular in new suite style dormitories. The mechanical closet as accessed from the hallway, while a transfer grille allows RA into the closet from the suite. The closet acts as a supply plenum (you can even dump OA from your DOAS into the closet) and it is sucked up into the unit, and distributed to typical 2, 3, or even 4 individual bedrooms in the suite style dorm. This also improves the noise levels due to the lengthened path of the RA from the fan in the unit to the space. There are three variations of the application of the TM series units:

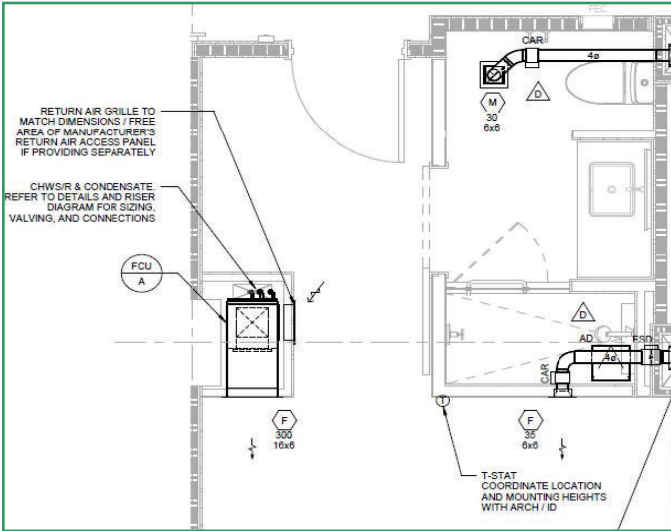

Figure 1: Hotel with low ceiling, ducted supply, and front return

Figure 1: The first, is a concealed behind drywall version, this unit being complete with a thru-the-wall access panel (Hinged/louvered or Perimeter), just in the 70" cabinet for a 100% ducted SA. Most common when a low ceiling will not allow to turn a duct off an 86" tall TL series unit, the 70" option allows more room and options to run your duct-work. This has been provided for some luxury hotels.

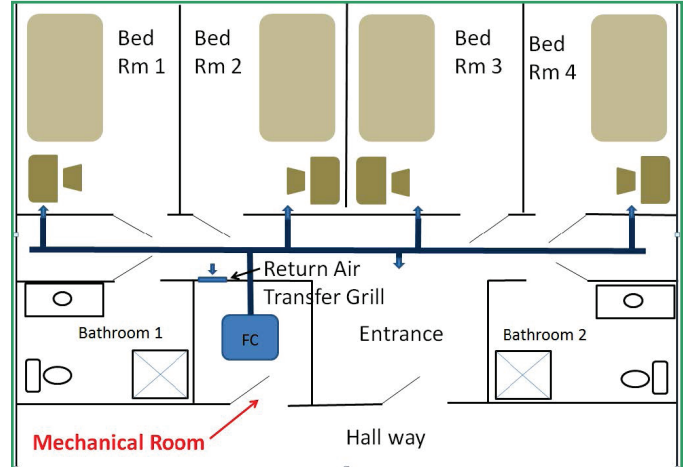

Figure 2: Dormitory with mechanical closet and plenum return

Figure 2: The second option is the most common, where the unit sits in a mechanical closet, and the closet is used as an RA plenum as described earlier. In these cases, no thru-the-wall access panel is provided, the filter mounts on a channel flange on the front of the unit to ensure all the air in the closet passes through the filter. This makes the TM version of a unit roughly 90% of the cost of a similar TL unit, by removing the upper SA plenum, the RA panel, and any SA grilles. The transfer grille to the closet is provided by others, and can be in the wall, up through the ceiling, or in the closet door itself.

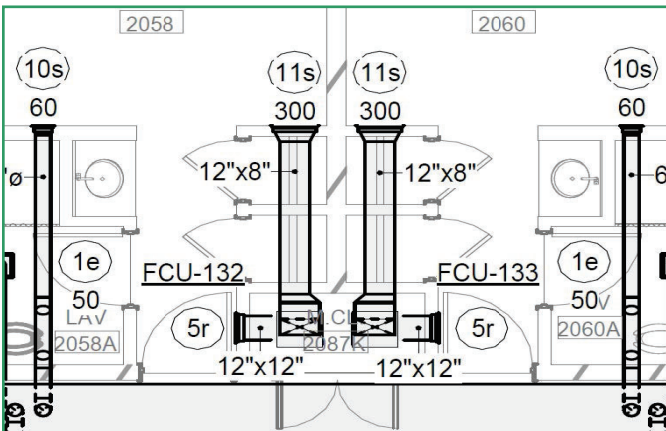
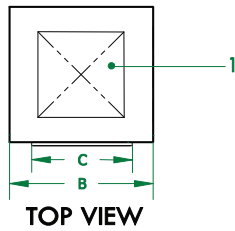
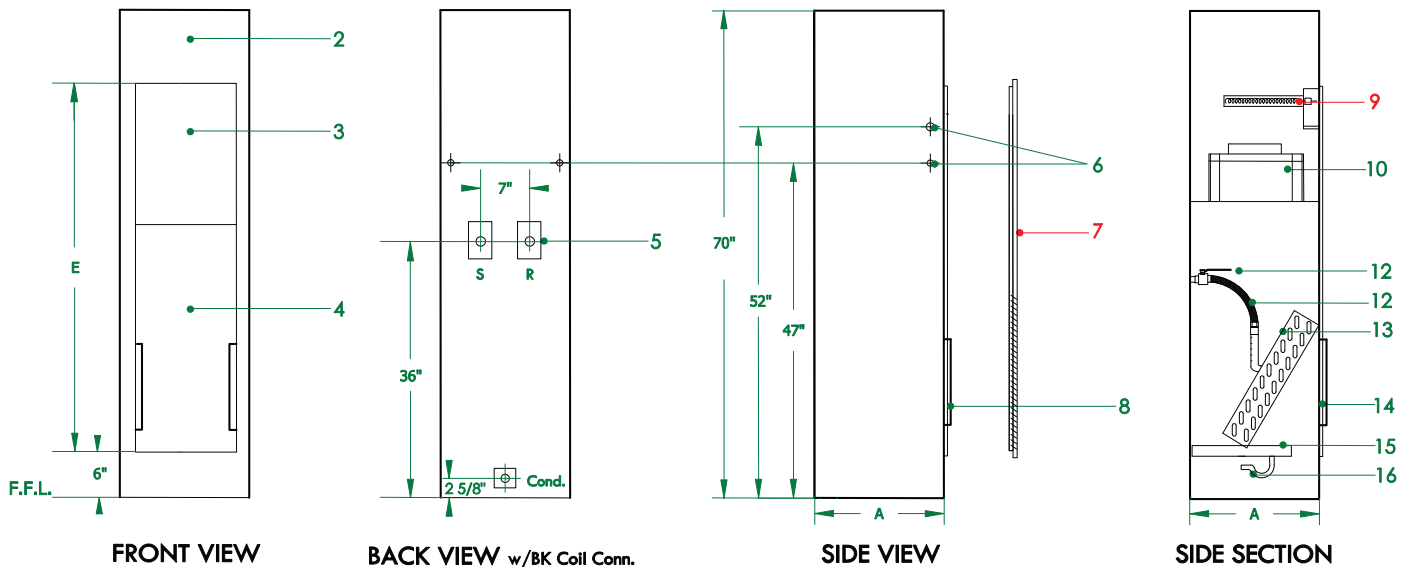

Figure 3: Dormitory with mechanical closet and ducted return

Figure 3: The third option is to duct the RA directly into the bottom of the unit. Still installed into a mechanical closet, but when using the closet as a plenum is not desirable. In these cases, the interior components are moved up in the cabinet to raise the bottom of the drain pan from the standard 6" from the bottom of the cabinet, to 10". This allows for a left, right, or back opening on the cabinet to connect an RA duct. The opening is 14" x 8" on the small cabinet units, and 16" x 8" for the medium and large size cabinets. The filter is relocated to mount on the face of the coil, and a special panel is provided to block-off the standard RA path on the front of the unit. This unique application has been used most frequently on military barracks. It is important to limit the length of the RA duct run, while the fans can overcome a great deal of static, vertical stack fan coil units primary design is not to handle high ESP on both the return and the supply.



MODEL	A	B	C	E
TMA / TME 0300	15.75"	15.75"	12"	52"
TMA / TME 0400	15.75"	15.75"	12"	52"
TMA / TME 0600	18"	20"	14"	52"
TMA / TME 0800	18"	20"	14"	52"
TMA / TME 1000	18"	24"	18"	54"
TMA / TME 1200	18"	24"	18"	54"



1. Top supply air opening (knock out) for attachment of ductwork
2. 20 ga steel cabinet, lined with 1" glass fiber insulation coated on air side, 1/2" closed cell optional
3. Fan shield acoustically lined. Identification and safety caution labels are affixed to this panel
4. Cardboard protective covering to prevent coil damage by debris, moisture etc. during installation and shipping
5. Vertical centerline of supply and return coil connection run outs. Connection can be at the back, left, or right side of the unit
6. 7/8" control exit hole at 47" on left, and back of cabinet. 1 3/8" power entry hole at 52" on right side of cabinet
7. Optional Hinged thru-the-wall return air/access panel
8. 1" disposable filter on the filter rack on the face of the unit when the unit sits in a mechanical closet and no RA Panel is supplied
9. Optional electric heater - turns a TMA into a TME
10. EC motor, high-efficiency backward inclined impeller fan
11. Piping package; typically includes Isolation valve, control valve, strainer, balancing valve etc.
12. 12" stainless steel braided hose with proper 90 deg. bend. Using hose longer than 12" may cause kinking, affect the performance, or cause damage
13. Chilled water coil / Hot water changeover coil
14. 1" filter rack on front of unit. Allows filter to mount on the front of the unit (not provided if thru-the-wall return air grille/access panel is provided)
15. Polymer (0300 thru 0800), acrylic coated galvanized steel, or stainless-steel drain pan positively sloped in two directions towards the outlet
16. Drain hose from drain pipe to condensate riser. The flexible hose forms a running P-trap

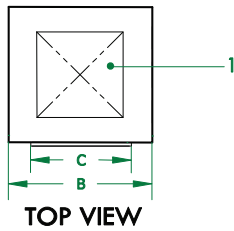

MODEL	A	B	C	E
TMS 0300	15.75"	15.75"	12"	52"
TMS 0400	15.75"	15.75"	12"	52"
TMS 0600	18"	20"	14"	52"
TMS 0800	18"	20"	14"	52"
TMS 1000	18"	24"	18"	54"
TMS 1200	18"	24"	18"	54"

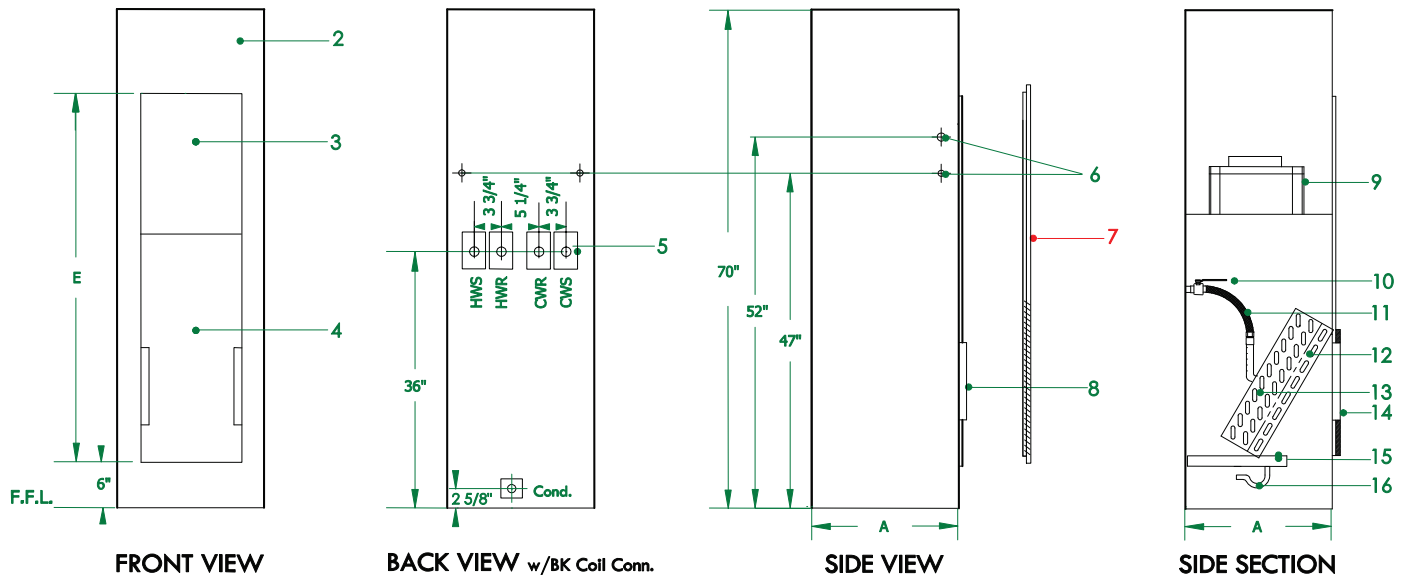

1. Top supply air opening (knock out) for attachment of ductwork
2. 20 ga steel cabinet, lined with 1" glass fiber insulation coated on air side, 1/2" closed cell optional
3. Fan shield acoustically lined. Identification and safety caution labels are affixed to this panel
4. Cardboard protective covering to prevent coil damage by debris, moisture etc. during installation and shipping
5. Vertical centerline of supply and return coil connection run outs. Connection can be at the back, left, or right side of the unit
6. 7/8" control exit hole at 47" on left, and back of cabinet. 1 3/8" power entry hole at 52" on right side of cabinet
7. Optional Hinged thru-the-wall return air/access panel
8. 1" disposable filter on the filter rack on the face of the unit when the unit sits in a mechanical closet and no RA Panel is supplied
9. EC motor, high-efficiency backward inclined impeller fan
10. Piping package; typically includes Isolation valve, control valve, strainer, balancing valve etc.
11. 12" stainless steel braided hose with proper 90 deg. bend. Using hose longer than 12" may cause kinking, affect the performance, or cause damage
12. Hot water coil
13. Chilled water coil
14. 1" filter rack on front of unit. Allows filter to mount on the front of the unit. (not provided if thru-the-wall return air grille/access panel is provided)
15. Polymer (0300 thru 0800), acrylic coated galvanized steel, or stainless-steel drain pan positively sloped in two directions towards the outlet
16. Drain hose from drain pipe to condensate riser. The flexible hose forms a running P-trap



A Model TF Finished Cabinet

The “F” in the TF series comes from the Finished cabinet provided. Unlike the TL and TM series, the TF series feature a fully painted cabinet that can be installed directly in the space. Most frequently used in older style dormitories that do not have drywall, they are also found in the more industrial spaces noted for 1,000 and 1,200 cfm units. These tend to be more public spaces, like classrooms or offices, rather than residential spaces.

The same nominal cfm, heating, and cooling options, as well as three different cabinet sizes. The cabinets themselves are slightly larger, and more robust, to handle the wear and tear of being exposed out in the space. Whether it is students throwing their bags, or backing a chair into them, they are made to handle more punishment.

Available in three standard color options (Off-White, Light Grey, and Beige) custom colors can be provided for an additional fee.

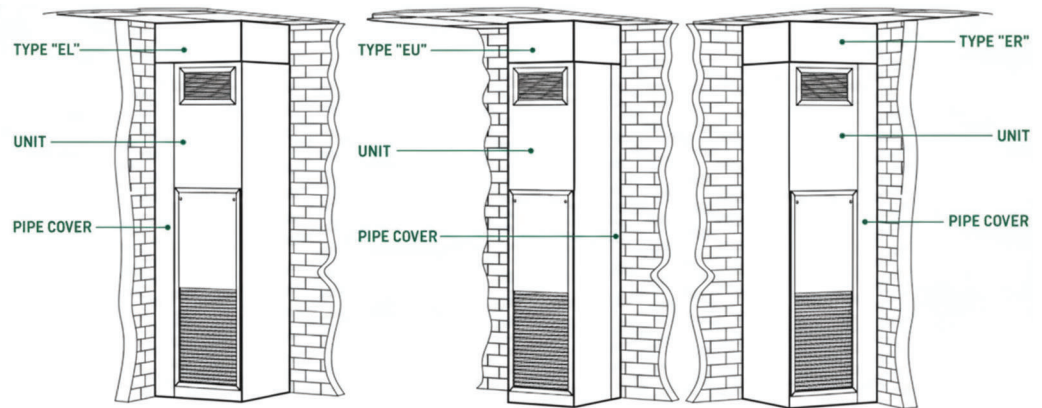

The units being exposed, do not have the luxury of concealing the pipes and power connections coming in and out of the units. Because of this, additional sheet-metal accessories are typically included with TF series units.

Top Extensions, fill the gap between the top of the unit and the ceiling (often a drop ceiling). The extensions conceal the power and control wiring that enters/exits through the top of the unit, any ductwork that may come off the unit, as well as prevent occupants disturbing this space. Usually provided as a two- or three-sided sheet-metal piece, as units are up against a wall, or in a corner. This piece is painted with the same finish as the cabinet and often shipped after the units are installed when an exact measurement can be made to fabricate the piece correctly for the space. An additional 1 1/2” is added to the height of the extension so they can overlap the top of the unit to be secured to the cabinet.

One, Two, and Three-Sided Pipe Cover/Block-Off Options

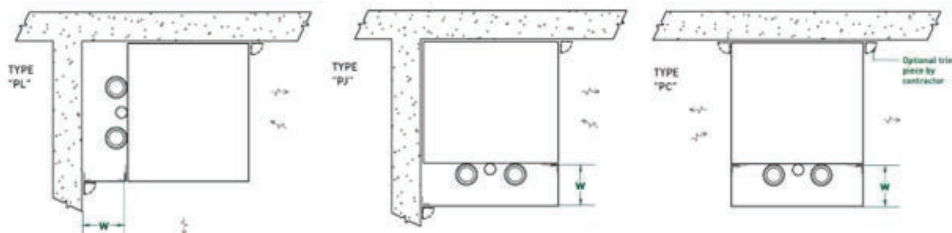

Pipe Covers and/or Block-Off Panels are provided to conceal the risers, or any space between the unit and the wall. Most often these pieces are one sided, and the same height of the cabinet, but can be also two- or three-sided if the pipes are on an exposed side. Same as the top extension, finished in the same color as the cabinet, and provided when accurate dimensions are received to fabricate.

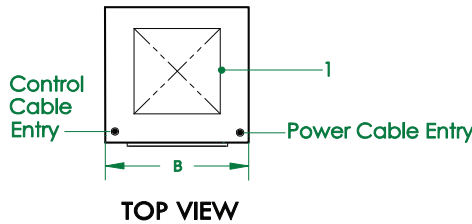

MODEL	A	B
TFA / TFE 0300	18"	18"
TFA / TFE 0400	18"	18"
TFA / TFE 0600	20"	20"
TFA / TFE 0800	20"	20"
TFA / TFE 1000	20"	24"
TFA / TFE 1200	20"	24"

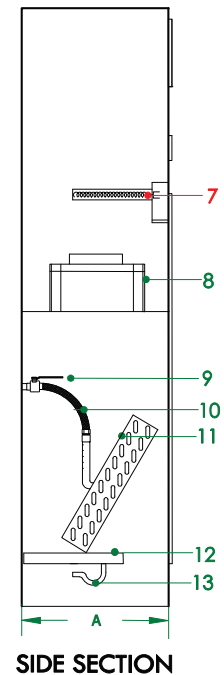
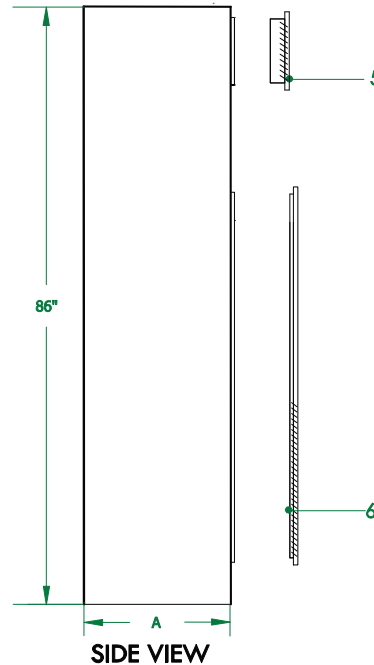
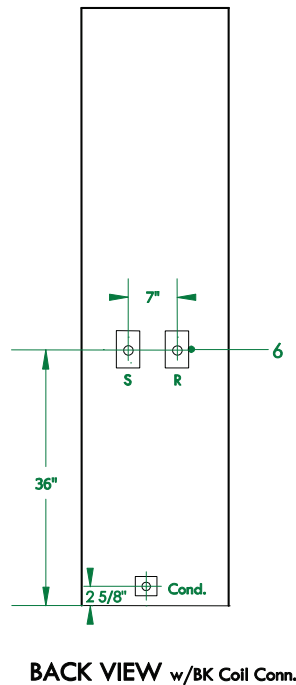
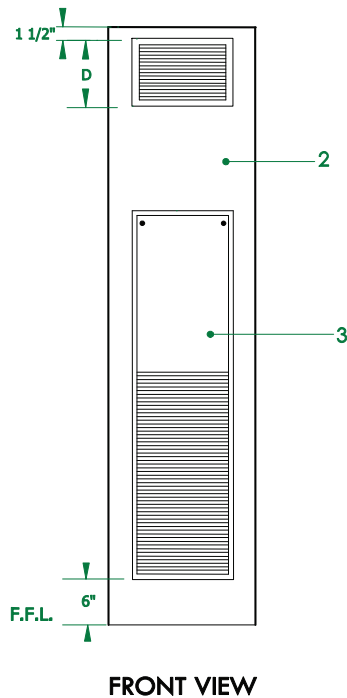

1. Top supply air opening (knock out) for attachment of ductwork
2. 18 ga steel fully painted cabinet, lined with 1" glass fiber insulation coated on air side, 1/2" closed cell optional standard color options are off-white, light gray, or beige
3. Removable access panel incorporating return air grille w/ quick release screws
4. Vertical centerline of supply and return coil connection run outs. Connection can be at the back, left, or right side of the unit
5. Double deflection steel supply grille at the front, left, right, or back or any combination when there are multiple openings. Dimension "D" varies with CFM: 5", 6", 8", 10", 12" or 14"
6. 1" disposable filter
7. Optional electric heater - turns a TFA into a TFE
8. EC motor, high-efficiency backward inclined impeller fan
9. Piping package; typically include isolation valve, control valve, strainer, balancing valve etc.
10. 12" stainless steel braided hose with proper 90 deg. bend.
11. Chilled water coil, hot water changeover coil optional
12. Acrylic coated galvanised steel, or stainless-steel drain pan positively sloped in two directions towards the outlet
13. Drain hose from drain pipe to condensate riser
The flexible hose forms a running P-trap

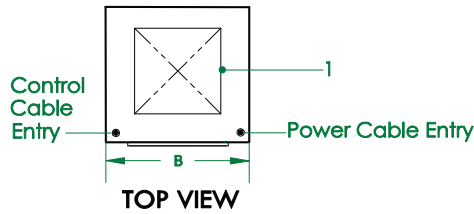

MODEL	A	B
TFS 0300	18"	18"
TFS 0400	18"	18"
TFS 0600	20"	20"
TFS 0800	20"	20"
TFS 1000	20"	24"
TFS 1200	20"	24"

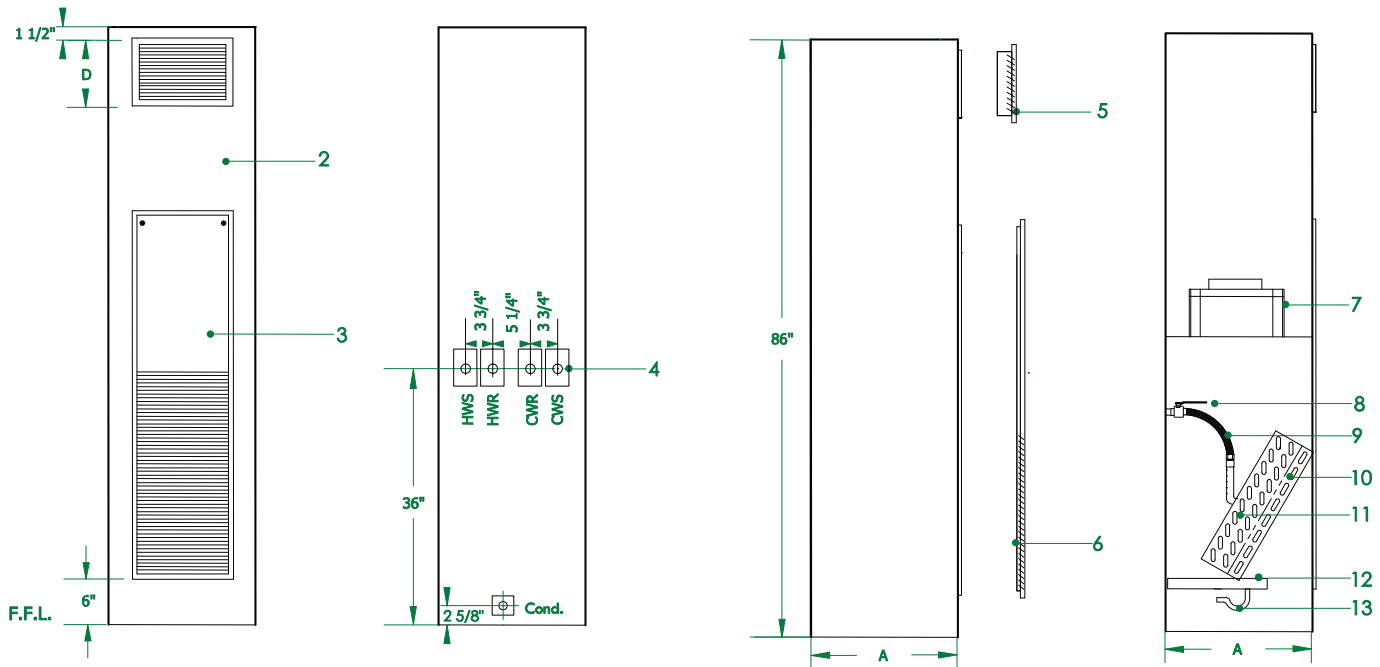

1. Top supply air opening (knock out) for attachment of ductwork
2. 18 ga steel fully painted cabinet, lined with 1" glass fiber insulation coated on air side, 1/2" closed cell optional. Standard color options are off-white, light gray, or beige
3. Removable access panel incorporating return air grille w/ quick release screws
4. Vertical centerline of supply and return coil connection run out. Connection can be at the back, left, or right side of the unit
5. Double deflection steel supply grille at the front, left, right, or back or any combination when there are multiple openings. Dimension "D" varies with CFM: 5", 6", 8", 10", 12" or 14"
6. 1" disposable filter
7. EC motor, high-efficiency backward inclined impeller fan
8. Piping package; typically include isolation valve, control valve, strainer, balancing valve etc.
9. 12" stainless steel braided hose with proper 90 deg. bend. Using hose longer than 12" may cause kinking, affect the performance, or cause damage
10. Chilled water coil
11. Hot water coil
12. Acrylic coated galvanised steel, or stainless-steel drain pan positively sloped in two directions towards the outlet
13. Drain hose from drain pipe to condensate riser. The flexible hose forms a running P-trap

The latest offering from Temspec, takes our TL series of units and adds an integral HRV/ERV recovery module inside the unit cabinet. Most common in new construction applications in condominiums and apartments, like the TL series these units are concealed behind drywall, with only their RA/access panel visible in the space.

Just as our use of backward inclined impeller fans with integral ECM's reduced the amount of energy that our units consume, when designing our HRV/ERV module, we wanted to ensure that we were recovering more energy and using less energy to achieve that. Our counterflow cores recover almost 50% more energy, while the BI fans combine to use half the energy than that of other manufacturers. The result is over 2.5x the energy recovered. The module is capable of a max air flow of 100 cfm @ 0.5" ESP.

Available in two cabinet sizes and six nominal CFMs, as well as the same 2 and 4 pipe variations offered in our other series. The recovery module itself can be located on the left, right, or back side of the cabinet, to aid in the routing of the duct work that is connected to the unit. A large perimeter style RA panel is provided to allow access to all the internal components and provide a nice modern finish in the suite. TR series units are 100% ducted SA off the top of the unit. Each unit includes a bathroom timer "boost" switch that can be tied to the unit.

Recovery Core Effectiveness

Summer OA 87/70.9 and RA 75/63

Winter OA -12/-12.9 and RA 70/58.1

Max air flow 100cfm @ 0.5" ESP - verified by 3rd party

Airflow (cfm)	HRV				ERV					
	Summer		Winter		Summer			Winter		
	SRE	TRE	SRE	TRE	SRE	LRE	TRE	SRE	LRE	TRE
25	90.2	42.9	91.7	65.5	82.3	63.7	72.6	83.0	70.0	79.3
50	87.4	41.5	88.8	63.4	75.6	51.8	63.2	76.2	59.7	71.5
75	84.5	40.2	85.6	61.2	70.7	44.7	57.1	71.2	53.0	66.1
100	82.8	39.3	83.8	59.9	66.5	39.4	52.4	66.9	48.0	61.5

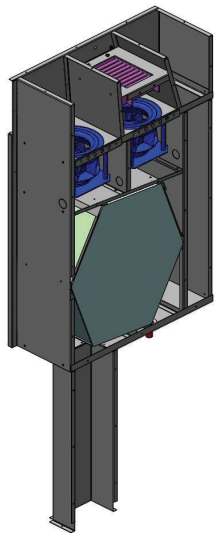

Counterflow Core



Fresh/Outside & Exhaust Air ECM Fans

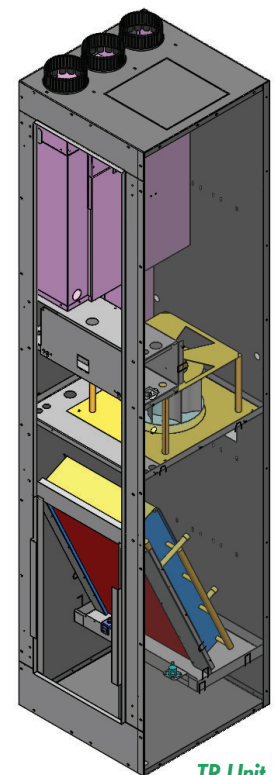

TR Unit

TR Recovery Module

TR Series - Electrical Data

Two additional fans are included in each recovery module

Optional 0.2 KW electric heater available for core frost protection

Model	Supply Voltage	Nameplate Data			Module Fan Amps (2 fans)	MCA without module heater	MCA with module heater
		Motor Type	Watts	Amps			
0300 and 0400	120V/1/60	ECM	85	1.30	1.20	4.03	6.71
0300 and 0400	208-240V/1/60	ECM	80	0.70	0.60	2.08	3.58
0300 and 0400	277V/1/60	ECM	80	0.72	1.26	2.17	4.07
0600 and 0800	120V/1/60	ECM	165	2.30	1.20	5.28	7.96
0600 and 0800	208-240V/1/60	ECM	168	1.40	0.60	2.95	4.46
0600 and 0800	277V/1/60	ECM	168	1.26	1.26	2.85	4.74
1000 and 1200	120V/1/60	ECM	345	3.00	1.20	6.15	8.84
1000 and 1200	208-240V/1/60	ECM	500	2.50	0.60	4.33	5.83
1000 and 1200	277V/1/60	ECM	500	2.50	1.26	4.39	6.29

A small 0.2 KW electric heater is an available option to include in the recovery module for additional core frost protection if cycling the exhaust fan is not enough.

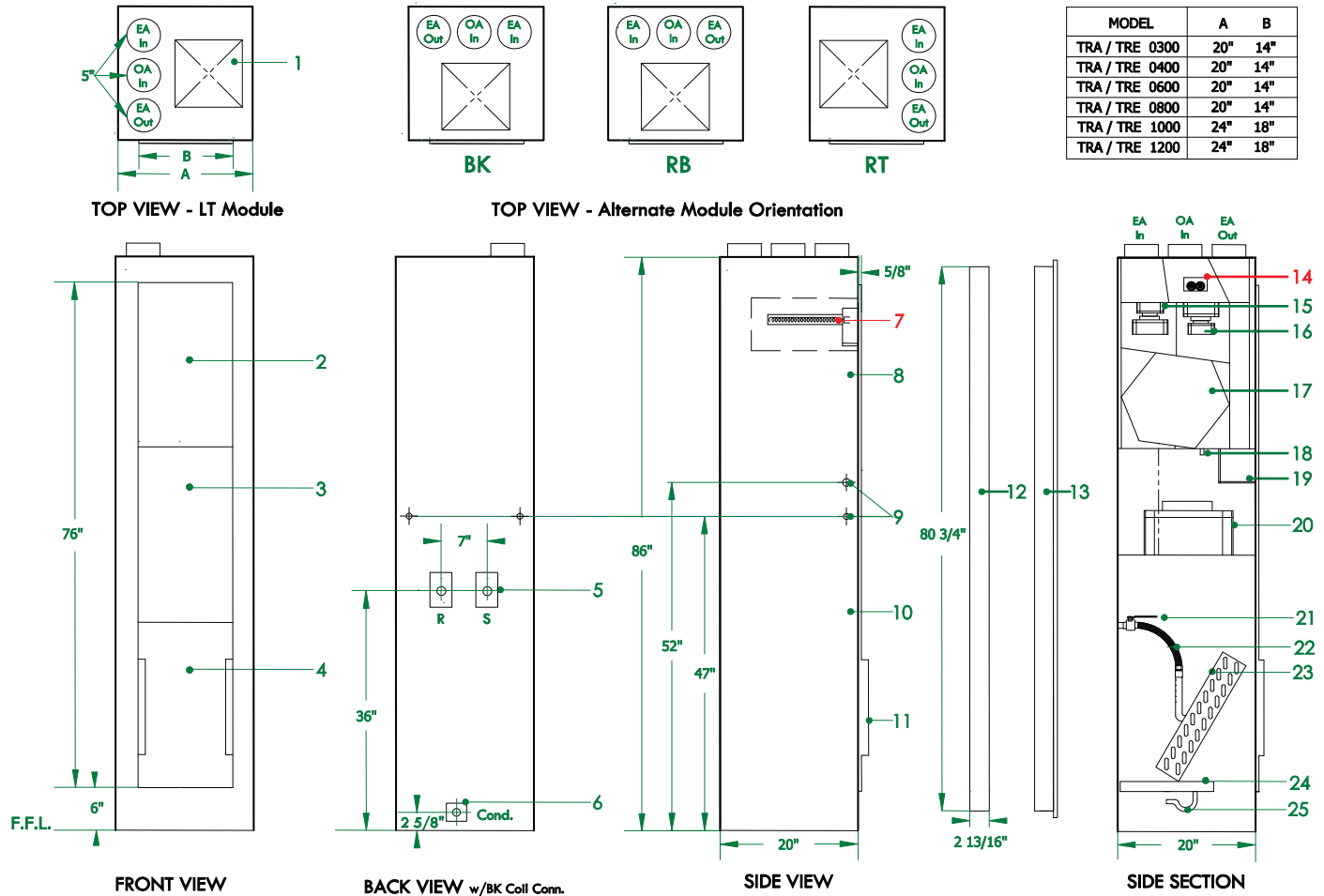

1. Top supply air opening (knock out) for attachment of ductwork
2. Module/SA plenum access panel
3. Fan shield acoustically lined. Identification and safety caution labels are affixed to this panel
4. Cardboard protective covering to prevent coils damage by debris, moisture etc. during shipping and installation
5. Vertical centerline of supply and return coil connection runouts. Connections can be at the back, left, or right side of the unit
6. Condensate/drain connection from drain pan to riser
7. Optional electric heater - turns a TRA into a TRE
8. ERV/HRV module, inside cabinet SA plenum
9. 7/8" control exit hole at 47" on left, and back of cabinet.
1 3/8" power entry hole at 52" on right side of cabinet
10. 20 ga steel cabinet, lined with 1/2" closed cell insulation
11. 1" channel flange to retain 1" disposable filter
12. Mounting collar for perimeter type RA panel (shipped loose)
13. Perimeter type, hinged RA access panel - allows easy access to change filters, and remove access panels for unit maintenance
14. Optional 0.2 KW electric heater in module for core frost protection
15. Exhaust air fan
16. Outside/fresh air fan
17. Counterflow ERV or HRV core
18. Condensate drain - connected to unit drain pan
19. Electrical compartment
20. EC motor, high efficiency backward inclined impeller fan
21. Piping Package; typically includes isolation valve, control valve, strainer, balancing valve etc.
22. 12" stainless steel braided hose with proper 90 deg. bend. Using hose longer than 12" may cause kinking, affect the performance, or cause damage
23. Chilled water coil, hot water changeover coil optional
24. Acrylic coated galvanized steel, or stainless-steel drain pan positively sloped in two directions towards the outlet
25. Drain hose from drain pan to condensate riser. The flexible hose forms a running P-trap

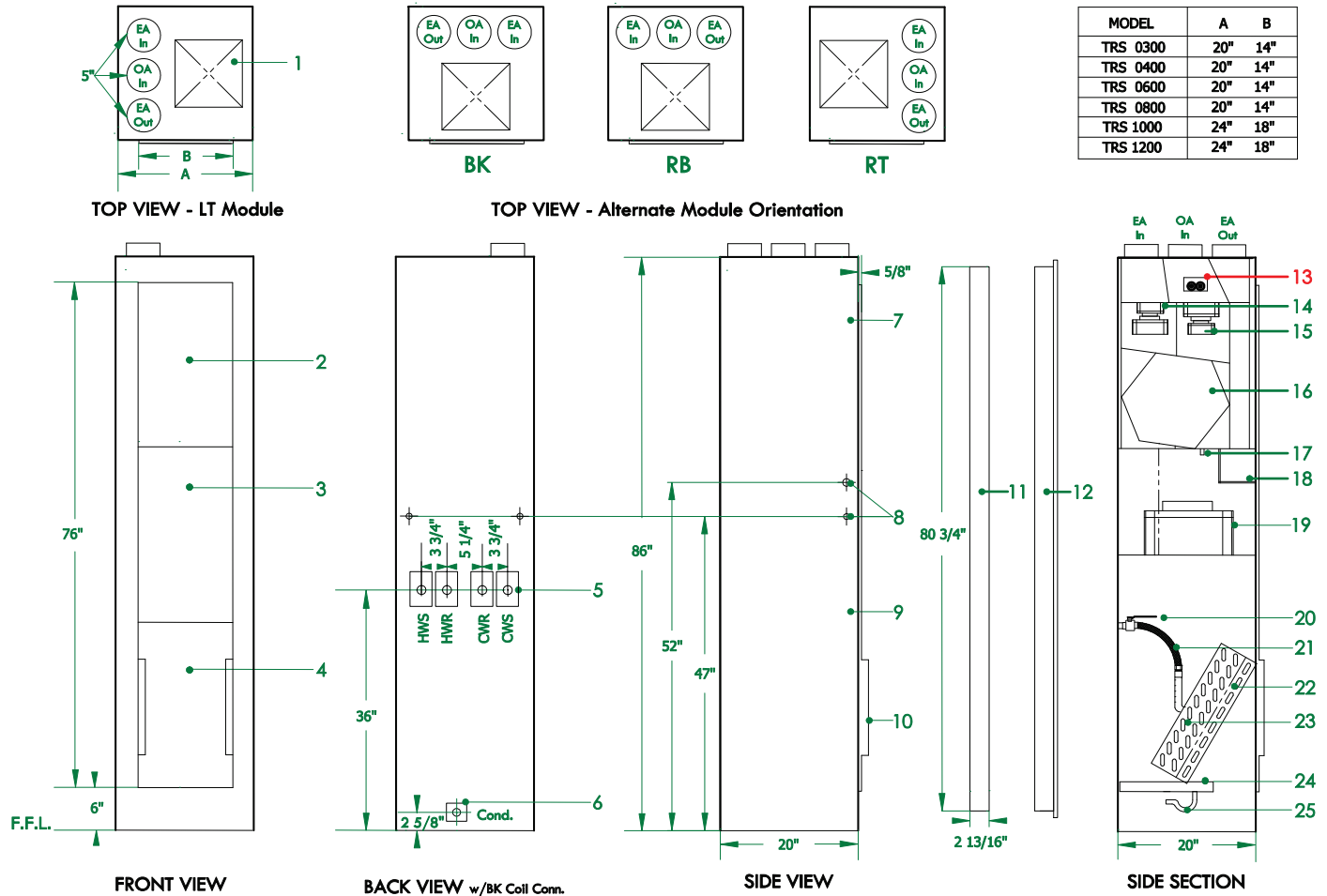

1. Top supply air opening (knock out) for attachment of ductwork
2. Module/SA plenum access panel
3. Fan shield acoustically lined. Identification and safety caution labels are affixed to this panel
4. Cardboard protective covering to prevent coils damage by debris, moisture etc. during shipping and installation
5. Vertical centerline of supply and return coil connection runouts. Connections can be at the back, left, or right side of the unit
6. Condensate/drain connection from drain pan to riser
7. ERV/HRV module, inside cabinet SA plenum
8. 7/8" control exit hole at 47" on left, and back of cabinet.
1 3/8" power entry hole at 52" on right side of cabinet
9. 20 ga steel cabinet, lined with 1/2" closed cell insulation
10. 1" channel flange to retain 1" disposable filter
11. Mounting collar for perimeter type RA panel (shipped loose)
12. Perimeter type, hinged RA access panel - allows easy access to change filters, and remove access panels for unit maintenance
13. Optional 0.2 KW electric heater in module for core frost protection
14. Exhaust air fan
15. Outside/fresh air fan
16. Counterflow ERV or HRV core
17. Condensate drain - connected to unit drain pan
18. Electrical compartment
19. EC motor, high efficiency backward inclined impeller fan
20. Piping Package; typically includes isolation valve, control valve, strainer, balancing valve etc.
21. 12" stainless steel braided hose with proper 90 deg. bend. Using hose longer than 12" may cause kinking, affect the performance, or cause damage
22. Hot water coil (alt. 2 pipe coil w/6way valve for low grade heat application)
23. Chilled water coil
24. Acrylic coated galvanized steel, or stainless-steel drain pan positively sloped in two directions towards the outlet
25. Drain hose from drain pan to condensate riser. The flexible hose forms a running P-trap

Return Air Access Panels

Vertical Stack Fan Coil Units are typically concealed behind drywall. A thru-the-wall access panel allows access to the internal of the unit for maintenance. Drywall can either be applied directly to the face of the unit, or framed out in front of it.

Standard Hinged RA Panel

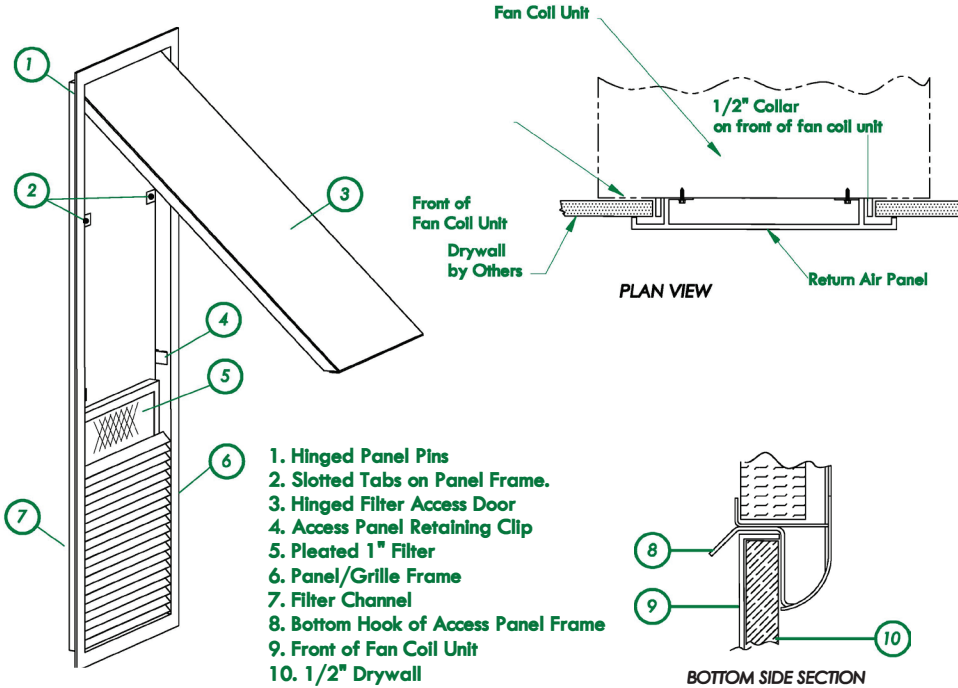

Sequence of Installation by the contractor:

- Drywall must be secured directly to the front of the unit.
- Remove the two hex-head machine screws (size #8-32) from the motor cover on the unit (the top pair of the 4 screws on the motor cover).
- Remove the hinged door from the access panel by lifting it 90 degrees and sliding it out.
- Hook the access panel over the bottom collar of the fan coil unit, tilt the panel up so that it is flush against the wall.
- Secure the panel to the unit with the previously removed machine screws by inserting the screws through the slotted tabs on the panel frame.
- Install the filter by sliding it vertically down behind the louvered section.
- Re-Install the hinged panel by holding it horizontally, sliding it in and over the pins on the frame, then lower it to close the panel.

Upgrade - Perimeter RA Panel

Sequence of Installation by the contractor:

- if the drywall has not been installed flush with the outer edge of the collar on the unit, and if the gap between inner surface of the drywall and the outer edge of the collar exceeds 1/2", the opening will have to be sleeved
- Insert the return air panel into the 2.813" deep collar on the fan coil unit so that the panel frame is against the drywall
- Open the hinged access panel and secure the frame by fitting six sheet metal screws as shown. Do not over tighten the screws
- Close the hinged access panel

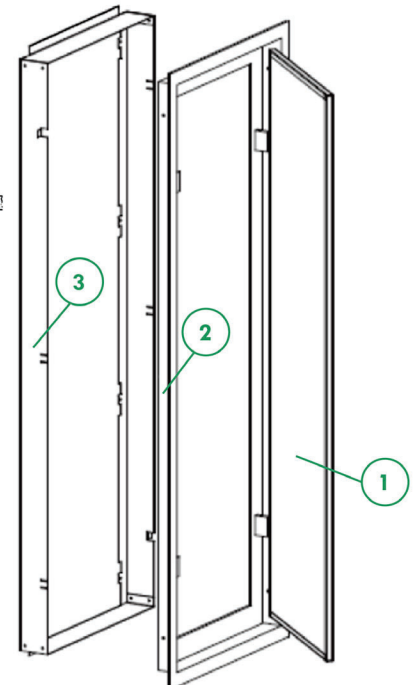
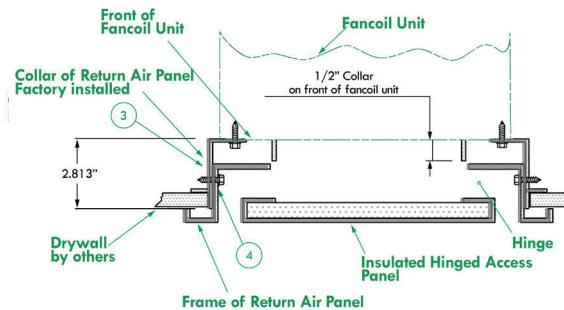

- Hinged insulated access door
- Frame of return air panel
- Collar of return air panel
- Sheet metal screws by installing contractor



Single Supply Air Outlet

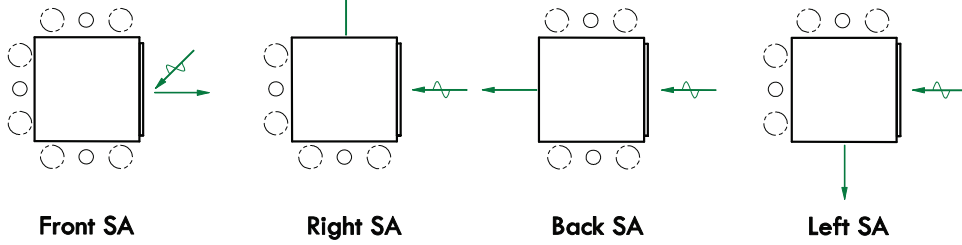

NOTE: Risers can be located on one of the available sides of the unit, where there is not a supply air outlet or return air inlet. 2 pipe riser configuration shown 4 pipe riser configuration also available

2 Sided Supply Air Outlets

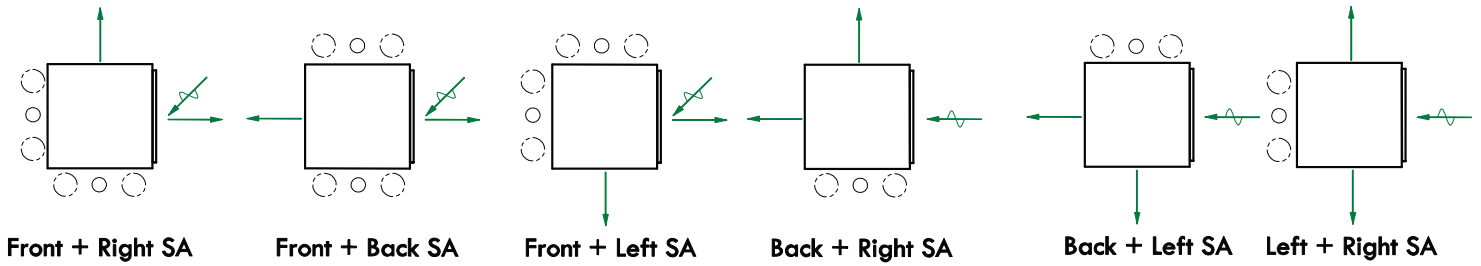

3 Sided Supply Air Outlets

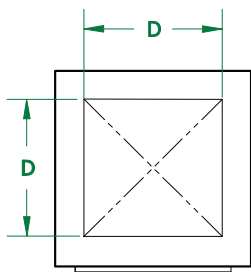
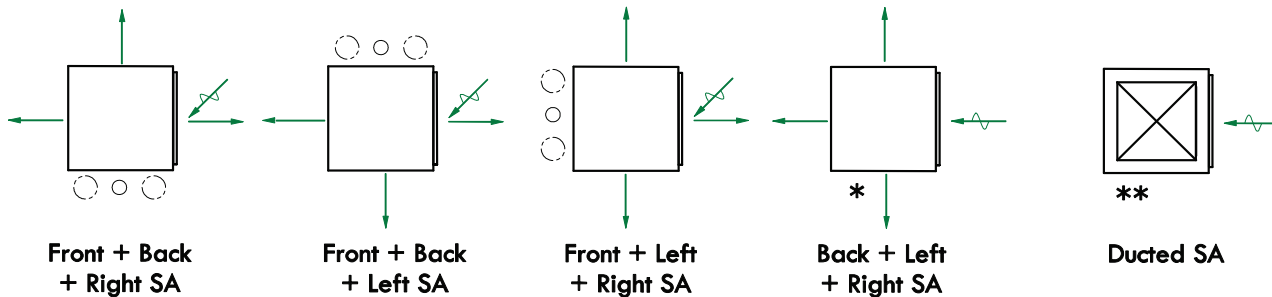

TOP VIEW

* Supply air configuration can only be used with top-capped risers or units that are not connected to risers

**Ducted configuration can be used in combination with any of the other configurations shown.

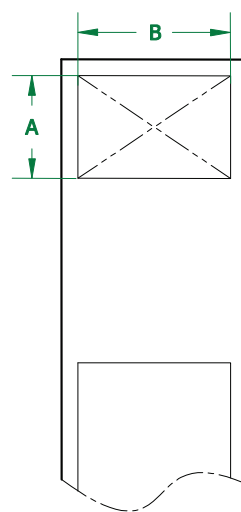

FRONT VIEW

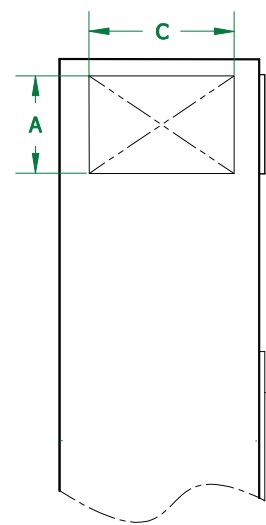

SIDE VIEW

Supply Air Openings

The dimension of unit mounted SA openings vary based on unit size, and number of openings
 To balance the air out of multiple openings, the height of each reduces as additional openings are included
 When there are multiple openings, the grilles included are provided with a volume damper, making them a register
 The width of the opening is paired with the width of the RA opening, to keep them architecturally in line for a clean installation

TL Series - Concealed Units							
TL Series - Opening Sizes for Non-Ducted Units				TL Series : Grilles and registers are steel*, double deflection, and are held in tension to the SA opening via spring clips	TL Series - 100% Ducted SA		
Model	Single (any one side)	Double (any two sides)	Triple (any three sides)		Model	Top Knock-Out	
0300	12" x 12"	12" x 6"	12" x 6"	*upgrade to Aluminum available	0300	10" x 10"	
0400	12" x 12"	12" x 6"	12" x 6"		0400	12" x 12"	
0600	14" x 12"	14" x 8"	14" x 5"		0600	14" x 14"	
0800	14" x 14"	14" x 8"	14" x 8"		0800	14" x 14"	
1000	16" x 14" (front/back) 14" x 14" (left/right)	16" x 10" (front/back) 14" x 10" (left/right)	16" x 8" (front/back) 14" x 8" (left/right)		1000	16" x 16"	
1200	16" x 14" (front/back) 14" x 14" (left/right)	16" x 12" (front/back) 14" x 12" (left/right)	16" x 10" (front/back) 14" x 10" (left/right)		1200	16" x 16"	
	One grille provided	One grille and one register provided	One grille and two registers provided			No grilles or registers provided	
TL Series - Opening Sizes for Combined Unit Mounted Grilles and Ducted Units							
Model	One on unit + Duct off top		Two on unit + Duct off top		Three on unit + duct off top		
	Register	Duct Connection	Register		Duct Connection	Register	Duct Connection
0300	12" x 6"	10" x 10"	12" x 6"	10" x 10"	12" x 6"	10" x 10"	
0400	12" x 6"	10" x 10"	12" x 6"	10" x 10"	12" x 6"	10" x 10"	
0600	14" x 8"	12" x 12"	14" x 5"	10" x 10"	14" x 5"	10" x 10"	
0800	14" x 10"	12" x 12"	14" x 8"	12" x 12"	14" x 5"	10" x 10"	
1000	16" x 10" (front/back) 14" x 10" (left/right)	14" x 14"	16" x 8" (front/back) 14" x 8" (left/right)	12" x 12"	16" x 5" (front/back) 14" x 5" (left/right)	12" x 12"	
1200	16" x 12" (front/back) 14" x 12" (left/right)	14" x 14"	16" x 10" (front/back) 14" x 10" (left/right)	12" x 12"	16" x 8" (front/back) 14" x 8" (left/right)	12" x 12"	
	One register provided		Two registers provided		Three registers provided		

TL Series - SA grilles/registers are all shipped loose for installation after the units are installed, drywall is applied and walls are painted.

TF Series - Finished Cabinet/Exposed Units							
TF Series - Opening Sizes for Non-Ducted Units				TF- Series : Grilles and registers are steel*, double deflection, and are have screws on the short (vertical) side	TF Series - 100% Ducted SA		
Model	Single (any one side)	Double (any two sides)	Triple (any three sides)		Model	Top Knock-Out	
0300	14" x 8"	14" x 5"	14" x 5"	*upgrade to Aluminum available	0300	10" x 10"	
0400	14" x 10"	14" x 5"	14" x 5"		0400	12" x 12"	
0600	16" x 12" (front/back) 14" x 12" (left/right)	16" x 8" (front/back) 14" x 8" (left/right)	16" x 5" (front/back) 14" x 5" (left/right)		0600	14" x 14"	
0800	16" x 14" (front/back) 14" x 14" (left/right)	16" x 8" (front/back) 14" x 8" (left/right)	16" x 8" (front/back) 14" x 8" (left/right)		0800	14" x 14"	
1000	16" x 14" (front/back) 14" x 14" (left/right)	16" x 10" (front/back) 14" x 10" (left/right)	16" x 8" (front/back) 14" x 8" (left/right)		1000	16" x 16"	
1200	16" x 14" (front/back) 14" x 14" (left/right)	16" x 12" (front/back) 14" x 12" (left/right)	16" x 10" (front/back) 14" x 10" (left/right)		1200	16" x 16"	
	One grille provided	One grille and one register provided	One grille and two registers provided			No grilles or Registers provided	
TF Series - Opening Sizes for Combined Unit Mounted Grilles and Ducted Units							
Model	One on unit + Duct off top		Two on unit + Duct off top		Three on unit + duct off top		
	Register	Duct Connection	Register		Duct Connection	Register	Duct Connection
0300	14" x 5"	10" x 10"	14" x 5"	10" x 10"	14" x 5"	10" x 10"	
0400	14" x 8"	10" x 10"	14" x 5"	10" x 10"	14" x 5"	10" x 10"	
0600	16" x 8" (front/back) 14" x 8" (left/right)	12" x 12"	16" x 5" (front/back) 14" x 5" (left/right)	10" x 10"	16" x 5" (front/back) 14" x 5" (left/right)	10" x 10"	
0800	16" x 10" (front/back) 14" x 10" (left/right)	12" x 12"	16" x 8" (front/back) 14" x 8" (left/right)	12" x 12"	16" x 5" (front/back) 14" x 5" (left/right)	10" x 10"	
1000	16" x 10" (front/back) 14" x 10" (left/right)	14" x 14"	16" x 8" (front/back) 14" x 8" (left/right)	12" x 12"	16" x 5" (front/back) 14" x 5" (left/right)	12" x 12"	
1200	16" x 12" (front/back) 14" x 12" (left/right)	14" x 14"	16" x 10" (front/back) 14" x 10" (left/right)	12" x 12"	16" x 8" (front/back) 14" x 8" (left/right)	12" x 12"	
	One register provided		Two registers provided		Three registers provided		

TF Series - SA grilles/registers are all shipped installed, with the same finish as the cabinet

Risers are where the “vertical stack” really comes into play. Temspec can provide risers from the factory, either installed on the cabinets, or shipped loose. It is more common in recent years for risers to ship loose for installation ahead of the units, but the occasional project still ships with risers attached.

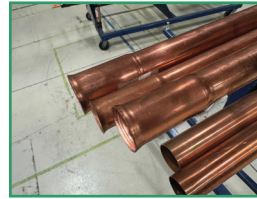

Swagged end of Risers



T-drill/brazed tee w/isolation valve



Insulated risers tested to 300 psi



Crate of loose risers 4' W x 10' L x up to 7' T

- L or M copper
- Risers are tested to 300 psi in our factory with a glycol mixture
- 3/4" pipe size thru 3" pipe size
- Insulated with a variety of materials and thickness'
- Risers can be provided with a swaged end on the top for insertion of the riser pipe from above, or plain ended for field provided and installed fittings
- Risers can be produced up to 10' (120") long, if the floor-to-floor height exceeds 10', a spool piece can be provided to fill this gap. For example, if the floor-to-floor height were 12', a 9' risers is provided with a 3' (+4" for insertion) spool piece
- Stub-outs are T-drill and brazed into the risers, with the isolation valves installed at the factory. Stub-outs are 1/2" pipe for most units with flow rates less than 5.0 gpm. This allows for all of the components in the piping package to fit properly, remain operable, and not choke-out the airflow in the cabinet
- 3/4" stub-outs are provided for flow rates greater than 5.0 gpm, typically for units in the 1,000 and 1,200 cfm range

When considering the riser insulation thickness, be advised that the stub-outs from the risers need to reach inside the cabinet and be operable. In 4 pipe units, with 2" or larger risers, carrying 1" or thicker insulation, a modified "W" pattern will be required for the risers so that they will fit. This pattern will offset the return risers, farther from the cabinet, and require longer stub-outs. This assumes that the supply and condensate riser remain flush to, or closer to the cabinet.

As risers are often shipped loose, it is important to understand where the risers sit relative to the unit cabinet when not installed flush but several inches away, especially for those in a primary/secondary pair. The critical dimension to provide to Temspec is the distance from the centerline of the riser to the edge of the cabinet. With this dimension, the stub-outs can be provided the proper length to reach the cabinet, and have

the isolation valves installed correctly. Once the unit is installed to the risers, the isolation valve needs to sit just inside the cabinet, poking through the insulation that covers the pipe connection opening. The valve handle needs to be operable, at the correct depth into the cabinet to make a 90 degree hose connection from coil to stub-out. It is also important to center the stub-out in those openings, so they are free to expand and contract, without touching the steel edge of the opening.

Riser support, anchoring, and expansion compensation should be field supplied and installed. While loops or in-line compensators have been used in the past, Temspec recommends a floating system that does not add failure points to the components in the riser piping.

A 4 Pipe demo unit that illustrates the risers installed flush to the cabinet, the isolation valves installed to the proper depth, and the correct bend on the stainless steel braided hoses as they connect the risers to the coil

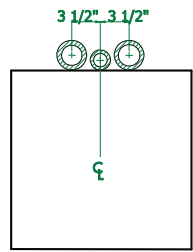

S = Supply Riser
 R = Return Riser
 C = Condensate Riser

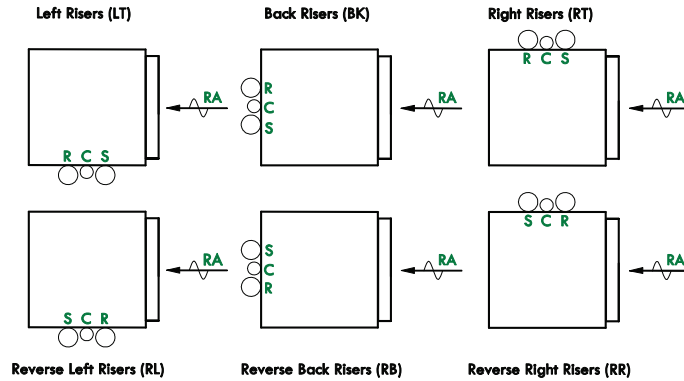

Reverse Left Risers (RL) Reverse Back Risers (RB) Reverse Right Risers (RR)

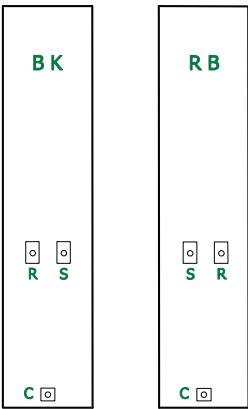

View on Back

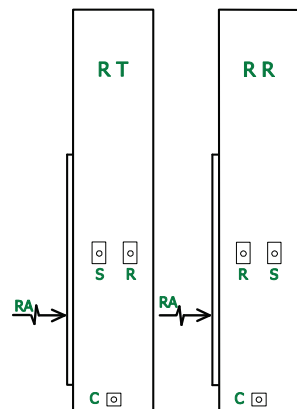

View on Right Side

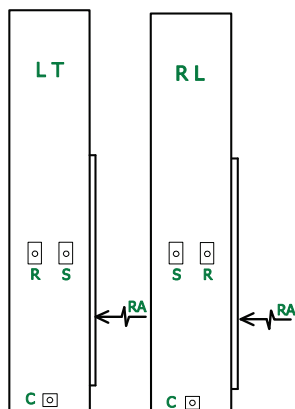

View on Left Side

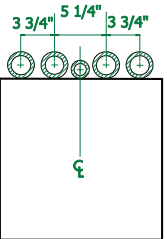
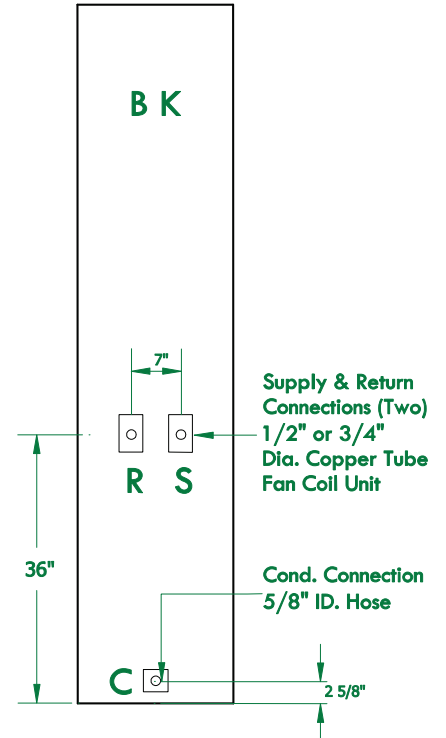

HWS = Hot Water Supply Riser
 HWR = Hot Water Return Riser
 CWS = Chilled Water Supply Riser
 CWR = Chilled Water Return Riser
 Cond. = Condensate Riser

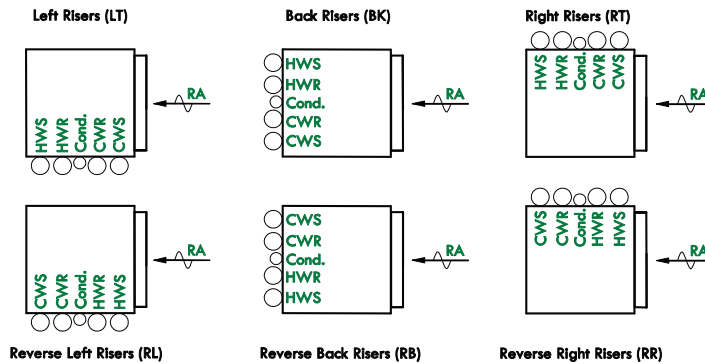

Reverse Left Risers (RL) Reverse Back Risers (RB) Reverse Right Risers (RR)

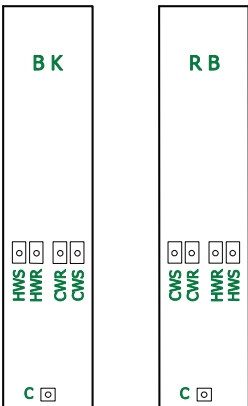

View on Back

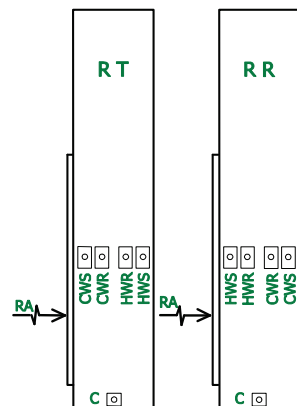

View on Right Side

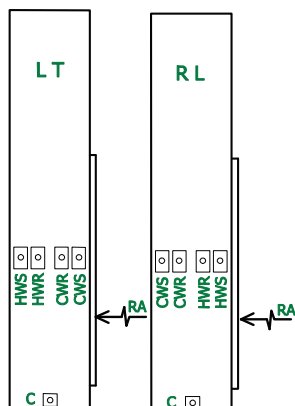

View on Left Side

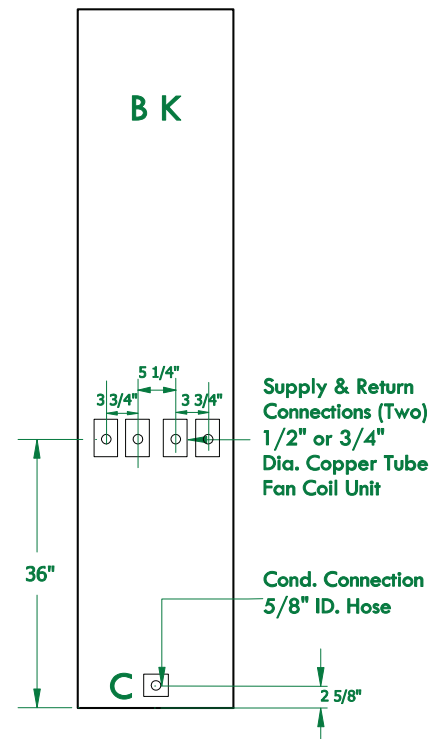

Standard Installation Floor to Floor height less than 120"

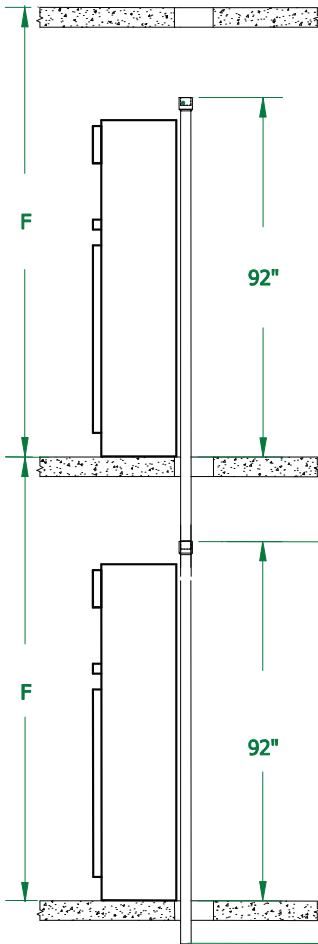

Risers are always sized based on the floor to floor height to ensure the proper assembly. To ensure proper alignment, the top of the riser should always be positioned at a distance of 92" from the finished floor.

This distance allows all the risers to be properly sized based on the length of the riser $L = F + 2"$, where the extra 2" allows for the riser to protrude to the floor below for connection

In the cases where floor to floor height is greater than 120" a spool piece is required to complete the riser installation

L = Length of the Riser
 F = Floor to Floor height

$$L = F + 2$$

$$\text{Spool Piece} = F - L + 4$$

* Centering the stub-out is important to allow the riser space to expand and contract without touching the cabinet.

Installation Using Spool Pieces Floor to Floor height greater than 120"

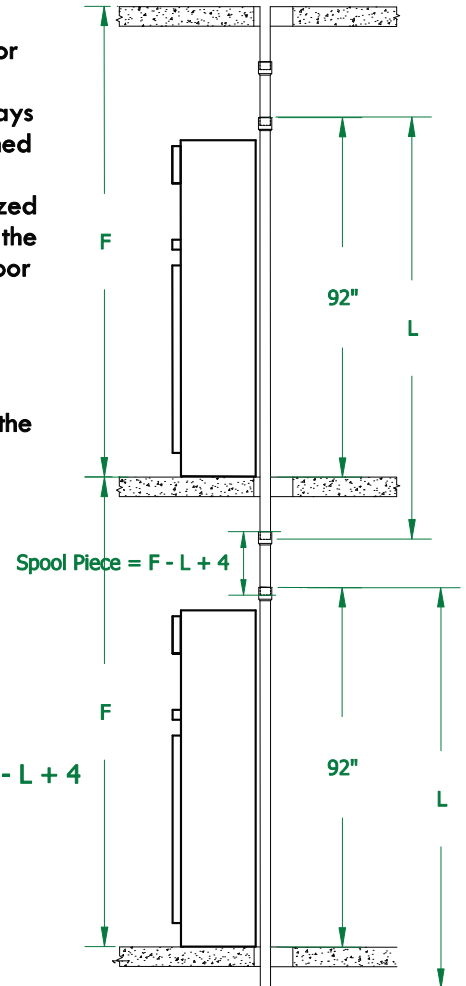

$$\text{Spool Piece} = F - L + 4$$

$$\text{Spool Piece} = F - L + 4$$

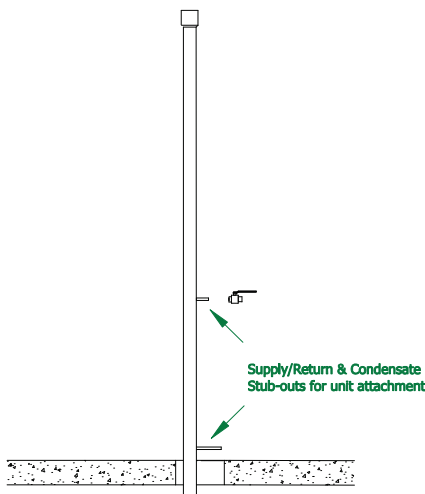

1. Install loose isolation valve and solder onto the stub out. Insure that the stub-out is at correct height off the floor so that it will be centered in the unit opening*.

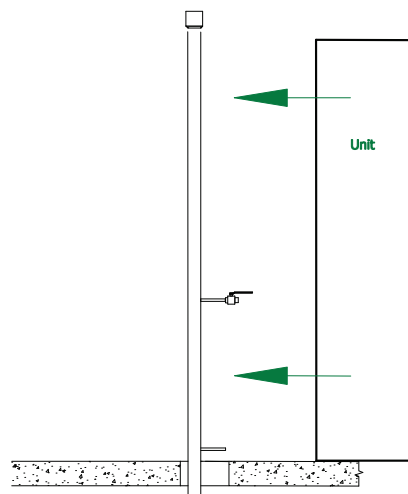

2. Slide the unit into place over top of ball valve so that it penetrates into the cabinet to the correct depth (see above).

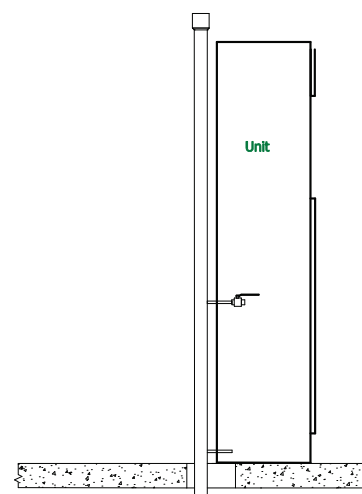

3. Make union connection from hose to ball valve inside the unit. The dimension from outer surface of the unit to union is critical to maintain the proper bend radius of SS hoses and avoid kinking
4. Make the condensate connection with the hose clamp provided

Fan Coil Weights

Weights are approximate
Risers, external accessories, and weight of water in the coil(s) not included

Model	TI Series Concealed Cabinet	TM Series Mechanical Closet Cabinet	TF Series Exposed Finished Cabinet	TR Series Concealed Cabinet w/Recovery Module
0300	130 lbs	120 lbs	140 lbs	215 lbs
0400	140 lbs	125 lbs	145 lbs	225 lbs
0600	170 lbs	155 lbs	180 lbs	230 lbs
0800	180 lbs	160 lbs	185 lbs	235 lbs
1000	210 lbs	190 lbs	220 lbs	270 lbs
1200	220 lbs	200 lbs	230 lbs	280 lbs

Filters

Filters provided are pleated 1" thickness MERV10 - MERV13 available
It is recommended to change your filters each season (every 3 months)

Notes on Filters

For the standard hinged/louvered RA/access panel, the filters mount in a channel behind the louvered portion.

For the perimeter type RA panel, TF series units, and TM series units installed in a mechanical closet, the filter mounted in a channel flange on the front of the unit.

Custom mounting on the face of the coil can be provided for ducted RA variations of the TM series, or units with secondary RA or OA intakes on side or back of the cabinet.

Model	TL & TM Series Concealed and Mechanical Closet Applications	TF Series Exposed Finished Cabinet Applications	TR Series Concealed Cabinet w/Recovery Module
0300	12" x 20" x 1"	14" x 20" x 1"	14" x 25" x 1"
0400	12" x 20" x 1"	14" x 20" x 1"	14" x 25" x 1"
0600	14" x 25" x 1"	16" x 25" x 1"	14" x 25" x 1"
0800	14" x 25" x 1"	16" x 25" x 1"	14" x 25" x 1"
1000	18" x 25" x 1"	16" x 25" x 1"	18" x 25" x 1"
1200	18" x 25" x 1"	16" x 25" x 1"	18" x 25" x 1"

It is important to make sure that air does not bypass the filter to the coil, or you can see dust and dirt build up on the coil, which will reduce efficiency, and can lead to a clogged drain pan.



RA Access Panels - Dimensional Information

Dimensions for the flange or collars and panels installed on the front of the unit
Drywall is either applied directly to the face of the unit (Hinged/Louvered Panel) around the collar, or framed out with studs

Model	Hinged/Louvered RA Panel - TL and TM Series		Perimeter RA Panel - TL and TM Series (TR Series)	
	Flange Dimensions Nominal (actual)	Outer Installed Dimensions	Collar Dimensions TL and TM Series (TR Series)	Outer Installed Dimensions TL and TM Series (TR Series)
0300	12" x 52" (11.877" x 51.797")	14.178" x 54"	18.5" x 53.75" (20.3" x 80.75")	20.75" x 56.25" (22.25" x 83.25")
0400	12" x 52" (11.877" x 51.797")	14.178" x 54"	18.5" x 53.75" (20.3" x 80.75")	20.75" x 56.25" (22.25" x 83.25")
0600	14" x 52" (13.940" x 51.753")	16.241" x 54"	18.5" x 53.75" (20.3" x 80.75")	20.75" x 56.25" (22.25" x 83.25")
0800	14" x 52" (13.940" x 51.753")	16.241" x 54"	18.5" x 53.75" (20.3" x 80.75")	20.75" x 56.25" (22.25" x 83.25")
1000	18" x 54" (18.491" x 53.750")	20.741" x 56.142"	23.125" x 55.75" (24.3" x 80.75")	25.375" x 58.25" (26.25" x 83.25")
1200	18" x 54" (18.491" x 53.750")	20.741" x 56.142"	23.125" x 55.75" (24.3" x 80.75")	23.375" x 58.25" (26.25" x 83.25")

There is a 6" "toe-kick" at the bottom of our fan coil units, from the floor to the bottom of the collar on the front of the unit. Once drywall is applied, and the RA panel installed, the RA panel overlaps that "toe-kick" by slightly more than 1". So a baseboard of 4 1/2" can be cleared without the RA panel cutting into it. If a taller base board is to be installed, consider adding a raised base (2" or more) to elevate the unit above the base board for a cleaner installation.

TL Series – Concealed type vertical stack fan coil units, hidden behind drywall – 86" tall

TM Series – Mechanical closet application vertical stack fan coil units, 100% ducted SA – 70" tall

TF Series – Exposed type vertical stack fan coil units with fully painted cabinets – 86" tall

TR Series - Concealed type vertical stack fan coil units, complete with HRV/ERV recovery module - 86" tall

Certifications

Performance: Unit performance is certified by AHRI in accordance with ANSI/AHRI 440-2024: Performance Rating of Room Fan-Coils

Safety: All standard units are agency listed in the USA and Canada and comply with the requirements of the current editions of UL 60335-2-40/C22.2 No. 60335-2-40

Construction

For concealed and closet applications, (TL, TR and TM units) the cabinets shall be fabricated from 20 gauge steel. For Exposed applications (TF units) the cabinets shall be fabricated from 18 gauge powder coat steel in one of our standard cabinet colors (Off-White, Light Grey, or Beige) or a custom color at an additional cost.

The cabinets shall be lined with 1-inch fiberglass insulation bonded with a thermosetting resin or grip nails and coated on the airstream side with an acrylic facing. Optional upgrade to 1/2 -inch closed cell cabinet insulation, which has the same thermal efficiency as 1-inch fiberglass. TR series units are only available with 1/2" closed cell cabinet insulation.

The drain pan shall be polymer (size and 300 thru 800 in the TL and TM series only) or acrylic (black polyester powder) coated 20 gauge galvanized steel. All drain pans are positively sloped in two directions towards the outlet. Metal drain pans shall be insulated on the underside with the same material as the cabinet. The reinforced drain hose from the outlet to the condensate riser shall form a running trap. An optional stainless steel drain pan is also available for all series and unit sizes. A drain pan float switch shall be included, the float switch will close CW control valve upon detection of high-water level in condensate drain pan.

Fan

Backward inclined impeller fan with integrated electronically commutated motor (ECM). Fan must have an over-all minimum efficiency of 58%. Forward curved fans cannot be accepted.

Motors

The fan motor shall be an electronically commutated, EC brushless, type with sealed bearings. All motors have a maximum ambient operating temperature of 140°F and are permanently lubricated. The motor can accept a 0-10VDC signal configured to deliver the specified airflow with no special tools. A three-speed controller board is available allowing the fan to be compatible with a conventional 3 speed thermostat. PSC motors cannot be accepted. Fan wattage listed in schedule must not be exceeded.

The combination of the EC motor operated at 0-10VDC and a 2 position control valve can be excellent for dehumidification. The algorithm that most 0-10 fan control capable thermostats will operate on will start the fan at a minimum cfm (typically 50% of nominal) and maintain this cfm up to 66% of operating time, only ramping up to max (nominal) cfm when far off set point (less than 10% of operating time). With the minimum airflow across the coil, and the CW valve full open, the humidity will be drawn out of the air, as it condenses on the coil. The air velocity will be so low that drafts will not be felt on the skin, the unit will be very quiet, and using less energy.

Disconnect

An unfused service disconnect switch shall be included, mounted inside the unit behind the motor cover. A fused disconnect is available, typically for primary electric heat units with higher MCA.

Coils

The coil shall have 0.0045" ± 0.0005" aluminum fins mechanically bonded to 1/2-inch diameter with minimum 0.015" tube wall copper tube. The coil shall be factory pressure tested at no less than 300 psig. A manual air vent shall be incorporated at the high point of the connecting pipework to the coil.

Piping Packages

The piping package shall include: Ball type shut-off valves on the coil supply and returns (combined with balancing valves or strainers when used), and a two- or three-way control valve with two-position actuator. Chilled water valves are typically normally closed (NC) and hot water valves are typically normally open (NO).



Control valves are also available in 3 wire floating point or 2-10 VDC modulating valves. 2-position or modulating 6-way valves are available for low grade heating water applications. Additionally, balancing valves (manual or automatic) and strainers supplied as riser system dictates. These devices are provided as combo-valves with the shut-off on supply and return and can be equipped with PT ports as required. Combo valves are used to keep them accessible, for maintenance, and limit the number of mechanical or solder connections in the piping package.

Electrical Heat

Units with electric heat shall have single power connection and be wired for single-stage operation with an open wire nickel-chrome element. An auto-reset high limit device shall be included. SSR “quiet” relays available, as well as SCR for modulating control.

Filters

A one-inch MERV. 10 disposable filter shall be shipped loose with return air access panel (ships installed on TF exposed units). Units equipped with one inch MERV 10 filters have a rating based on ASHRAE Standard 52.2. The average dust spot efficiency is no less than 35 to 40 percent when tested in accordance with ASHRAE 52.1 atmospheric dust spot method. Upgrade to MERV13 available.

Controls - Thermostat

The fan coil manufacturer shall supply a low voltage (24V) digital programmable thermostat with remote sensor and energy savings contacts option for remote mounting, or unit mounted. The thermostat has a PI 0-10VDC fan output control and 2 binary outputs for 2 position NO or NC valve control. Remote mounted thermostats are connected to a terminal strip that is provided inside the unit. The thermostat is shipped loose for installation after the unit is installed, drywall is applied, and the walls are painted. Alternate thermostat options include: analog valve control valve outputs, 3 speed fan control, PIR occupancy sensor, and BACNet compatible. TR units have an internal control board to control defrost and freeze protection mode, external 24V signal required to run and enter boost mode.

Riser Package

Risers from 3/4” to 3” are available in both type “L” and type “M” copper for supply, return and condensate pipes. Riser insulation is available in 1/2-inch to 1” wall thickness for closed cell foam (polyolefin), closed cell elastomeric (similar to Armaflex®) and fiberglass (wrapped with vapor barrier). Insulation thickness shall comply with ASHRAE 90.1. Riser diameter and insulation thickness are subject to physical limitations. Contact Temspc on 4-pipe risers larger than 2.0 inches in diameter. The risers shall have an approximately 3” swaged expansion at the top end to allow a 2” insertion of the riser from above without the use of couplings. Risers may be provided plain ended in lieu of swaged for field supplied/installed fittings (similar to Pro-Press®). The riser insulation shall have a flame spread rating of 25 or less and a smoke developed rating of 50 or less in compliance with ASTM E 84. The insulation shall be continuous over the riser length within the height of the cabinet. Provision for insulation beyond the ends of the cabinet shall be the responsibility of the installing contractor. The specification of riser anchoring, expansion loops and fire stopping requirements are not detailed in this specification and are not part of the Temspc fan coil scope.

Return Air Access Panel

The return air access panel shall have a fixed blade return air grille in the lower portion with hinged panel filter access. The return air panel installs flush on to the drywall which has been applied directly to the front of the unit. The panel is of stamped steel construction and shall be finished in standard white baked enamel. The panel secured to the unit by a hook on the bottom edge and sheet metal fasteners to the cabinet. The panel is shipped loose for installation after the unit is installed, drywall is applied, and the walls are painted. There are optional perimeter type “bladeless”, and full face panel designed to cover the entire opening for retrofit applications available in sizes from 86” – 94” high x 18” - 26” wide.

For TF exposed units, the return air access panel shall have a fixed blade return air grille in the lower portion with quick release screws in the upper corners to remove the panel and access the filter. Panel is of stamped steel construction and shall have the same finish as the cabinet. The return air panel is integral to the cabinet and is shipped installed.

A perimeter type, return air access panel shall be a full height hinged door type for concealed TR series fan coil units. The return air panel installs flush on to the drywall the drywall is away from the unit for after framing around collar. The panel is steel construction and shall be finished in standard white baked enamel. The panel secured to the unit by sheet metal fasteners to the collar. The panel is shipped loose for installation after the unit is installed, dry wall is applied, and the walls are painted.

Supply Air Grilles and Registers

Supply air grilles and registers shall be provided for unit mounting locations. The grilles shall be steel, have double deflection airfoil blades and shall be finished in standard white baked enamel (or same finish as the cabinet if provided for a TF exposed units). The grilles shall attach to the collar of the fan coil unit by spring clips. (Screws on the vertical side for TF exposed units) When a unit has more than one supply air opening a balancing damper (horizontal in the front) is included with the grille (register) to balance the air flow (screw holes optional). Any supply air grilles which are part of supply air ductwork shall be provided by the sheet metal contractor. Grilles are shipped loose for installation after the unit is installed, drywall applied, and the walls are painted. (Grilles are shipped installed on TF exposed units) A line-of-sight baffle with acoustical wrap shall be included in units which have left and right or front and back supply air openings. There is also an option to upgrade the supply air grille material to aluminum as well as the option to provide custom colors for return air panels and supply air grilles/registers. TR series units are ducted only.

Raised Bases

Raised bases are available in heights of 4", 8", or 12" (or custom heights as required). An access panel is available for bases 8" or taller. If a condensate pump is required, a minimum 8" high raised base with front access panel is provided. Condensate pump is wired to and powered by the fan coil unit.

Fresh Air/Outside Air (OA) Intakes

The unit can be equipped with a fresh air/OA intake. Whether the OA is coming directly from outside, or a pre-treated DOAS, the opening is located in the space below the drain pan. The opening is 6" x 4" (or 4"D round) and can be on the left, right or back. When on the left and/or right, it is towards the front of the cabinet (~1" off the front face). When on the back, it will be located to the side opposite the riser/pipe connection (ie: Riser are on the right of the unit, the OA intake would be towards the left side on the back). When the air comes from a DOAS, a manual sliding damper and filter is provided.

When the air comes directly from outside, a motorized (2 position) damper is provided that is interlocked with the SA fan (only open if the SA fan is running). For cold climates, or if desired, a low limit temperature sensor can also be included. Mounted between the intake and the coil. If the air temp drops to 45F or below, the damper will close, the valve will open, and the fan will run to achieve active heat transfer to prevent freezing. The damper will remain in that state until the air temp rises above 55F.

TF Exposed Units – Additional Sheetmetal Accessories

When units are not concealed behind drywall, fully exposed with a painted cabinet, additional sheetmetal accessories are included to complete the installation in the finished space. These include:

Top Extensions to fill the gap from the top of the unit to the ceiling. Top extensions can be two (type EL or ER) or three sided (type EC or EU), their height should include an additional 1 1/2" to overlap the top of the fan coil unit. They are powder coated steel, the same finish as the fan coil unit cabinet.

Side Pipe Covers/Block-Off Panels to conceal the riser/pipe connections to the unit. They can be one (type PL), two (type PJ) or three (type PC) sided depending where the pipe connections are located on the fan coil unit cabinet and relative to any walls. They are provided the same height as the cabinet (86") and are typically 6" wide to accommodate any risers, though this dimension can be ordered to suit your installation. They are powder coated steel, the same finish as the fan coil unit cabinet.

ERV/HRV Module - for TR Series

ERV shall be an AHRI certified counterflow design with a minimum 70% sensible recovery and 60% total recovery at 60CFM using polymer membrane washable core that blocks VOC's, CO₂, and other gases & contaminants. HRV core shall be an AHRI certified counterflow design under standard 1060 and provide minimum 80% sensible recovery using a polymer washable core.

Fresh air and space exhaust air shall be filtered using minimum MERV 8 washable filter. Energy recovery module shall incorporate two fans with independent variable speed control for system balancing. Fans to be backward inclined type with variable speed ECM capable of supplying 100CFM at 0.5" WC in boost mode activated by a pushbutton timer switch. Forward curved fans and PSC motors will not be accepted. E/HRV shall be equipped with freeze protection and operate down to -4F (-20C). Exhaust only defrost is standard. Electric preheat is an alternative.

CONTACT OUR TEAM TODAY



The Temspec Team

- 54 years of experience in Vertical Stack Fan Coils
- Sales, Engineering, R&D, & Production under one roof
- Support from the design thru to commissioning
- Engineering and service support to the field
- Expertise in sound analysis, riser systems & controls



Design Recommendations

- BI Fan with integral ECM (0-10 vDC) for a VAV control strategy
- Dehumidification by running the fan at minimum speed, and opening the CW valve (avoid reheat)
- 2 position control valves (simple valve control for low gpm)
- Hinged RA access panel - no exposed fasteners, easy filter changing without the use of tools
- 1" glass-fiber insulation - best thermal and acoustical performance
- Polymer drain pans - will not sweat or corrode (300-800cfm units only)
- Don't oversize the units - right size unit for the right size space
- Properly sized risers - should decrease in size as they move away from the mains, carrying less water



326 Superior Blvd - Mississauga, ON L5T 2N7
www.temspec.com - sales@temspec.com
905-670-3595
1-888-836-7732